

#7 (.201) DRILL - THRU  
 1/4-20 TAP - THRU  
 1 REQUIRED  
 (USE PAD PROVIDED)

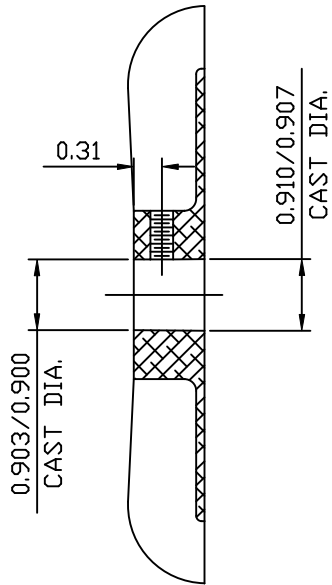
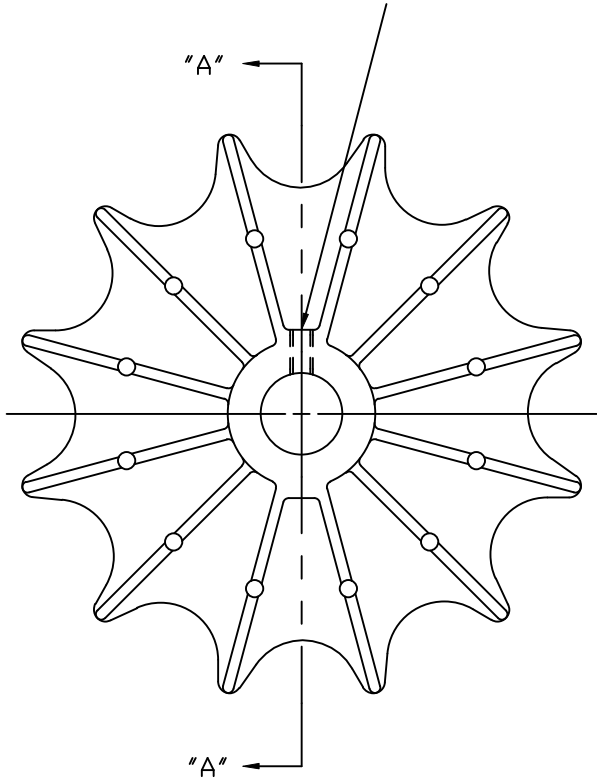

SECTION "A-A"

CASTING NO. 003530-01

				TOLERANCES UNLESS OTHERWISE SPECIFIED		<b>LEESON</b> ELECTRIC CORPORATION		
				DECIMALS				
				.00	± .01	DRAWN DLL 1/3/78	TITLE EXTERNAL FAN MACHINING	
				.000	± .005	CH'K'D. RPB 1/13/78	56 FRAME	
1	REDRAWN	PG	9/8/88	.0000	± .0005	APPR. JCW 1/13/78	MAT'L. #380 ALUMINUM ALLOY	
NO.	REVISION	BY	DATE	FRACTIONS	± 1/64	SCALE HALF	(DIE CAST)	
THIS DRAWING IN DESIGN AND DETAIL IS OUR PROPERTY AND MUST NOT BE USED EXCEPT IN CONNECTION WITH OUR WORK ALL RIGHTS OF DESIGN AND INVENTION ARE RESERVED				ANGLES	± 1/2°	REF. 022003-01	FINISH	
				INCH/MM		FMF 6K17FB8B	SUKUP	
							SIZE A	DRAWING NO. 022023-01

ERROR: syntaxerror  
OFFENDING COMMAND: --nostringval--

STACK:

/im  
-savelevel-