

# **BALDOR® • RELIANCE**

**Product Information Packet**

**ELECTRIC MOTOR WHOLESAL.COM**

**ASM7510**

**10HP,3450RPM,3PH,60HZ,7535M,TEFC,F1**

Part Detail									
Revision:	R	Status:	PRD/A	Change #:		Proprietary:	No		
Type:	AC	Prod. Type:	7535M	Elec. Spec:	07WG5029	CD Diagram:			
Enclosure:	TEFC	Mfg Plant:		Mech. Spec:	7-2000	Layout:			
Frame:		Mounting:	F1	Poles:	02	Created Date:			
Base:	RG	Rotation:	R	Insulation:	B	Eff. Date:	09-06-2011		
Leads:	9#14	Literature:		Elec. Diagram:		Replaced By:			
Nameplate NP1264L									
CAT.NO.	ASM7510								
SPEC.	7-2000-5029								
HP	10 SAW DUTY								
VOLTS	230/460								
AMP	24/12								
RPM	3450								
FRAME		HZ	60			PH	3		
SER.F.	1.00	CODE	F			DES	B	CL	B
NEMA-NOM-EFF		PF							
RATING	40C AMB-CONT								
CC		USABLE AT 208V	26						
DE	5211	ODE	6206						
ENCL	TEFC	SN							

Parts List		
Part Number	Description	Quantity
SA080466	SA 7-2000-5029	1.000 EA
RA073867	RA 7-2000-5029	1.000 EA
28CB1000A01	CONDUIT BOX MACH	1.000 EA
30GS1002	GASKET, CONDUIT BOX	1.000 EA
10XN2520A16	1/4-20 X 1 HEX HEAD CAP SCR, ZINC PLATED	2.000 EA
HW1003A25	WASHER, 1/4 EX TH LK, ZN X	2.000 EA
10XN2520A12	O1/4-20X 3/4 HEX HEAD CAP	2.000 EA
HW1003A25	WASHER, 1/4 EX TH LK, ZN X	2.000 EA
11XW1032G06	10-32 X .38, TAPTITE II, HEX WSHR SLTD U	1.000 EA
HW3001B01	003SS CUP WASHER, FOR #8 SCREW	1.000 EA
07EP1107A01	FR ENDPLATE, MACH	1.000 EA
HW4500A20	1/8NPT SL PIPE PLUG	1.000 EA
84XN3118J44	5/16-18UNC X 2.75 LG. SOC HD CAP SCR,BLK	4.000 EA
HW1001A31	LOCKWASHER 5/16, ZINC PLT.591 OD, .319 I	4.000 EA
HW5100A06	W2420-025 WVY WSHR (WB)	1.000 EA
07EP1104A03	PU ENDPLATE, MACH	1.000 EA
HW4500A20	1/8NPT SL PIPE PLUG	1.000 EA
84XN2520J32	SCREW, 1/4-20 X 2", SHC, AS	4.000 EA
HW1001A25	LOCKWASHER 1/4, ZINC PLT .493 OD, .255 I	4.000 EA
84XN3118J40	5/16-18UNC X 2.50 LG. SOC HD CAP SCR,BLK	4.000 EA
HW1003A31	WASHER,5/16 EX TH LK, ZN X	4.000 EA
35FN2000A07SP	EXFN, ALUM, 5.75 OD, 1.182 ID	1.000 EA
80XN2520A06	1/4-20 X 3/8 SET SCREW	1.000 EA
37FH4500A03SP	FAN COVER, AUTOPHERETIC PRIMER	1.000 EA

Parts List (continued)		
Part Number	Description	Quantity
51XN1032A06	10-32 X .38 HEX SLOTTED SERRATED WASHER	4.000 EA
28CB1500A01	CONDUIT BOX LID MACH	1.000 EA
30GS1005	GASKET, CONDUIT BOX LID	1.000 EA
84XN2520J12	1/4-20 X 3/4 SOC.HD CAP SCR	2.000 EA
HW1001A25	LOCKWASHER 1/4, ZINC PLT .493 OD, .255 I	2.000 EA
HW2500A21	KEY, USA #807, WOODRUFF	1.000 EA
WD4100A13	PLUG, N.P.#277 (NIAGARA)	1.000 EA
85XU0407A04	#4-7 X 1/4 DRIVE PIN	2.000 EA
MJ1000A75	GREASE, POLYREX EM EXXON	0.050 LB
MG1000G27	PAINT- S9282E CHARCOAL GREY	0.021 GA
LB1125C01	STD (STOCK) CARTON LABEL BALDOR WITH FLA	1.000 EA
LC0005E01	CONN.DIA./WARNING LABEL (LC0005/LB1119)	1.000 EA
LB5040	INSTRUCTION TAG, AC & DC	1.000 EA
NP1264L	STD NP ALUM, W/O THERMAL W/O CSA OR UL	1.000 EA
37PA1052	PACKAGING GROUP, 150 LB MTR 2 X 4 RUNNER	1.000 EA
PK3085	STYROFOAM SHAFT SUPPORT ZELLERBACH	1.000 EA
PK3082	STYROFOAM CRADLE	1.000 EA

Performance Data at 460V, 60Hz, 10.0HP (Typical performance - Not guaranteed values)							
General Characteristics							
Full Load Torque:	15.0 LB-FT			Start Configuration:	DOL		
No-Load Current:	2.4 Amps			Break-Down Torque:	54.0 LB-FT		
Line-line Res. @ 25°C.:	1.45 Ohms A Ph / 0.0 Ohms B Ph			Pull-Up Torque:	29.0 LB-FT		
Temp. Rise @ Rated Load:				Locked-Rotor Torque:	44.0 LB-FT		
Temp. Rise @ S.F. Load:				Starting Current:	93.0 Amps		
Load Characteristics							
% of Rated Load	25	50	75	100	125	150	S.F.
Power Factor:	79.0	89.0	92.0	96.0	96.0	98.0	0.0
Efficiency:	70.0	80.9	83.3	83.4	84.0	81.9	0.0
Speed:	3575.0	3550.0	3524.0	3500.0	3470.0	3436.0	0.0
Line Amperes:	4.3	6.6	9.3	11.7	14.5	17.2	0.0

Performance Graph at 460V, 60Hz, 10.0HP Typical performance - Not guaranteed values

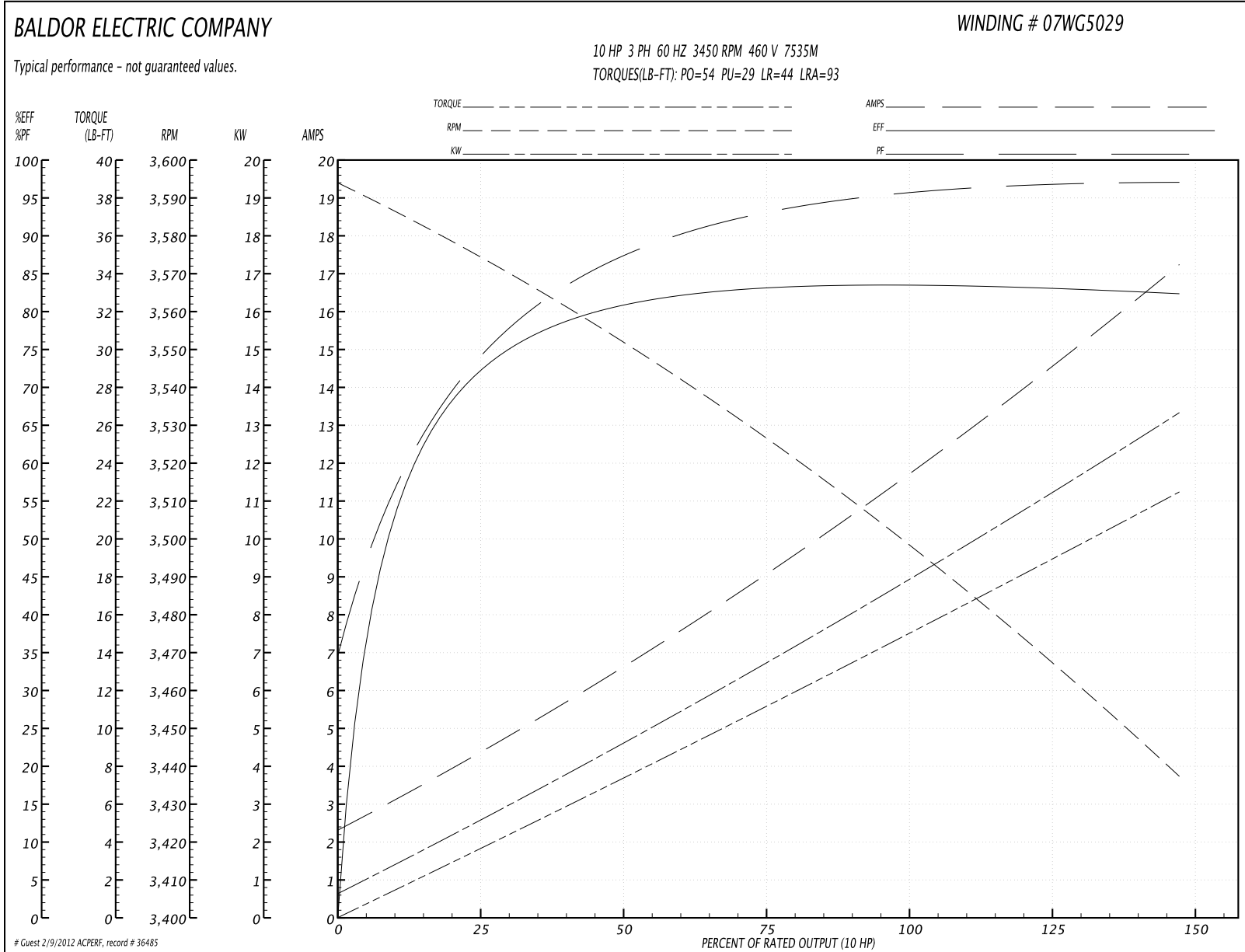

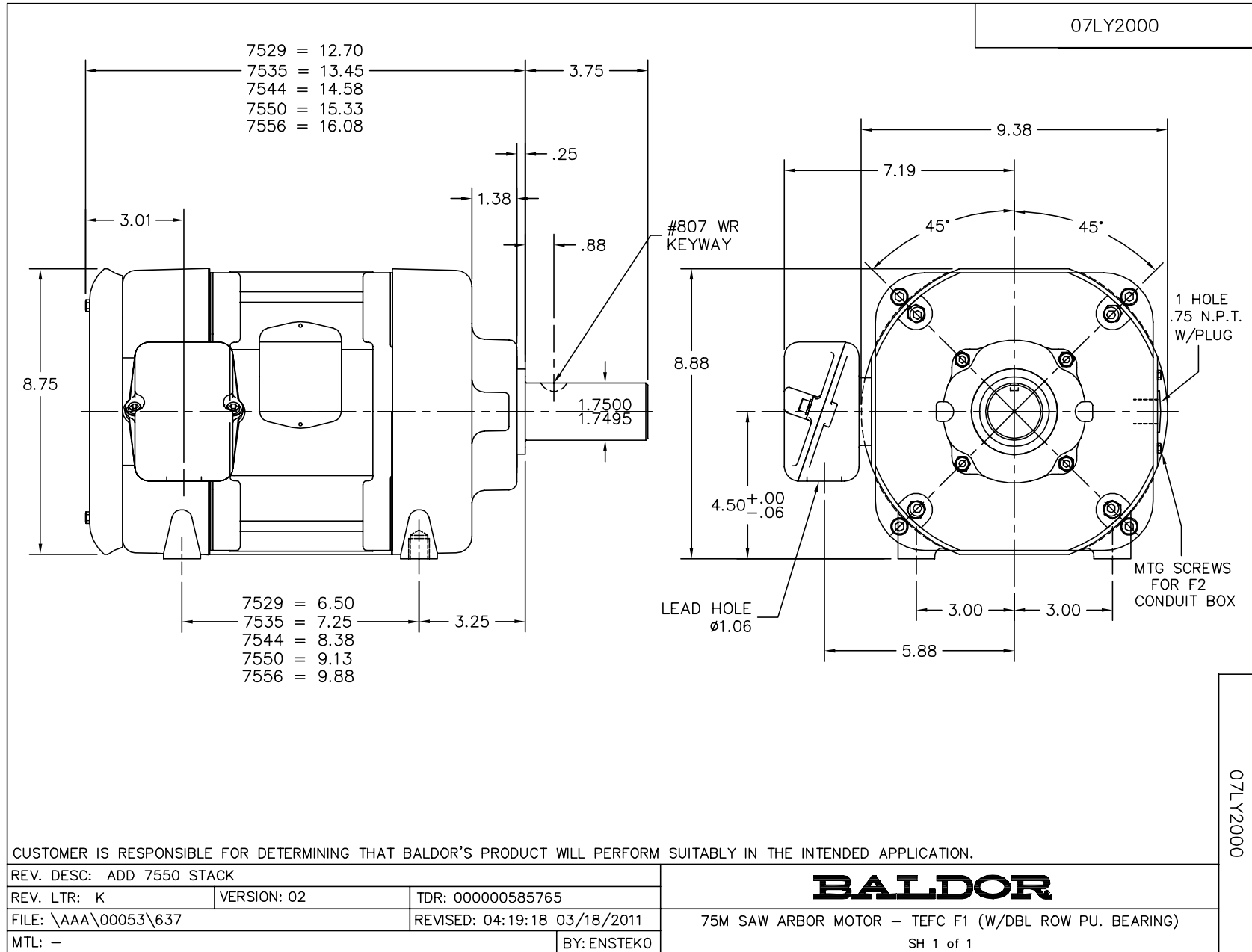

CD0005



LOW VOLTAGE  
(2Y)



LINE

HIGH VOLTAGE  
(1Y)



LINE

NOTES:

1. INTERCHANGE ANY TWO LINE LEADS TO REVERSE ROTATION.
2. OPTIONAL THERMOSTATS ARE PROVIDED WHEN SPECIFIED.
3. ACTUAL NUMBER OF INTERNAL PARALLEL CIRCUITS MAY BE A MULTIPLE OF THOSE SHOWN ABOVE.
4. LEAD COLORS ARE OPTIONAL. LEADS MUST ALWAYS BE NUMBERED AS SHOWN.

REV. DESC: REVISE TO SHOW OPTIONAL COLORS			
REV. LTR: E	BY: JLP	REVISED: 01/19/99 10:15	TDR: 0171435
90000		FILE: AAA00005140	MDL: -
		MTL: -	

**BALDOR ELECTRIC Co.**

3PH, DV, 9 LEADS

CD0005