

BALDOR® • ***RELIANCE***

Product Information Packet

ELECTRIC MOTOR WHOLESAL.COM

BM3603

1HP,1740RPM,3PH,60HZ,182,3514M,TEFC,F1,B

Part Detail							
Revision:	G	Status:	PRD/A	Change #:		Proprietary:	No
Type:	AC	Prod. Type:	3514M	Elec. Spec:	35WGP676	CD Diagram:	
Enclosure:	TEFC	Mfg Plant:		Mech. Spec:	35M527	Layout:	
Frame:	182	Mounting:	F1	Poles:	04	Created Date:	02-18-2008
Base:	RG	Rotation:	R	Insulation:	B	Eff. Date:	11-02-2011
Leads:	9#18	Literature:		Elec. Diagram:		Replaced By:	

Nameplate NP1256L

CAT.NO.	BM3603						
SPEC.	35M527P676G1						
HP	1						
VOLTS	208-230/460						
AMP	3.9-3.6/1.8						
RPM	1740						
FRAME	182	HZ	60	PH	3		
SER.F.	1.15	CODE	L	DES	B	CLASS	B
NEMA-NOM-EFF	75.5	PF	67				
RATING	40C AMB-CONT						
CC			USABLE AT 208V				
DE	6205	ODE	6203				
ENCL	TEFC	SN					

Parts List		
Part Number	Description	Quantity
SA168813	SA 35M527P676G1	1.000 EA
RA157106	RA 35M527P676G1	1.000 EA
NS2512A01	INSULATOR, CONDUIT BOX X	1.000 EA
35CB3007	35 CB CASTING W/.88 DIA. LEAD HOLE	1.000 EA
36GS1000SP	GASKET-CONDUIT BOX, .06 THICK #SV-330 LE	1.000 EA
51XB1016A07	10-16 X 7/16 HXWSSLD SERTYB	2.000 EA
11XW1032G06	10-32 X .38, TAPTITE II, HEX WSHR SLTD U	1.000 EA
35EP3900T02	SPL FACE MTD FR EP-ENCL-W/STEARNS BRAKE	1.000 EA
HW4500A01	1641B(ALEMITE)400 UNIV, GREASE FITT	1.000 EA
HW5100A03SP	WAVY WASHER (W1543-017)	1.000 EA
35EP3101A03	STL PU EP-ENCL-205 BRG-W/GREASER&FAN ON	1.000 EA
HW4500A01	1641B(ALEMITE)400 UNIV, GREASE FITT	1.000 EA
XY1032A02	10-32 HEX NUT DIRECTIONAL SERRATION	4.000 EA
HW2501D10	KEY, 3/16 SQ X 1.000	1.000 EA
35FN3002A02SP	EXFN, PLASTIC, 6.376 OD, .987 ID W/KEY	1.000 EA
51XB1214A16	12-14X1.00 HXWSSLD SERTYB	1.000 EA
HW2500A16	EY, USA #606, WOODRUFF	1.000 EA
35FH4005A13	IEC FH W/GRSR & 1.09 SHAFT HOLE, W/ AUTO	1.000 EA
51XW1032A06	10-32 X .38, TAPTITE II, HEX WSHR SLTD S	3.000 EA
35CB4521GX	CONDUIT BOX LID KIT	1.000 EA
51XW0832A07	8-32 X .44, TAPTITE II, HEX WSHR SLTD SE	4.000 EA
HW2501D13SP	KEY, 3/16 SQ X 1.375	1.000 EA
HA7000A01	KEY RETAINER 7/8" DIA SHAFT	1.000 EA
85XU0407S04	4X1/4 U DRIVE PIN STAINLESS	2.000 EA

Parts List (continued)		
Part Number	Description	Quantity
MJ1000A75	GREASE, POLYREX EM EXXON	0.050 LB
84XN3816J28	HEX SOC HD, 3/8-16 X 1.75 LONG	2.000 EA
MG1000G27	PAINT- S9282E CHARCOAL GREY	0.017 GA
HA3100A18	THRUBOLT 10-32 X 9.250	4.000 EA
76BK2100BPF	1-056-021-00-BPF BRAKE TDR# 79345	1.000 EA
LB1125C01	STD (STOCK) CARTON LABEL BALDOR WITH FLA	1.000 EA
LB1185	LABEL,BRAKE CONNECTION (ON ROLLS)	1.000 EA
LC0005E01	CONN.DIA./WARNING LABEL (LC0005/LB1119)	1.000 EA
NP1256L	ALUM, UL CSA CC, W/O THERMAL, LASER	1.000 EA
G7PA1000	PACKAGING GROUP / BALDOR	1.000 EA

Performance Data at 460V, 60Hz, 1.0HP (Typical performance - Not guaranteed values)
General Characteristics

Full Load Torque:	2.99 LB-FT	Start Configuration:	DOL
No-Load Current:	1.48 Amps	Break-Down Torque:	12.8 LB-FT
Line-line Res. @ 25°C.:	20.0 Ohms A Ph / 0.0 Ohms B Ph	Pull-Up Torque:	8.38 LB-FT
Temp. Rise @ Rated Load:	61 C	Locked-Rotor Torque:	9.9 LB-FT
Temp. Rise @ S.F. Load:	69 C	Starting Current:	12.0 Amps

Load Characteristics

% of Rated Load	25	50	75	100	125	150	S.F.
Power Factor:	30.0	45.0	57.0	67.0	75.0	80.0	72.0
Efficiency:	52.3	67.6	73.0	75.7	76.3	75.7	76.1
Speed:	1785.0	1771.0	1756.0	1740.0	1722.0	1702.0	1729.0
Line Amperes:	1.48	1.56	1.67	1.82	2.04	2.29	1.95

Performance Graph at 460V, 60Hz, 1.0HP Typical performance - Not guaranteed values

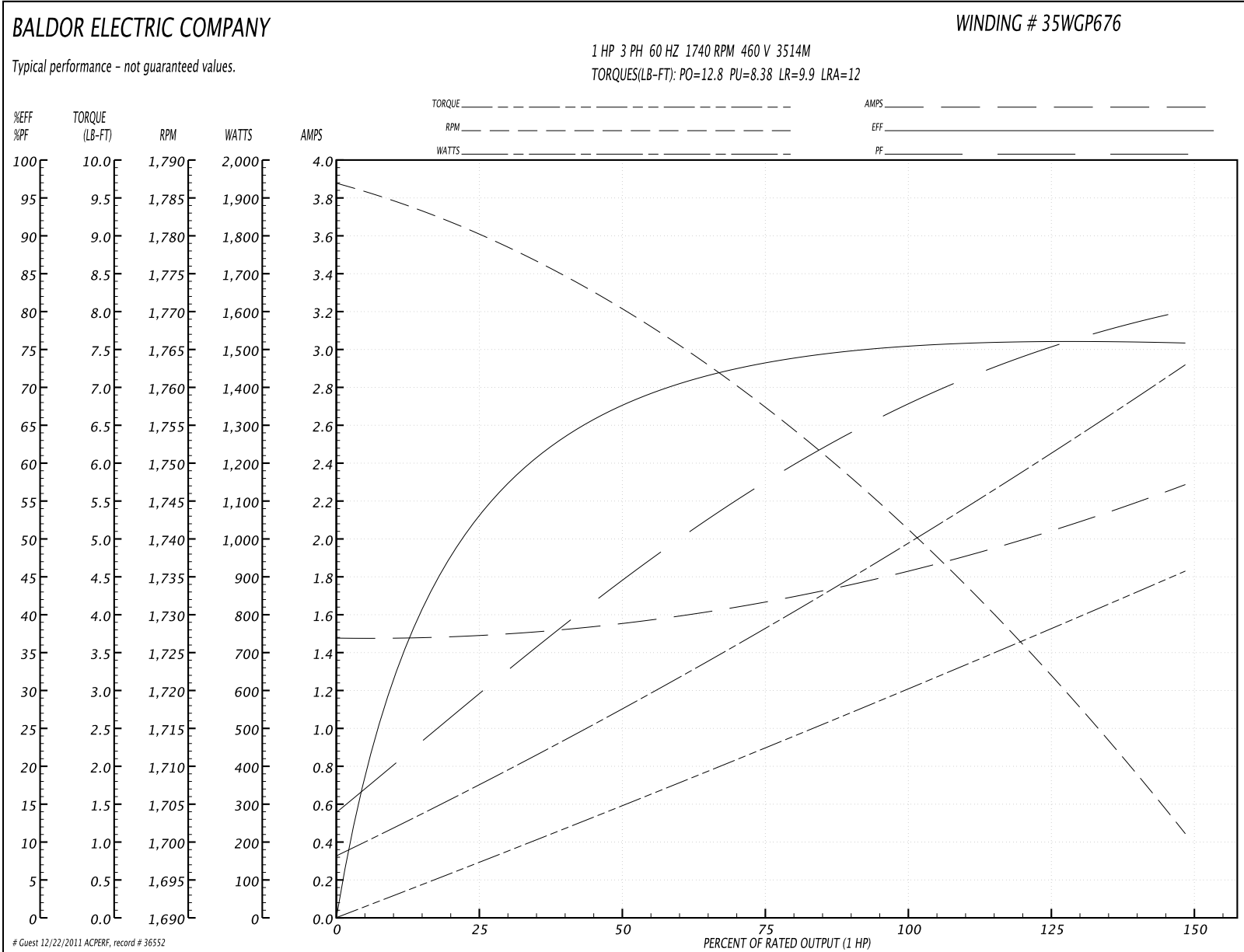

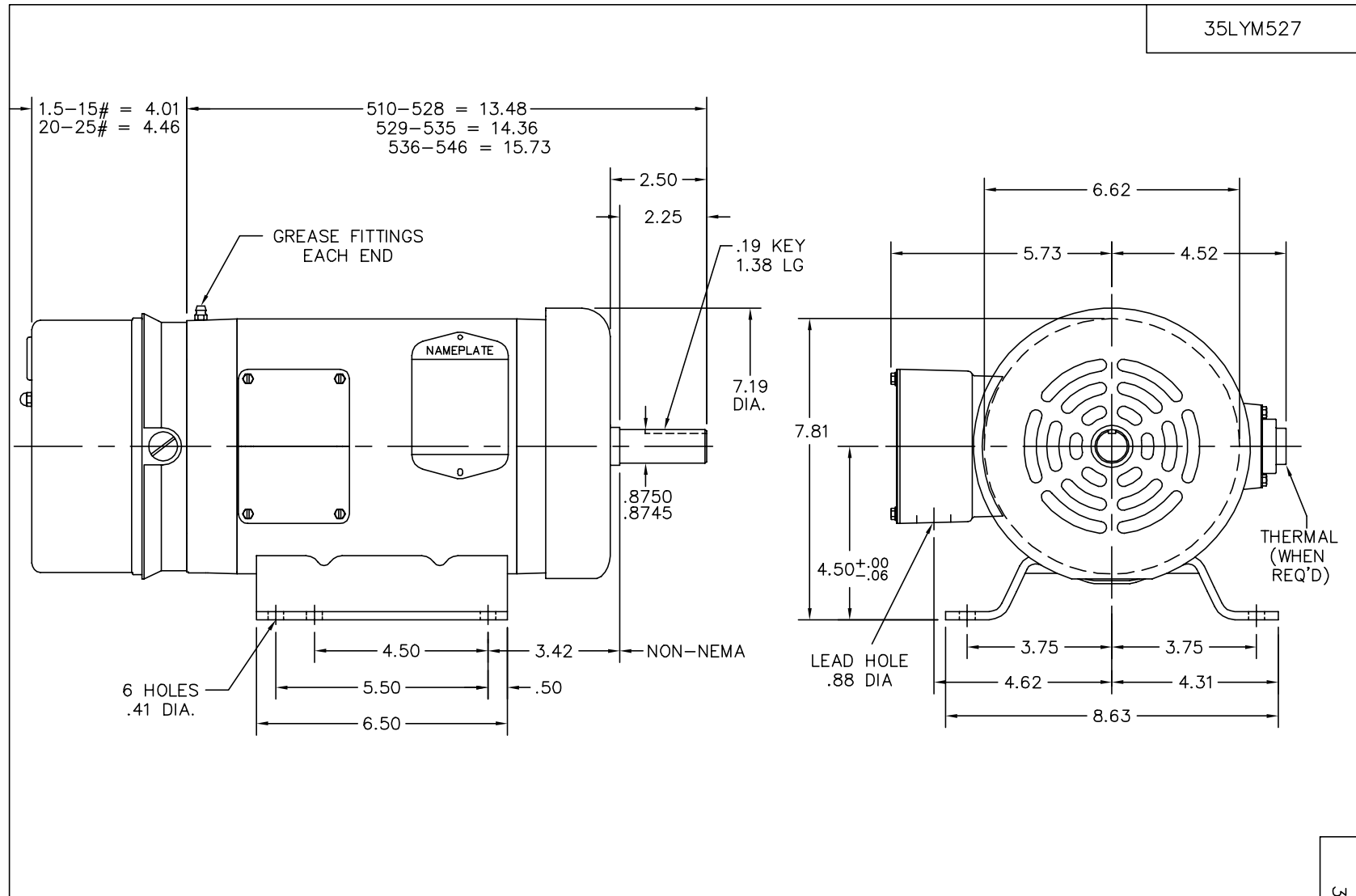

CUSTOMER IS RESPONSIBLE FOR DETERMINING THAT MOTOR PERFORMANCE IS SUITABLE IN THE APPLICATION.

REV. DESC: 35SB0778 WAS 35SB1233

REV. LTR: C BY: RMP REVISED: 13:35:39 05/06/2003 TDR: 301485

FILE: AAA00013693 REF: 35LYM527

MTL: -

BALDOR ELECTRIC Co.

STD HORZ 182-4 TEFC 35M W/BRAKE

35LYM527

CD0005



LOW VOLTAGE
(2Y)

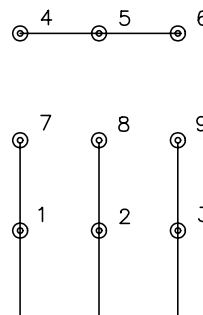

LINE

HIGH VOLTAGE
(1Y)



LINE

NOTES:

1. INTERCHANGE ANY TWO LINE LEADS TO REVERSE ROTATION.
2. OPTIONAL THERMOSTATS ARE PROVIDED WHEN SPECIFIED.
3. ACTUAL NUMBER OF INTERNAL PARALLEL CIRCUITS MAY BE A MULTIPLE OF THOSE SHOWN ABOVE.
4. LEAD COLORS ARE OPTIONAL. LEADS MUST ALWAYS BE NUMBERED AS SHOWN.

REV. DESC: REVISE TO SHOW OPTIONAL COLORS			
REV. LTR: E	BY: JLP	REVISED: 01/19/99 10:15	TDR: 0171435
900000		FILE: AAA00005140	MDL: -
		MTL: -	

BALDOR ELECTRIC Co.

3PH, DV, 9 LEADS

CD0005