

BALDOR® • RELIANCE

Product Information Packet

ELECTRIC MOTOR WHOLESAL.COM

CM3314T

15HP,3450RPM,3PH,60HZ,215TC,3735M,OPSB

Part Detail							
Revision:	S	Status:	INA/A	Change #:		Proprietary:	No
Type:	AC	Prod. Type:	3735M	Elec. Spec:	37WGY510	CD Diagram:	
Enclosure:	OPSB	Mfg Plant:		Mech. Spec:	37B102	Layout:	
Frame:	215TC	Mounting:	F1	Poles:	02	Created Date:	
Base:	RG	Rotation:	R	Insulation:	B	Eff. Date:	05-19-2009
Leads:	9#14	Literature:		Elec. Diagram:		Replaced By:	

Nameplate NP1256L

CAT.NO.	CM3314T						
SPEC.	37B102Y510H1						
HP	15						
VOLTS	208-230/460						
AMP	37-35/17.5						
RPM	3450						
FRAME	215TC	HZ	60	PH	3		
SER.F.	1.15	CODE	H	DES	B	CLASS	B
NEMA-NOM-EFF	89.5	PF	90				
RATING	40C AMB-CONT						
CC	010A	USABLE AT 208V	37				
DE	6307	ODE	6206				
ENCL	OPSB	SN					

Parts List		
Part Number	Description	Quantity
SA030491	SA 37B102Y510H1	1.000 EA
RA026532	RA 37B102Y510H1	1.000 EA
S/P101-000-000	EPACT PROCEDURES-FS PLANT-POLYREX EM, NO	1.000 EA
HA6361A01	LIFTING LUG FOR 37, 39 & 40 FRAME (AUTOP	2.000 EA
37CB3006	37 CB CASTING W/1.38 LEAD HOLE @ 6:00	1.000 EA
51XW2520A10	.25-20 X .62, TAPTITE II, HEX WSHR SLTD	2.000 EA
11XW1032G06	10-32 X .38, TAPTITE II, HEX WSHR SLTD U	1.000 EA
37EP3200A01SP	FR ENDPLATE, 37L&M, OPEN, MACH, W/GREASE	1.000 EA
HW4500A01	1641B(ALEMITE)400 UNIV, GREASE FITT	1.000 EA
HW5100A06	W2420-025 WVY WSHR (WB)	1.000 EA
37EP3400A01	FACE MT EP-OPEN-307 BRG-213-215TC W/GREA	1.000 EA
HW4500A01	1641B(ALEMITE)400 UNIV, GREASE FITT	1.000 EA
10XN2520A30	HEX HD CAP SCREW-STD THD-.25 X 20 THD PE	4.000 EA
HW1001A25	LOCKWASHER 1/4, ZINC PLT .493 OD, .255 I	4.000 EA
XY3118A12	5/16-18 HEX NUT DIRECTIONAL SERRATION	4.000 EA
37CB4516	LIPPED LID FOR 37 FRAME NEC KOBX	1.000 EA
51XW0832A07	8-32 X .44, TAPTITE II, HEX WSHR SLTD SE	4.000 EA
HW2501F21	KEY, 5/16 SQ X 2.375	1.000 EA
HA7000A02	KEY RETAINER RING, 1 1/8 DIA, 1 3/8 DIA	1.000 EA
85XU0407S04	4X1/4 U DRIVE PIN STAINLESS	2.000 EA
LB1115	LABEL,LIFTING DEVICE	1.000 EA
MJ1000A75	GREASE, POLYREX EM EXXON	0.050 LB
MG1000G27	PAINT- S9282E CHARCOAL GREY	0.028 GA
37AD2001A01	BAFFLE PLATE, STAMPED	2.000 EA

Parts List (continued)		
Part Number	Description	Quantity
HA3104A39	THRUBOLT-5/16-18 X 12.250	4.000 EA
LB1125C04	STD-E (STOCK CTN LABEL STD-E WITH FLAG)	1.000 EA
LC0005E01	CONN.DIA./WARNING LABEL (LC0005/LB1119)	1.000 EA
NP1256L	ALUM, UL CSA CC, W/O THERMAL, LASER	1.000 EA
36PA1001	PACKAGING GROUP	1.000 EA

Performance Data at 460V, 60Hz, 15.0HP (Typical performance - Not guaranteed values)
General Characteristics

Full Load Torque:	22.6 LB-FT	Start Configuration:	DOL
No-Load Current:	4.9 Amps	Break-Down Torque:	82.0 LB-FT
Line-line Res. @ 25°C.:	0.755 Ohms A Ph / 0.0 Ohms B Ph	Pull-Up Torque:	32.0 LB-FT
Temp. Rise @ Rated Load:	64 C	Locked-Rotor Torque:	48.0 LB-FT
Temp. Rise @ S.F. Load:	79 C	Starting Current:	124.0 Amps

Load Characteristics

% of Rated Load	25	50	75	100	125	150	S.F.
Power Factor:	64.0	83.0	89.0	91.0	92.0	92.0	92.0
Efficiency:	85.7	89.8	90.2	89.6	88.5	87.0	88.9
Speed:	3572.0	3544.0	3514.0	3482.0	3447.0	3408.0	3461.0
Line Amperes:	6.4	9.5	13.1	17.2	21.6	26.3	19.8

Performance Graph at 460V, 60Hz, 15.0HP Typical performance - Not guaranteed values

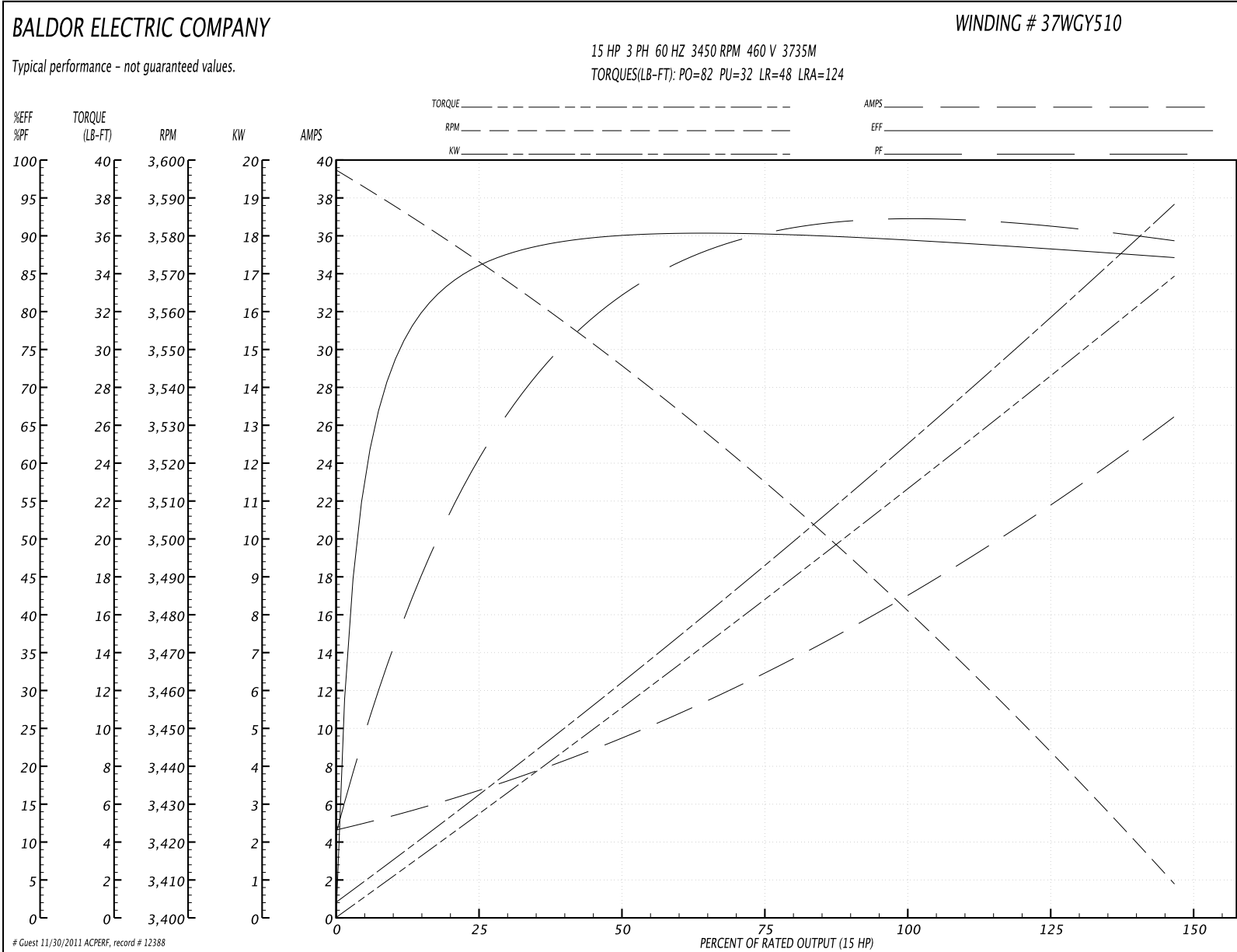

37LYB102

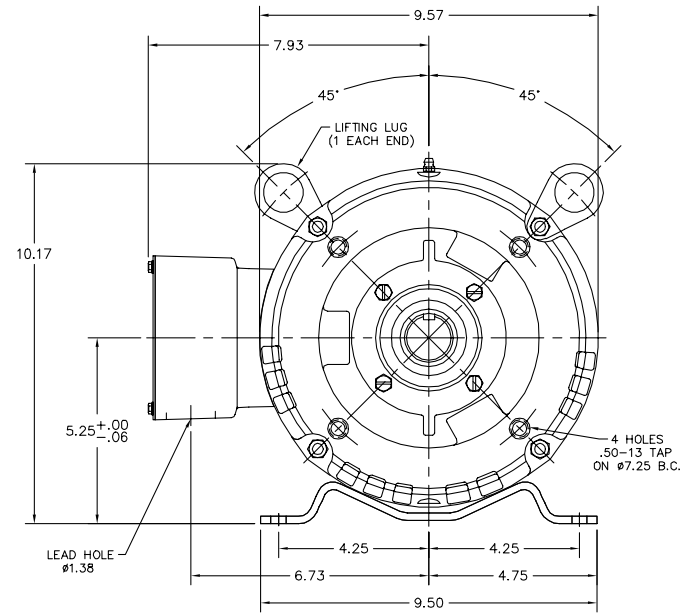
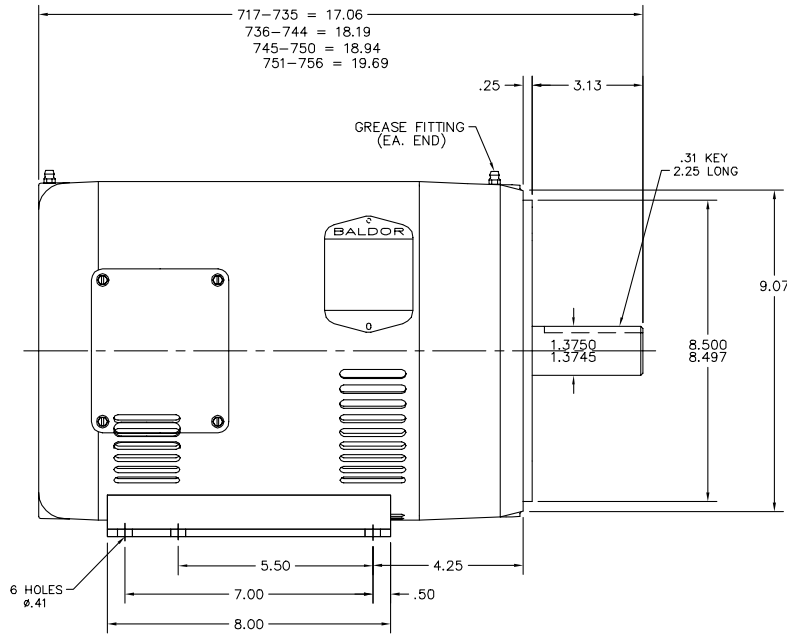

37LYB102

CUSTOMER IS RESPONSIBLE FOR DETERMINING THAT BALDOR'S PRODUCT WILL PERFORM SUITABLY IN THE INTENDED APPLICATION.

REV. DESC: CORRECTED LIFTING LUG GRAPHICS	VERSION: 01	TDR: 000000487051
REV. LTR: E	REVISED: 08:23:39 01/09/2009	BY: ENSTES0
FILE: \AAA\00045\872		
MTL: -		

BALDOR • DODGE • RELIANCE

STD HORZ 213-5TC OPSB 37M

SH 1 of 1

CD0005



LOW VOLTAGE
(2Y)

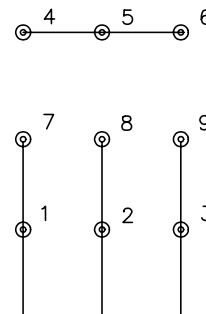

LINE

HIGH VOLTAGE
(1Y)



LINE

NOTES:

1. INTERCHANGE ANY TWO LINE LEADS TO REVERSE ROTATION.
2. OPTIONAL THERMOSTATS ARE PROVIDED WHEN SPECIFIED.
3. ACTUAL NUMBER OF INTERNAL PARALLEL CIRCUITS MAY BE A MULTIPLE OF THOSE SHOWN ABOVE.
4. LEAD COLORS ARE OPTIONAL. LEADS MUST ALWAYS BE NUMBERED AS SHOWN.

REV. DESC: REVISE TO SHOW OPTIONAL COLORS			
REV. LTR: E	BY: JLP	REVISED: 01/19/99 10:15	TDR: 0171435
900000		FILE: AAA00005140	MDL: -
		MTL: -	

BALDOR ELECTRIC Co.

3PH, DV, 9 LEADS

CD0005