

# **BALDOR® • RELIANCE**

**Product Information Packet**

**ELECTRIC MOTOR WHOLESAL.COM**

**EBM4103T**

**25HP,1770RPM,3PH,60HZ,284T,BRAKE,1046M**

Part Detail							
Revision:	L	Status:	PRD/A	Change #:		Proprietary:	No
Type:	AC	Prod. Type:	1046M	Elec. Spec:	10WGX209	CD Diagram:	
Enclosure:	TEFC	Mfg Plant:		Mech. Spec:	10F574	Layout:	
Frame:	284T	Mounting:	F1	Poles:	04	Created Date:	
Base:	RG	Rotation:	R	Insulation:	F	Eff. Date:	09-26-2011
Leads:	9#10	Literature:		Elec. Diagram:		Replaced By:	

Nameplate NP2138L							
CAT.NO.	EBM4103T	P/N		ENCLOSURE	TEFC		
SPEC.	10F574X209G1	CC	010A	FRAME	284T	S/N	
HP	25	CLASS	F	HZ	60		
RPM	1770	PH	3	DES	B		
VOLT	230/460	KVA-CODE	G	ODE BRG	6309	DE BRG	6311
AMP	60/30	USABLE AT 208V	63.3				
RATING	40C AMB-CONT	GREASE	POLYREX EM				
NEMA-NOM-EFF	93.6	PF	84	SER.F.	1.15		
HTR-VOLTS		HTR-AMPS		MAX. SPACE HEATER TEMP.			

Parts List		
Part Number	Description	Quantity
SA116526	SA 10F574X209G1	1.000 EA
RA107485	RA 10F574X209G1	1.000 EA
S/P107-000-004	SUPER-E(284 FR. & UP)-CL PLANT,POLYREX E	1.000 EA
10CB3000SP	STD KO BOX MODEL 310,312,314 MTRS W/2.00	1.000 EA
12GS1000SP	GASKET	1.000 EA
10XN3118K12	5/16-18 X .75 GRADE 5, ZINC PLATED	4.000 EA
HW1001A31	LOCKWASHER 5/16, ZINC PLT.591 OD, .319 I	4.000 EA
WD1000B16	KPA-4C BURNDY TERMINAL	1.000 EA
51XF2520A08	SCREW, HEX SER SLT HD, ZN 1/4-20 X .50 L	1.000 EA
10EP1902A01	ENDPLATE/FAN COVER MACH	1.000 EA
HA4051A00	PLASTIC CAP FOR GREASE FITTING	1.000 EA
HA4001A01SP	DRAIN PLUG, PLASTIC (MICRO PLAS)	1.000 EA
84XN3816A106	3/8 - 16 X 6.62 LONG SOC.HD.CAP SC.	4.000 EA
HW1001A38	LOCKWASHER 3/8, ZINC PLT .688 OD, .382 I	4.000 EA
HW5100A11	W3917-042 WVY WSHR (WB)	1.000 EA
HA7149A01	C-FACE ADPT MACH FOR 10EP1902 ENDPLATES	1.000 EA
10XN5013K28	1/2-13 X 1.75 HEX HEAD MACH SCREW,GRAD	4.000 EA
HW1001A50	LOCKWASHER 1/2, ZINC PLT,.879 OD, .509 I	4.000 EA
15194-75	PIPE PLUG 3/4-14 TAPERED THREAD, ZINC PL	1.000 EA
10XN2520K32	1/4-20 X 2.00 HX HD SCRW GRADE 5, ZINC P	2.000 EA
HW1001A25	LOCKWASHER 1/4, ZINC PLT .493 OD, .255 I	2.000 EA
10XN3118K40	5/16-18 X 2.50" HEX HD, GRADE 5	4.000 EA
HW1001A31	LOCKWASHER 5/16, ZINC PLT.591 OD, .319 I	4.000 EA
10EP1105A01	PU ENDPLATE, MACH 284-6T	1.000 EA

Parts List (continued)		
Part Number	Description	Quantity
HA4051A00	PLASTIC CAP FOR GREASE FITTING	1.000 EA
HA4001A01SP	DRAIN PLUG, PLASTIC (MICRO PLAS)	1.000 EA
10XN3816K28	3/8-16 X 1.75 HEX HD CAP SCREW, GRADE 5	4.000 EA
84XN5013L16	1/2-13X1 NYLOK TYP HX SOCHD CAP SCREW TD	4.000 EA
HW2501G16	KEY, 3/8 SQ X 1.750	1.000 EA
10CB3500SP	CONDUIT BOX LID, CAST	1.000 EA
10GS1000SP	GASKET, CONDUIT BOX LID	1.000 EA
51XW2520A12	.25-20 X .75, TAPTITE II, HEX WSHR SLTD	4.000 EA
HA1005A04SP	SLINGER, OD 3.620, ID 1.98,	1.000 EA
HW2501H28	KEY, 1/2 SQ X 3.250	1.000 EA
LB1115	LABEL,LIFTING DEVICE	1.000 EA
HW4500A21	1618BALEMITE FITTING 825 UNIVERSAL	1.000 EA
HA4017A01	1/8 X 4 GREASE EXT (F/S)	1.000 EA
HW4500A17	317400 ALEMITE GREASE RELIEF	1.000 EA
MJ1000A75	GREASE, POLYREX EM EXXON	0.130 LB
HW4500A03	GREASE FITTING, .125 NPT 1610(ALEMITE) 8	1.000 EA
HW4500A17	317400 ALEMITE GREASE RELIEF	1.000 EA
09FN3001C02	EXTERNAL FAN, PLASTIC	1.000 EA
HW2500A25	WOODRUFF KEY USA #1008 #BLOW CARBON STEE	1.000 EA
51XB1214A20	12-14X1.25 HXWSSLD SERTYB	1.000 EA
LB5040	INSTRUCTION TAG, AC & DC	1.000 EA
87BK8111MQF	1-087-081-11-MQF BRAKE	1.000 EA
LB1125C02	SUPER-E (STOCK CTN LABEL SUPER-E WITH FL	4.000 EA
LB1357	ENERGY GUIDE LABEL (BOX LABEL)	2.000 SH

Parts List (continued)		
Part Number	Description	Quantity
MG1000Y03	WILKO 689.710 GOLD PAINT SUPER E	0.070 GA
85XU0407A04	#4-7 X 1/4 DRIVE PIN	4.000 EA
LC0005E02	SPL CONN.DIA./WARN.LABEL(LC0005/LB1119)	1.000 EA
NP2138L	LARGE NP BALDOR SUPER-E LASER BLANK	1.000 EA
10PA1010	PACKAGING GROUP,BRAKE MTRTDR 10086	1.000 EA

**Performance Data at 460V, 60Hz, 25.0HP (Typical performance - Not guaranteed values)**

General Characteristics							
Full Load Torque:	74.2 LB-FT			Start Configuration:	DOL		
No-Load Current:	11.3 Amps			Break-Down Torque:	235.0 LB-FT		
Line-line Res. @ 25°C.:	0.307 Ohms A Ph / 0.0 Ohms B Ph			Pull-Up Torque:	98.1 LB-FT		
Temp. Rise @ Rated Load:	52 C			Locked-Rotor Torque:	123.0 LB-FT		
Temp. Rise @ S.F. Load:	63 C			Starting Current:	186.0 Amps		
Load Characteristics							
% of Rated Load	25	50	75	100	125	150	S.F.
Power Factor:	50.0	73.0	81.0	85.0	86.0	85.0	86.0
Efficiency:	88.7	92.3	93.5	93.6	93.1	92.0	93.3
Speed:	1793.0	1785.0	1779.0	1771.0	1763.0	1755.0	1766.0
Line Amperes:	13.3	17.6	23.3	29.6	36.5	44.2	33.7

Performance Graph at 460V, 60Hz, 25.0HP Typical performance - Not guaranteed values

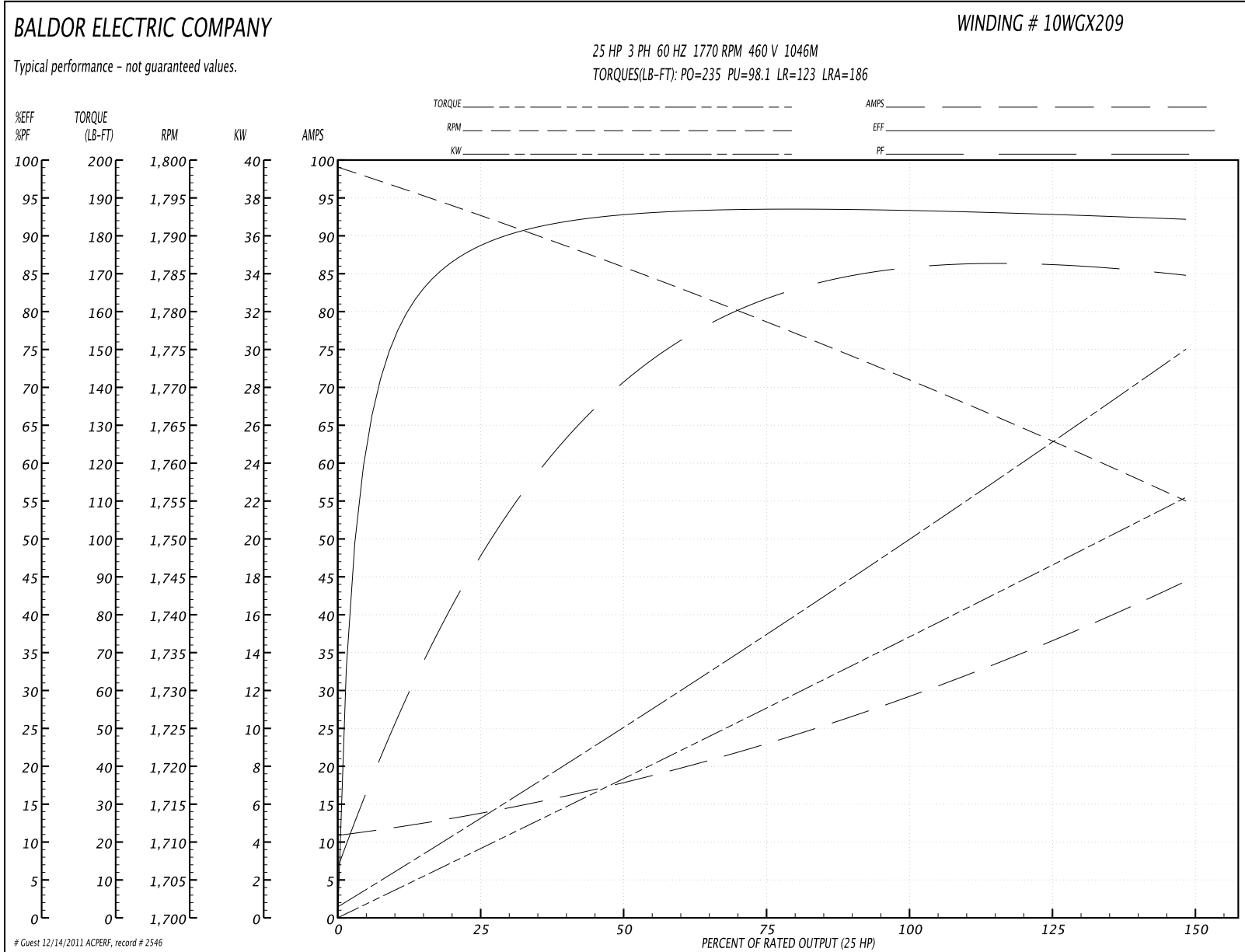

10LYF574

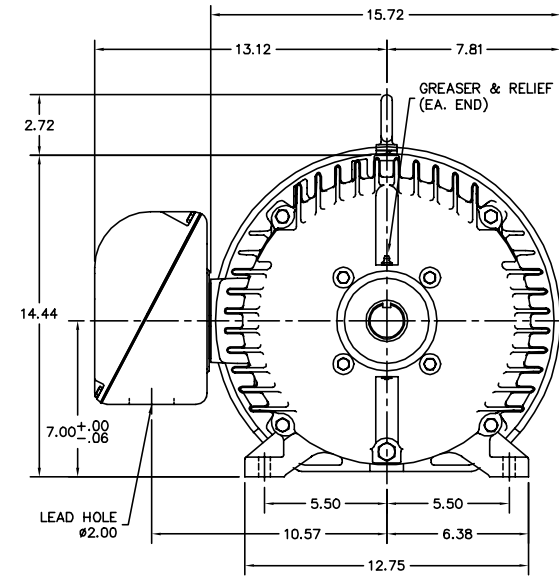
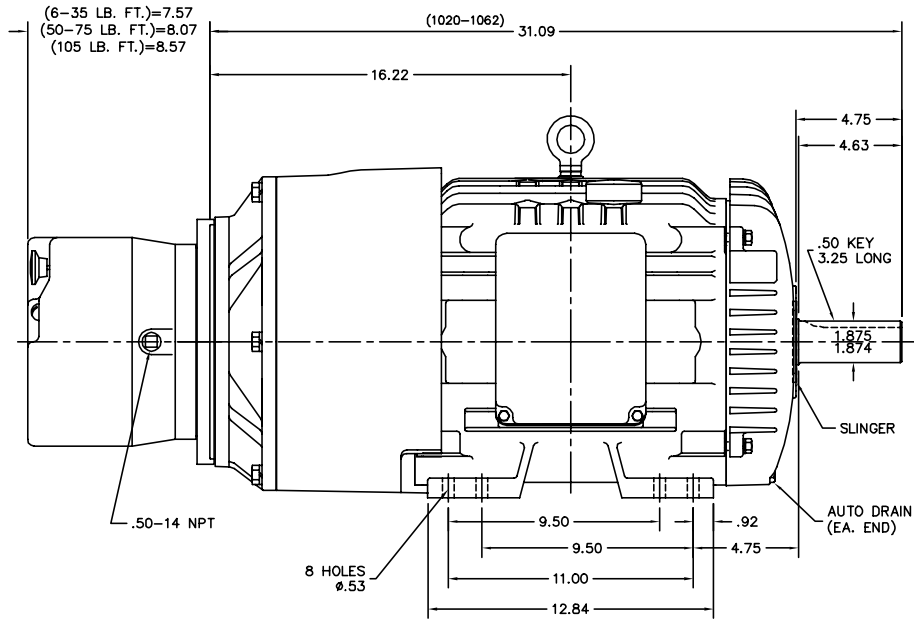

CUSTOMER IS RESPONSIBLE FOR DETERMINING THAT MOTOR PERFORMANCE IS SUITABLE IN THE APPLICATION.

REV. DESC: NEW			
REV. LTR: -	BY: JIM	REVISED: 09:34:36 05/16/2003	TDR: 301786
FILE: AAA00105738			REF: 10LYF574
MTL: -			

**BALDOR ELECTRIC Co.**

HORZ 284-6T TEFC W/BRAKE

10LYF574

CD0005



LOW VOLTAGE  
(2Y)



LINE

HIGH VOLTAGE  
(1Y)

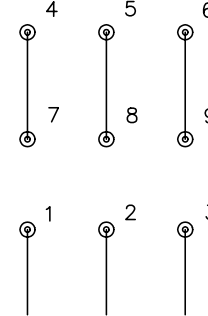

LINE

NOTES:

1. INTERCHANGE ANY TWO LINE LEADS TO REVERSE ROTATION.
2. OPTIONAL THERMOSTATS ARE PROVIDED WHEN SPECIFIED.
3. ACTUAL NUMBER OF INTERNAL PARALLEL CIRCUITS MAY BE A MULTIPLE OF THOSE SHOWN ABOVE.
4. LEAD COLORS ARE OPTIONAL. LEADS MUST ALWAYS BE NUMBERED AS SHOWN.

REV. DESC: REVISE TO SHOW OPTIONAL COLORS

REV. LTR: E BY: JLP

REVISED: 01/19/99 10:15

TDR: 0171435

900000

FILE: AAA00005140

MDL: -

MTL: -

**BALDOR ELECTRIC Co.**

3PH, DV, 9 LEADS

CD0005