

BALDOR® • RELIANCE

Product Information Packet

ELECTRIC MOTOR WHOLESALE.COM

EM7120T

1//1.5HP,975//1170RPM,3PH,50//60HZ,182T

Part Detail							
Revision:	-	Status:	PRD/A	Change #:		Proprietary:	No
Type:	AC	Prod. Type:	0630M	Elec. Spec:	06WGW969	CD Diagram:	
Enclosure:	XPFC	Mfg Plant:		Mech. Spec:	06J001	Layout:	
Frame:	182T	Mounting:	F1	Poles:	06	Created Date:	10-17-2011
Base:	RG	Rotation:	R	Insulation:	B	Eff. Date:	10-21-2011
Leads:	9#16	Literature:		Elec. Diagram:		Replaced By:	
Nameplate NP1426XP							
NO.		CC				010A	
SER.							
SPEC.	06J001W969G1						
CAT.NO.	EM7120T						
HP	1//1.5	T. CODE	T3C				
VOLTS	190/380//230/460						
AMPS	4.4/2.2//5/2.5						
RPM	975//1170						
HZ	50//60	PH	3	CL	B		
SER.F.	1.00	DES	B	CODE	K		
RATING	40C AMB-CONT						
FRAME	182T	NEMA-NOM-EFF	87.5	PF	65		
USABLE AT 208V							

Parts List		
Part Number	Description	Quantity
SA232793	SA 06J001W969G1	1.000 EA
RA219794	RA 06J001W969G1	1.000 EA
36FN3000C01SP	EXFN, PLASTIC, 5.25 OD, .912 ID	1.000 EA
HW3201A05	3/8-16 EYEBOLT	1.000 EA
07CB1000A02	CONDUIT BOX, MODEL 306,EXP. PROOF	1.000 EA
10XN2520A12	O1/4-20X 3/4 HEX HEAD CAP	4.000 EA
HW1001A25	LOCKWASHER 1/4, ZINC PLT .493 OD, .255 I	4.000 EA
WD1000B17	KPA-8C BURNDY TERMINAL	1.000 EA
51XN1032A06	10-32 X .38 HEX SLOTTED SERRATED WASHER	1.000 EA
06EP1706A01	SPECIAL FRONT ENDPLATE X06M - TEFC	1.000 EA
HW4500A19	1/4-28X1/4 SLOTTED PLUG F/S	2.000 EA
10XN3118K20	5/16-18 X 1 1/4 GRADE 5 STEEL ZC PLATED	4.000 EA
HW1001A31	LOCKWASHER 5/16, ZINC PLT.591 OD, .319 I	4.000 EA
HW5100A05	WVY WSHR F/205 & 304 BRGS	1.000 EA
36EP1701A07	PULLEY ENDPLATE 06X 206 BRG	1.000 EA
HW4500A19	1/4-28X1/4 SLOTTED PLUG F/S	2.000 EA
10XN3118K20	5/16-18 X 1 1/4 GRADE 5 STEEL ZC PLATED	4.000 EA
HW1001A31	LOCKWASHER 5/16, ZINC PLT.591 OD, .319 I	4.000 EA
51XB1214A16	12-14X1.00 HXWSSLD SERTYB	1.000 EA
06FH1003A01	FAN COVER, CAST X-PROOF--MACHINING	1.000 EA
51XN1032A14	10-32 X 0.875 HX WS SL SR	4.000 EA
07CB1500A01	CONDUIT BOX LID MACH	1.000 EA
10XN2520A16	1/4-20 X 1 HEX HEAD CAP SCR, ZINC PLATED	4.000 EA
HW1001A25	LOCKWASHER 1/4, ZINC PLT .493 OD, .255 I	4.000 EA

Parts List (continued)		
Part Number	Description	Quantity
HW2501E16	KEY, 1/4 SQ X 1.750	1.000 EA
HA7000A02	KEY RETAINER RING, 1 1/8 DIA, 1 3/8 DIA	1.000 EA
LB1081	LABEL CSA XPROOF	1.000 EA
LB1115	LABEL,LIFTING DEVICE	1.000 EA
85XU0407S04	4X1/4 U DRIVE PIN STAINLESS	6.000 EA
MJ1000A75	GREASE, POLYREX EM EXXON	0.050 LB
MG1025G29	PAINT 789.205 DARK GRAY METALLIC (USE W/	0.028 GA
MG1025Z20	ACTIVATOR WILKOFASST 060.32	0.010 GA
LB1119	WARNING LABEL	1.000 EA
LB1125C02	SUPER-E (STOCK CTN LABEL SUPER-E WITH FL	1.000 EA
LC0145B01	CONNECTION LABEL	1.000 EA
LB1357	ENERGY GUIDE LABEL (BOX LABEL)	1.000 SH
NP1426XP	UL/CSA, CLI GP-D,CLII GP-F&G,CC	1.000 EA
GOPA1000	PACKAGING GROUP	1.000 EA

06LYJ001

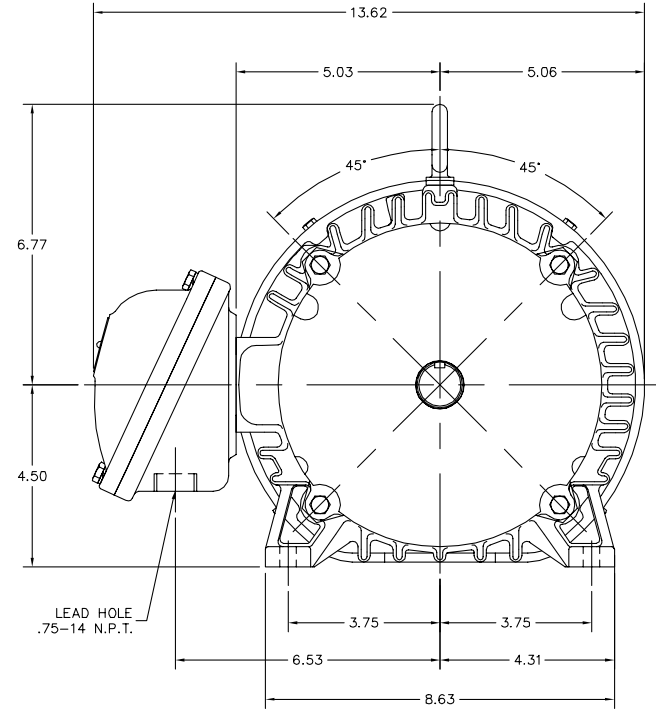
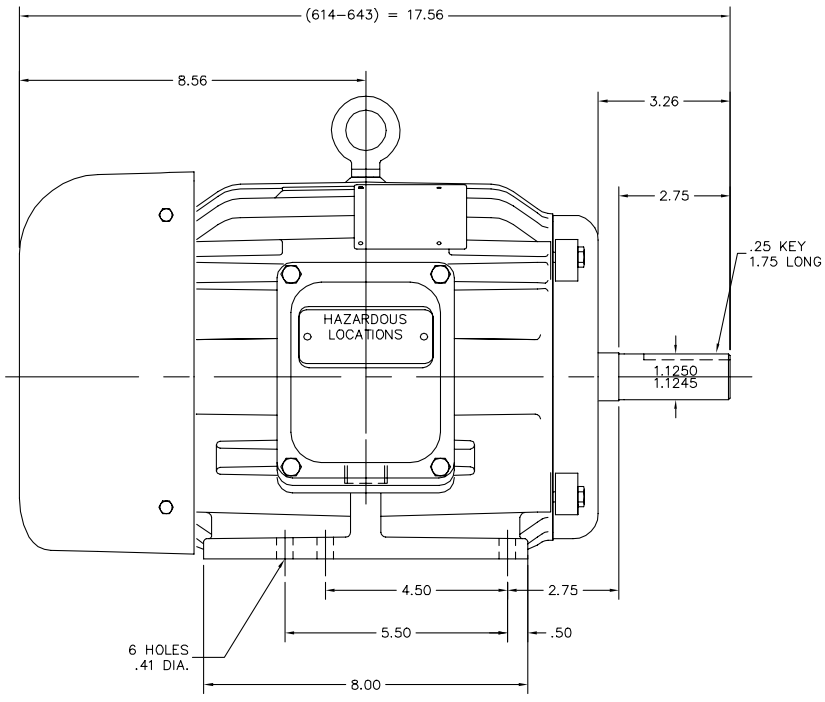

CUSTOMER IS RESPONSIBLE FOR DETERMINING THAT MOTOR PERFORMANCE IS SUITABLE IN THE APPLICATION.

REV. DESC: UPDATE TO INCLUDE 643 STACK	VERSION: 01	TDR: 000000460249
REV. LTR: D	REvised: 08:40:52 03/26/2008	BY: ENSTEKO
FILE: \AAA\00000\715		
MTL: -		

BALDOR • DODGE • RELIANCE

STD HOR 182-4T XPFC 306M CL 1 GP D, CL 2 GP F & G

SH 1 of 1

06LYJ001

CD0005

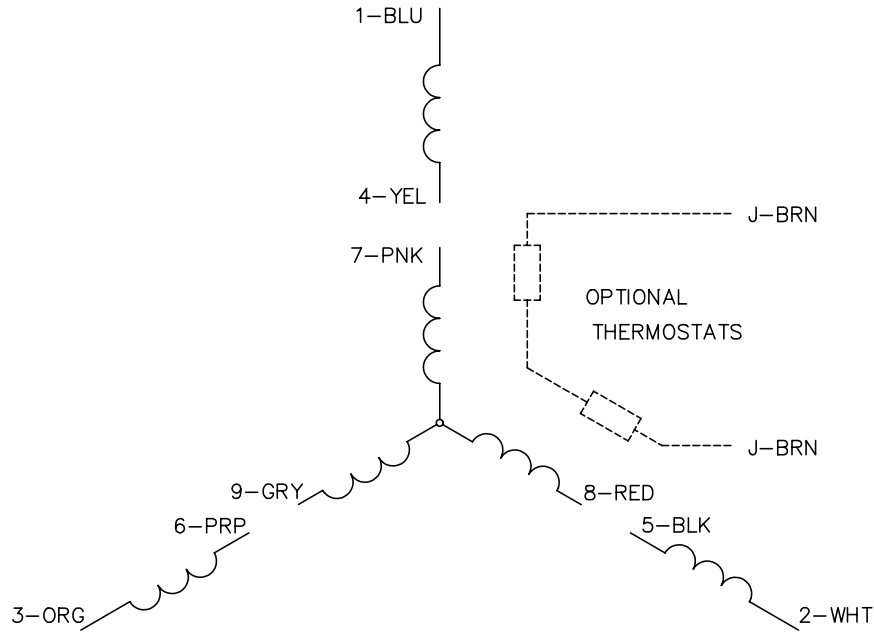

LOW VOLTAGE
(2Y)

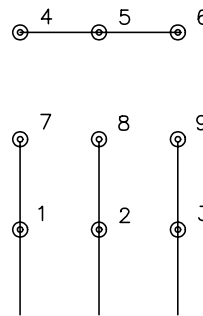

LINE

HIGH VOLTAGE
(1Y)

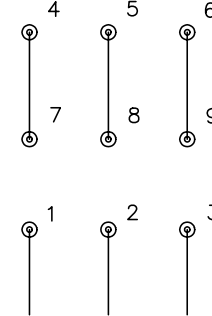

LINE

NOTES:

1. INTERCHANGE ANY TWO LINE LEADS TO REVERSE ROTATION.
2. OPTIONAL THERMOSTATS ARE PROVIDED WHEN SPECIFIED.
3. ACTUAL NUMBER OF INTERNAL PARALLEL CIRCUITS MAY BE A MULTIPLE OF THOSE SHOWN ABOVE.
4. LEAD COLORS ARE OPTIONAL. LEADS MUST ALWAYS BE NUMBERED AS SHOWN.

REV. DESC: REVISE TO SHOW OPTIONAL COLORS			
REV. LTR: E	BY: JLP	REVISED: 01/19/99 10:15	TDR: 0171435
9000D		FILE: AAA00005140	MDL: -
		MTL: -	

BALDOR ELECTRIC Co.

3PH, DV, 9 LEADS

CD0005