

# **BALDOR**® • *RELIANCE*

**Product Information Packet**

**ELECTRIC MOTOR WHOLESAL.COM**

**EM7145T**

**7.5//5HP,3525//2900RPM,3PH,60//50HZ,213T**

Part Detail							
Revision:	A	Status:	PRD/A	Change #:		Proprietary:	No
Type:	AC	Prod. Type:	0733M	Elec. Spec:	07WGW280	CD Diagram:	
Enclosure:	XPFC	Mfg Plant:		Mech. Spec:	07H271	Layout:	
Frame:	213T	Mounting:	F1	Poles:	02	Created Date:	11-01-2010
Base:	RG	Rotation:	R	Insulation:	B	Eff. Date:	04-11-2011
Leads:	9#14	Literature:		Elec. Diagram:		Replaced By:	
Nameplate NP1426XP							
NO.				CC		010A	
SER.							
SPEC.	07H271W280G2						
CAT.NO.	EM7145T						
HP	7.5//5			T. CODE		T3C	
VOLTS	230/460//190/380						
AMPS	17.2/8.6//20.6/10.3						
RPM	3525//2900						
HZ	60//50			PH	3	CL	B
SER.F.	1.00			DES	B	CODE	J
RATING	40C AMB-CONT						
FRAME	213T			NEMA-NOM-EFF	90.2	PF	90
USABLE AT 208V							

Parts List		
Part Number	Description	Quantity
SA210147	SA 07H271W280G2	1.000 EA
RA197408	RA 07H271W280G2	1.000 EA
36FN3000C02	EXFN, PLASTIC, 5.25 OD, 1.175 ID	1.000 EA
HA3210E08	.250X 7/8 PIN 312-57	1.000 EA
HW3201A05	3/8-16 EYEBOLT	1.000 EA
07CB1000A01	CONDUIT BOX MACH	1.000 EA
10XN3118A16	5/16-18X1 HEX HD CAP	4.000 EA
HW1001A31	LOCKWASHER 5/16, ZINC PLT.591 OD, .319 I	4.000 EA
11XW1032G06	10-32 X .38, TAPTITE II, HEX WSHR SLTD U	1.000 EA
WD1000B17	KPA-8C BURNDY TERMINAL	1.000 EA
07EP1707A01	STD FRONT ENDPLATE EXPLOSION PROOF	1.000 EA
HW4500A19	1/4-28X1/4 SLOTTED PLUG F/S	2.000 EA
10XN3816K28	3/8-16 X 1.75 HEX HD CAP SCREW, GRADE 5	4.000 EA
HW1001A38	LOCKWASHER 3/8, ZINC PLT .688 OD, .382 I	4.000 EA
HW5100A06	W2420-025 WVY WSHR (WB)	1.000 EA
07EP1709A01	STANDARD PULLEY ENDPLATE EXPLOSION PROOF	1.000 EA
HW4500A19	1/4-28X1/4 SLOTTED PLUG F/S	2.000 EA
10XN3816K28	3/8-16 X 1.75 HEX HD CAP SCREW, GRADE 5	4.000 EA
HW1001A38	LOCKWASHER 3/8, ZINC PLT .688 OD, .382 I	4.000 EA
51XB1214A20	12-14X1.25 HXWSSLD SERTYB	1.000 EA
07FH1003A01	STANDARD 307 EXPLOSION PROOF FAN HOUSING	1.000 EA
10XN2520A12	O1/4-20X 3/4 HEX HEAD CAP	4.000 EA
07CB1500A01	CONDUIT BOX LID MACH	1.000 EA
10XN2520A16	1/4-20 X 1 HEX HEAD CAP SCR, ZINC PLATED	4.000 EA

Parts List (continued)		
Part Number	Description	Quantity
HW1001A25	LOCKWASHER 1/4, ZINC PLT .493 OD, .255 I	4.000 EA
HW2501F21	KEY, 5/16 SQ X 2.375	1.000 EA
HA7000A02	KEY RETAINER RING, 1 1/8 DIA, 1 3/8 DIA	1.000 EA
85XU0407S04	4X1/4 U DRIVE PIN STAINLESS	6.000 EA
LB1081	LABEL CSA XPROOF	1.000 EA
LB1115	LABEL,LIFTING DEVICE	1.000 EA
MJ1000A75	GREASE, POLYREX EM EXXON	0.050 LB
MG1025Z20	ACTIVATOR WILKOFASST 060.32	0.010 GA
MG1025G29	PAINT 789.205 DARK GRAY METALLIC (USE W/	0.036 GA
LB1119	WARNING LABEL	1.000 EA
LB1172A01	CUSTOM MTR CARTON LABEL LASER PRINTER	1.000 EA
LC0145B01	CONNECTION LABEL	1.000 EA
NP1426XP	UL/CSA, CLI GP-D,CLII GP-F&G,CC	1.000 EA
07PA1011	PKG GRP, 07 CAST IRON PK1181	1.000 EA
10XL3808A28	3/8 X 1 3/4" LAG SCREW	2.000 EA

07LYH271

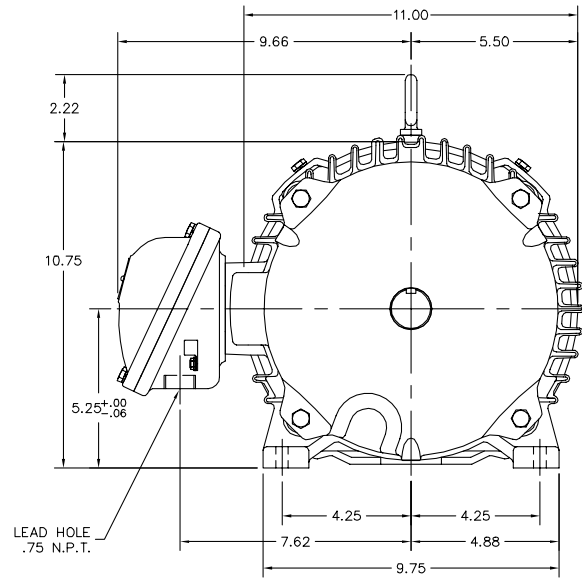
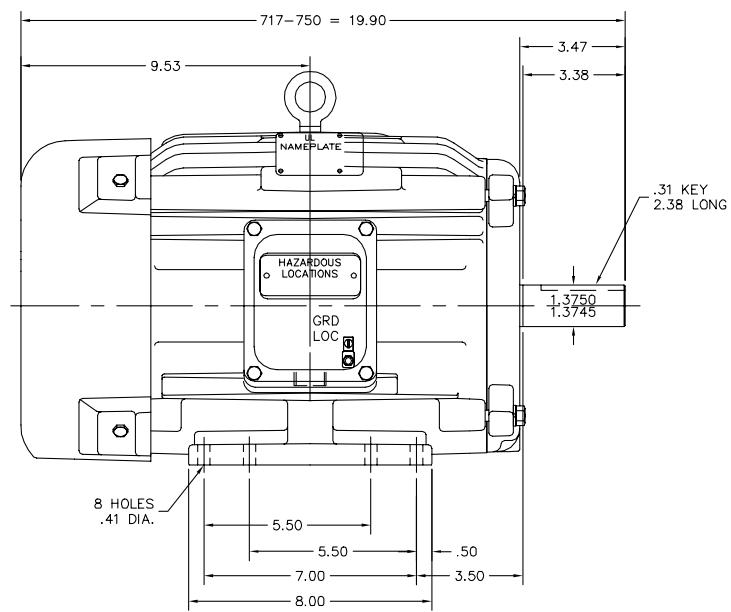

CUSTOMER IS RESPONSIBLE FOR DETERMINING THAT MOTOR PERFORMANCE IS SUITABLE IN THE APPLICATION.

REV. DESC: UPDATE DESCRIPTION		
REV. LTR: B	VERSION: 01	TDR: 000000455347
FILE: \AAA\00005\928	REVISED: 11:23:02 02/04/2008	BY: ENBRAMO
MTL: -		

**BALDOR • DODGE • RELIANCE**

STD HORZ 213-ST XPFC X307M CL-I GP-D CL-II GP F&G

07LYH271

CD0005



LOW VOLTAGE  
(2Y)

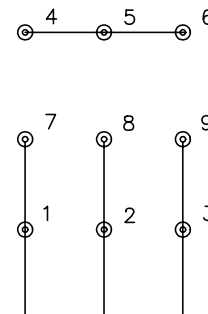

LINE

HIGH VOLTAGE  
(1Y)

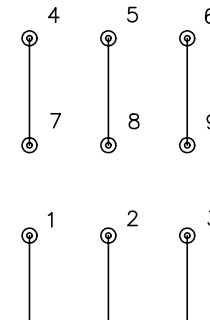

LINE

NOTES:

1. INTERCHANGE ANY TWO LINE LEADS TO REVERSE ROTATION.
2. OPTIONAL THERMOSTATS ARE PROVIDED WHEN SPECIFIED.
3. ACTUAL NUMBER OF INTERNAL PARALLEL CIRCUITS MAY BE A MULTIPLE OF THOSE SHOWN ABOVE.
4. LEAD COLORS ARE OPTIONAL. LEADS MUST ALWAYS BE NUMBERED AS SHOWN.

REV. DESC: REVISE TO SHOW OPTIONAL COLORS			
REV. LTR: E	BY: JLP	REVISED: 01/19/99 10:15	TDR: 0171435
90000		FILE: AAA00005140	MDL: -
		MTL: -	

**BALDOR ELECTRIC Co.**

3PH, DV, 9 LEADS

CD0005