

# **BALDOR® • RELIANCE**

**Product Information Packet**

**ELECTRIC MOTOR WHOLESALE.COM**

**EM7147T-C**

**7.5HP, 1770/1470RPM, 3PH, 60/50HZ, 213T**

Part Detail							
Revision:	B	Status:	PRD/A	Change #:		Proprietary:	No
Type:	AC	Prod. Type:	0735M	Elec. Spec:	07WGX790	CD Diagram:	
Enclosure:	XPFC	Mfg Plant:		Mech. Spec:	07H841	Layout:	
Frame:	213T	Mounting:	F1	Poles:	04	Created Date:	
Base:	RG	Rotation:	R	Insulation:	B	Eff. Date:	01-15-2010
Leads:	9#14	Literature:		Elec. Diagram:		Replaced By:	
Nameplate NP1482XP							
NO.		CC				010A	
SER.							
SPEC.	07H841X790G1						
CAT.NO.	EM7147T-C						
HP	7 1/2/5	T. CODE				T4	
VOLTS	230/460//190/380						
AMPS	19/9.5//16/8						
RPM	1770//1470						
HZ	60//50	PH		3	CL		B
SER.F.	1.00	DES		A	CODE		J
RATING	40C AMB-CONT						
FRAME	213T	NEMA-NOM-EFF		91.7	PF		81
USABLE AT 208V	N/A						

Parts List		
Part Number	Description	Quantity
SA126213	SA 07H841X790G1	1.000 EA
RA116529	RA 07H841X790G1	1.000 EA
37FN3002C01	EXFN, PLASTIC, 6.00 OD, 1.155 ID	1.000 EA
HA3210E08	.250X 7/8 PIN 312-57	1.000 EA
HW3201A05	3/8-16 EYEBOLT	1.000 EA
07CB1000A01	CONDUIT BOX MACH	1.000 EA
10XN3118A16	5/16-18X1 HEX HD CAP	4.000 EA
WD1000B17	KPA-8C BURNDY TERMINAL	1.000 EA
11XW1032G06	10-32 X .38, TAPTITE II, HEX WSHR SLTD U	1.000 EA
07EP1707A07	STD FRONT ENDPLATE EXPLOSION PROOF	1.000 EA
HW4500A19	1/4-28X1/4 SLOTTED PLUG F/S	2.000 EA
10XN3816K28	3/8-16 X 1.75 HEX HD CAP SCREW, GRADE 5	4.000 EA
HW1001A38	LOCKWASHER 3/8, ZINC PLT .688 OD, .382 I	4.000 EA
HW5100A06	W2420-025 WVY WSHR (WB)	1.000 EA
07EP1710A01	STANDARD PULLEY ENDPLATE EXPLOSION PROOF	1.000 EA
HW4500A19	1/4-28X1/4 SLOTTED PLUG F/S	2.000 EA
10XN3816K28	3/8-16 X 1.75 HEX HD CAP SCREW, GRADE 5	4.000 EA
HW1001A38	LOCKWASHER 3/8, ZINC PLT .688 OD, .382 I	4.000 EA
07FH1003A01	STANDARD 307 EXPLOSION PROOF FAN HOUSING	1.000 EA
10XN2520A12	O1/4-20X 3/4 HEX HEAD CAP	4.000 EA
07CB1502A01	CONDUIT BOX LID MACH (DUCTILE IRON)	1.000 EA
84XN2520J16	1/4-20 X 1 SOC HD CAP SCREW	4.000 EA
HW1001A25	LOCKWASHER 1/4, ZINC PLT .493 OD, .255 I	4.000 EA
HW2501F21	KEY, 5/16 SQ X 2.375	1.000 EA

Parts List (continued)		
Part Number	Description	Quantity
HA7000A02	KEY RETAINER RING, 1 1/8 DIA, 1 3/8 DIA	1.000 EA
85XU0407S04	4X1/4 U DRIVE PIN STAINLESS	6.000 EA
LB1081	LABEL CSA XPROOF	1.000 EA
LB1115	LABEL,LIFTING DEVICE	1.000 EA
MJ1000A75	GREASE, POLYREX EM EXXON	0.050 LB
51XB1214A20	12-14X1.25 HXWSSLD SERTYB	1.000 EA
MG1025Z20	ACTIVATOR WILKOFAS 060.32	0.010 GA
MG1025G29	PAINT 789.205 DARK GRAY METALLIC (USE W/	0.036 GA
LB1119	WARNING LABEL	1.000 EA
LB1125C02	SUPER-E (STOCK CTN LABEL SUPER-E WITH FL	1.000 EA
LC0145B01	CONNECTION LABEL	1.000 EA
NP1482XP	UL/CSA, CLI GP-C&D,CLII GP-F&G,CC	1.000 EA
07PA1011	PKG GRP, 07 CAST IRON PK1181	1.000 EA
10XL3808A28	3/8 X 1 3/4" LAG SCREW	2.000 EA
LB1357	ENERGY GUIDE LABEL (BOX LABEL)	1.000 SH

**Performance Data at 460V, 60Hz, 7.5HP (Typical performance - Not guaranteed values)**

General Characteristics							
Full Load Torque:	22.1 LB-FT			Start Configuration:	DOL		
No-Load Current:	4.18 Amps			Break-Down Torque:	69.8 LB-FT		
Line-line Res. @ 25°C.:	1.43 Ohms A Ph / 0.0 Ohms B Ph			Pull-Up Torque:	34.3 LB-FT		
Temp. Rise @ Rated Load:	42 C			Locked-Rotor Torque:	42.2 LB-FT		
Temp. Rise @ S.F. Load:				Starting Current:	68.0 Amps		
Load Characteristics							
% of Rated Load	25	50	75	100	125	150	S.F.
Power Factor:	43.0	65.0	76.0	81.0	83.0	84.0	82.0
Efficiency:	87.4	91.6	92.3	92.0	91.2	90.1	91.5
Speed:	1792.0	1784.0	1777.0	1769.0	1760.0	1750.0	1764.0
Line Amperes:	4.68	5.93	7.53	9.44	11.6	13.9	10.7

Performance Graph at 460V, 60Hz, 7.5HP Typical performance - Not guaranteed values

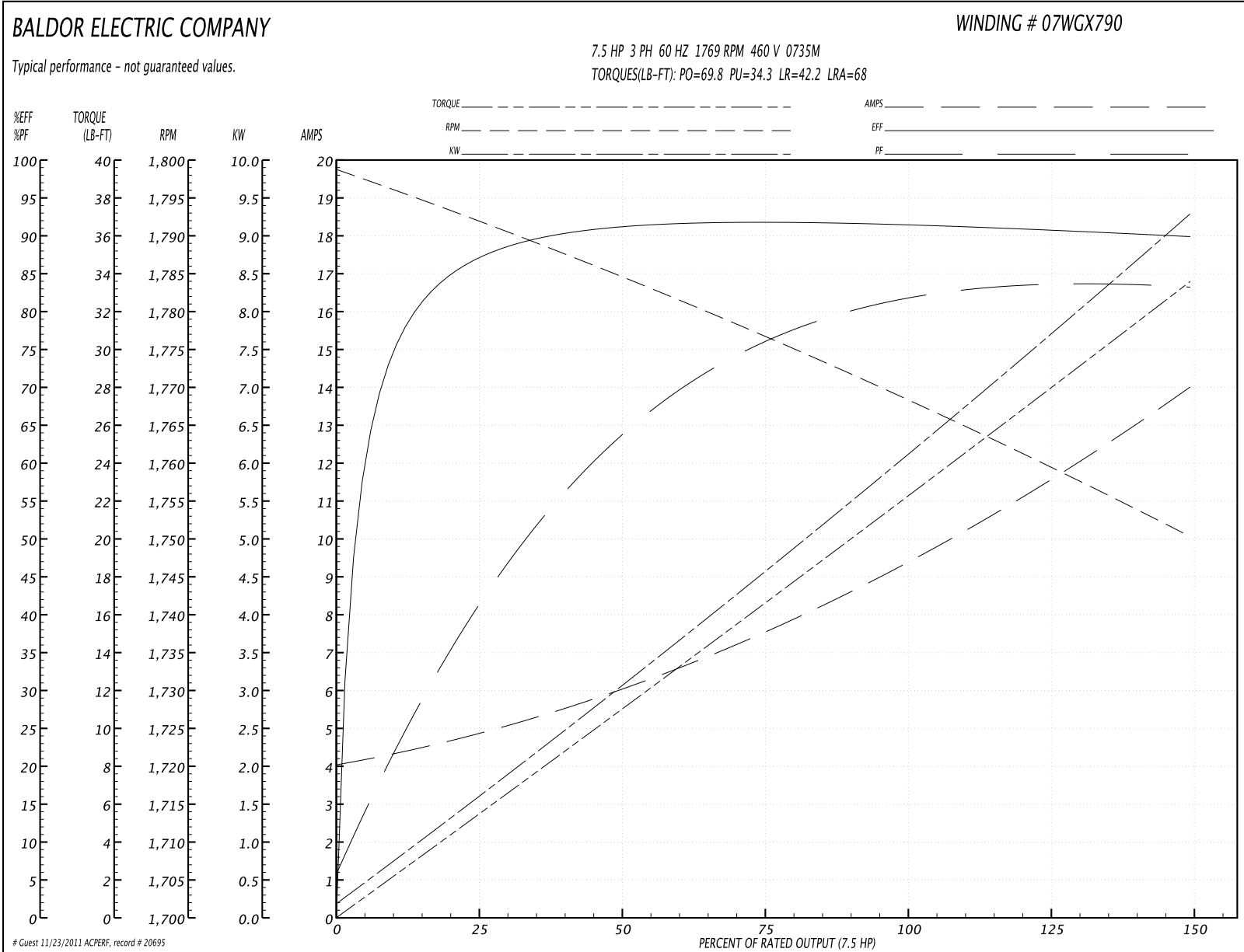

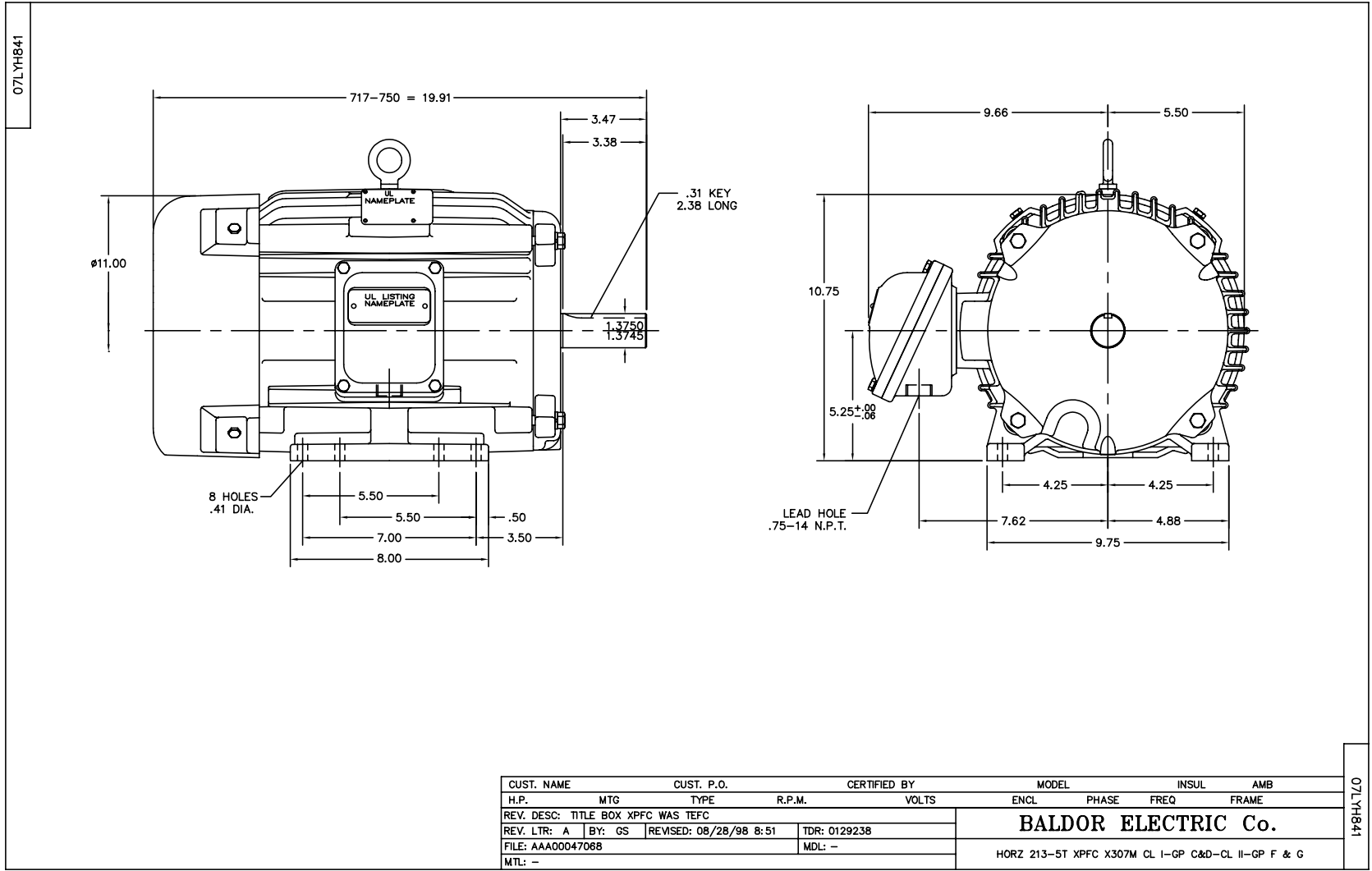

CD0005



LOW VOLTAGE  
(2Y)



LINE

HIGH VOLTAGE  
(1Y)



LINE

NOTES:

1. INTERCHANGE ANY TWO LINE LEADS TO REVERSE ROTATION.
2. OPTIONAL THERMOSTATS ARE PROVIDED WHEN SPECIFIED.
3. ACTUAL NUMBER OF INTERNAL PARALLEL CIRCUITS MAY BE A MULTIPLE OF THOSE SHOWN ABOVE.
4. LEAD COLORS ARE OPTIONAL. LEADS MUST ALWAYS BE NUMBERED AS SHOWN.

REV. DESC: REVISE TO SHOW OPTIONAL COLORS			
REV. LTR: E	BY: JLP	REVISED: 01/19/99 10:15	TDR: 0171435
900000		FILE: AAA00005140	MDL: -
		MTL: -	

**BALDOR ELECTRIC Co.**

3PH, DV, 9 LEADS

CD0005