

BALDOR® • RELIANCE

Product Information Packet

ELECTRIC MOTOR WHOLESAL.COM

EM7170T-C

10//7.5HP,1760//1465RPM,3PH,60//50HZ,215

Part Detail									
Revision:	-	Status:	PRD/A	Change #:		Proprietary:	No		
Type:	AC	Prod. Type:	0748M	Elec. Spec:	07WGY179	CD Diagram:			
Enclosure:	XPFC	Mfg Plant:		Mech. Spec:	07H841	Layout:			
Frame:	215T	Mounting:	F1	Poles:	04	Created Date:	05-19-2010		
Base:	RG	Rotation:	R	Insulation:	B	Eff. Date:	05-27-2010		
Leads:	9#14	Literature:		Elec. Diagram:		Replaced By:			
Nameplate NP1482XP									
NO.					CC	010A			
SER.									
SPEC.	07H841Y179G1								
CAT.NO.	EM7170T-C								
HP	10//7.5				T. CODE	T3C			
VOLTS	230/460//190/380								
AMPS	24.4/12.2//22.6/11.3								
RPM	1760//1465								
HZ	60//50				PH	3	CL	B	
SER.F.	1.00				DES	B	CODE	H	
RATING	40C AMB-CONT								
FRAME	215T				NEMA-NOM-EFF	91.7	PF	83	
USABLE AT 208V									

Parts List		
Part Number	Description	Quantity
SA197074	SA 07H841Y179G1	1.000 EA
RA184511	RA 07H841Y179G1	1.000 EA
37FN3002C01	EXFN, PLASTIC, 6.00 OD, 1.155 ID	1.000 EA
HA3210E08	.250X 7/8 PIN 312-57	1.000 EA
HW3201A05	3/8-16 EYEBOLT	1.000 EA
07CB1000A01	CONDUIT BOX MACH	1.000 EA
10XN3118A16	5/16-18X1 HEX HD CAP	4.000 EA
WD1000B17	KPA-8C BURNDY TERMINAL	1.000 EA
11XW1032G06	10-32 X .38, TAPTITE II, HEX WSHR SLTD U	1.000 EA
07EP1707A07	STD FRONT ENDPLATE EXPLOSION PROOF	1.000 EA
HW4500A19	1/4-28X1/4 SLOTTED PLUG F/S	2.000 EA
10XN3816K28	3/8-16 X 1.75 HEX HD CAP SCREW, GRADE 5	4.000 EA
HW1001A38	LOCKWASHER 3/8, ZINC PLT .688 OD, .382 I	4.000 EA
HW5100A06	W2420-025 WVY WSHR (WB)	1.000 EA
07EP1710A01	STANDARD PULLEY ENDPLATE EXPLOSION PROOF	1.000 EA
HW4500A19	1/4-28X1/4 SLOTTED PLUG F/S	2.000 EA
10XN3816K28	3/8-16 X 1.75 HEX HD CAP SCREW, GRADE 5	4.000 EA
HW1001A38	LOCKWASHER 3/8, ZINC PLT .688 OD, .382 I	4.000 EA
07FH1003A01	STANDARD 307 EXPLOSION PROOF FAN HOUSING	1.000 EA
10XN2520A12	O1/4-20X 3/4 HEX HEAD CAP	4.000 EA
07CB1502A01	CONDUIT BOX LID MACH (DUCTILE IRON)	1.000 EA
84XN2520J16	1/4-20 X 1 SOC HD CAP SCREW	4.000 EA
HW1001A25	LOCKWASHER 1/4, ZINC PLT .493 OD, .255 I	4.000 EA
HW2501F21	KEY, 5/16 SQ X 2.375	1.000 EA

Parts List (continued)		
Part Number	Description	Quantity
HA7000A02	KEY RETAINER RING, 1 1/8 DIA, 1 3/8 DIA	1.000 EA
85XU0407S04	4X1/4 U DRIVE PIN STAINLESS	6.000 EA
LB1081	LABEL CSA XPROOF	1.000 EA
LB1115	LABEL,LIFTING DEVICE	1.000 EA
MJ1000A75	GREASE, POLYREX EM EXXON	0.050 LB
51XB1214A20	12-14X1.25 HXWSSLD SERTYB	1.000 EA
MG1025Z20	ACTIVATOR WILKOFAS 060.32	0.010 GA
MG1025G29	PAINT 789.205 DARK GRAY METALLIC (USE W/	0.036 GA
LB1119	WARNING LABEL	1.000 EA
LB1125C02	SUPER-E (STOCK CTN LABEL SUPER-E WITH FL	1.000 EA
LC0145B01	CONNECTION LABEL	1.000 EA
LB1357	ENERGY GUIDE LABEL (BOX LABEL)	1.000 SH
NP1482XP	UL/CSA, CLI GP-C&D,CLII GP-F&G,CC	1.000 EA
07PA1011	PKG GRP, 07 CAST IRON PK1181	1.000 EA
10XL3808A28	3/8 X 1 3/4" LAG SCREW	2.000 EA

Performance Data at 460V, 60Hz, 10.0HP (Typical performance - Not guaranteed values)

General Characteristics							
Full Load Torque:	29.8 LB-FT			Start Configuration:	DOL		
No-Load Current:	4.44 Amps			Break-Down Torque:	80.9 LB-FT		
Line-line Res. @ 25°C.:	1.08 Ohms A Ph / 0.0 Ohms B Ph			Pull-Up Torque:	40.2 LB-FT		
Temp. Rise @ Rated Load:	64 C			Locked-Rotor Torque:	52.6 LB-FT		
Temp. Rise @ S.F. Load:	80 C			Starting Current:	81.0 Amps		
Load Characteristics							
% of Rated Load	25	50	75	100	125	150	S.F.
Power Factor:	50.0	71.0	80.0	83.0	85.0	85.0	0.0
Efficiency:	90.4	92.5	92.9	92.4	91.0	89.1	0.0
Speed:	1791.0	1782.0	1774.0	1763.0	1751.0	1737.0	0.0
Line Amperes:	5.24	7.1	9.42	12.2	15.2	18.7	0.0

Performance Graph at 460V, 60Hz, 10.0HP Typical performance - Not guaranteed values

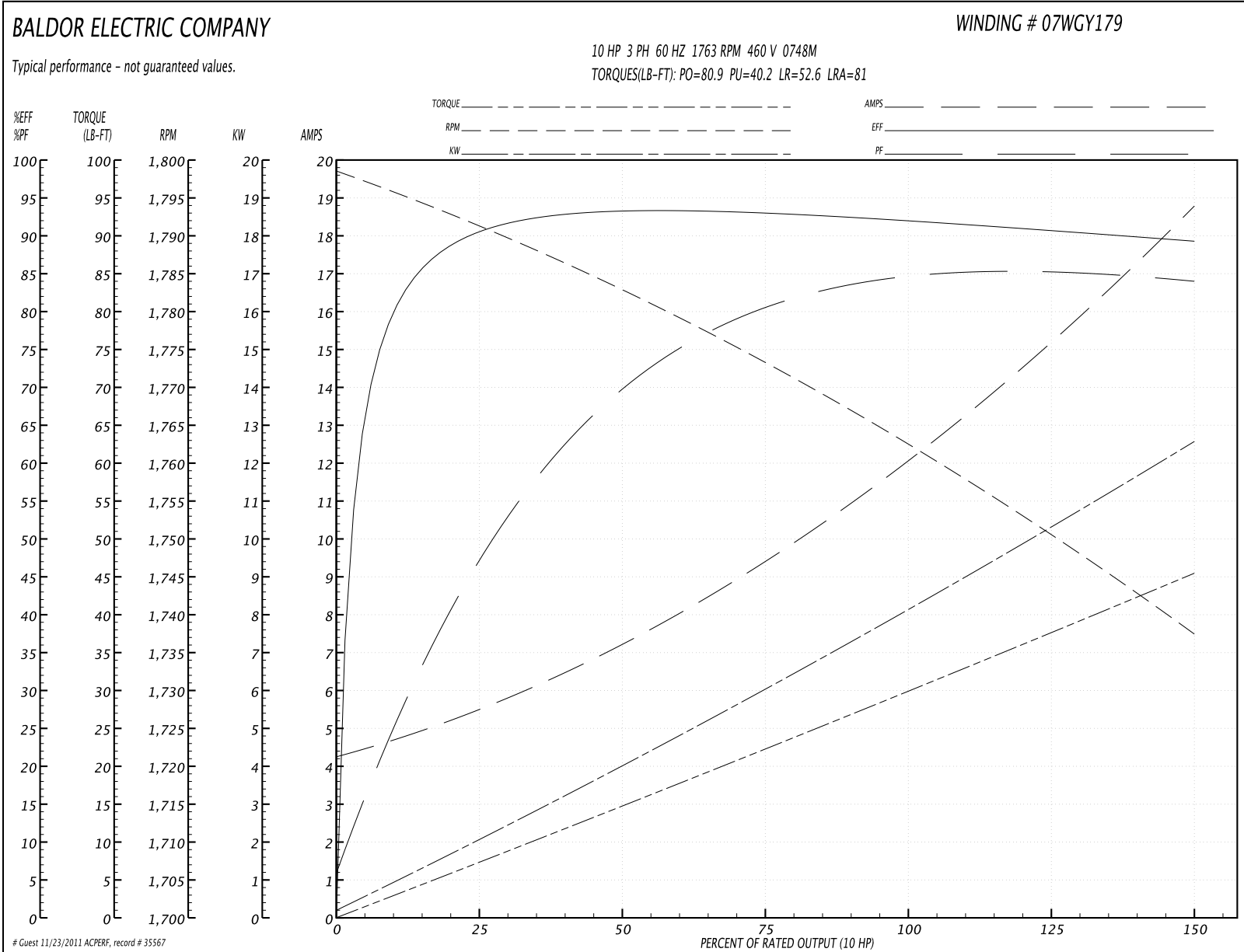

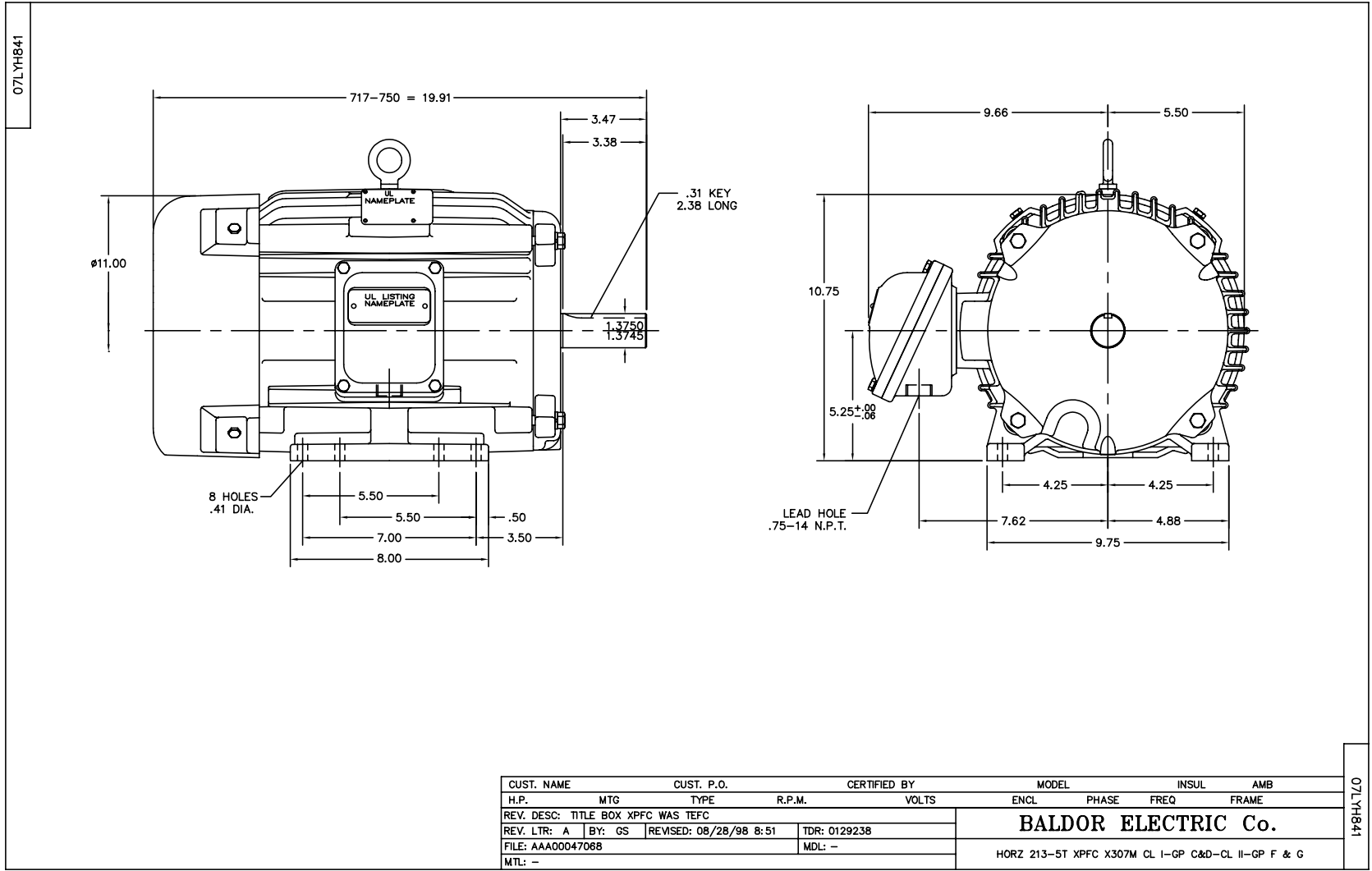

CD0005



LOW VOLTAGE
(2Y)



LINE

HIGH VOLTAGE
(1Y)

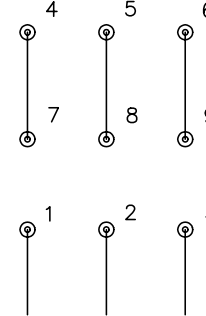

LINE

NOTES:

1. INTERCHANGE ANY TWO LINE LEADS TO REVERSE ROTATION.
2. OPTIONAL THERMOSTATS ARE PROVIDED WHEN SPECIFIED.
3. ACTUAL NUMBER OF INTERNAL PARALLEL CIRCUITS MAY BE A MULTIPLE OF THOSE SHOWN ABOVE.
4. LEAD COLORS ARE OPTIONAL. LEADS MUST ALWAYS BE NUMBERED AS SHOWN.

REV. DESC: REVISE TO SHOW OPTIONAL COLORS			
REV. LTR: E	BY: JLP	REVISED: 01/19/99 10:15	TDR: 0171435
900000		FILE: AAA00005140	MDL: -
		MTL: -	

BALDOR ELECTRIC Co.

3PH, DV, 9 LEADS

CD0005