

BALDOR® • RELIANCE

Product Information Packet

ELECTRIC MOTOR WHOLESAL.COM

GM25120

G.M. K16XF 190/380-415//230/460 VAC

Part Detail							
Revision:	H	Status:	PRD/A	Change #:		Proprietary:	No
Type:	AC	Prod. Type:	2516M	Elec. Spec:	25WGW234	CD Diagram:	
Enclosure:	TEFC	Mfg Plant:		Mech. Spec:		Layout:	
Frame:	G	Mounting:		Poles:	04	Created Date:	08-18-2006
Base:		Rotation:	R	Insulation:	F	Eff. Date:	01-13-2009
Leads:	9#18	Literature:		Elec. Diagram:		Replaced By:	

Nameplate NP1869A01

CAT.NO.	GM25120							
SPEC.	25E638W234G1							
SER.NO								
HP	.14//.17	HZ	50//60					
VOLTS	190/380-415//230/460							
AMB.	40C							
PH	3	CAP					CODE	-
CLASS	F	AMP	.73/.36-.37//.74/.37					
DUTY	CONT							
R.P.M.	11.3/13.8							
TORQ/IN LB	375							
RATIO	120:1	APRV-CSA					APRV-UL	
APRV-CE								

Parts List		
Part Number	Description	Quantity
SA146557	SA 25E638W234G1	1.000 EA
RA135631	RA 25E638W234G1	1.000 EA
LC0005E01	CONN.DIA./WARNING LABEL (LC0005/LB1119)	1.000 EA
25EP2108A62G	EP,25AC DE CL 6201 G GH MTG. C'SUNK THRU	1.000 EA
HW5002A95	N5002-125 32MM BEVELED INTERNAL RET RING	1.000 EA
HW4600C38	SEAL TRANSCOM #10X30X7TC	1.000 EA
25SH4006D08	SHAFT,ROT BDE 25 18-20 FAN PINNED WORM	1.000 EA
WM0038A24	WORM,BE 30.0 INP 1.083 C.D. 913 GEOMET	1.000 EA
MJ5019A01	ADHESIVE LOCTITE #680 WAS BAD4525	0.001 EA
CB0100B02G	CB,EXR 25 .88 LEAD EXIT F2 POSITION	1.000 EA
GS0120	GASKET,CONDUIT BOX FOR CB2000A17	1.000 EA
15XN0832A08	SCREW PAN HD 08-32 X 1/2 (PHILLIPS)	2.000 EA
25EP2113A24G	EP,25AC ODE GP 42C EXR TEFC WFAN CVR MT	1.000 EA
CB0103A00G	CB,LID FOR CB0100 W/GRAY POWDER COATING	1.000 EA
GS0121A01	GASKET, LID FOR CB0100B00	1.000 EA
15XN0832A08	SCREW PAN HD 08-32 X 1/2 (PHILLIPS)	4.000 EA
HW5109A08	WASHER, WAVE SPRING FOR 30MM BORE SMALLE	1.000 EA
55XT0632G03	6-32 X 0.187 RD HD PHILLIPS, SERRATED	1.000 EA
HA3170A19	THRUBOLT, FLATHEAD #8-32 THREADS X 6.000	2.000 EA
25FH4006A02G	HSG,FAN EXR HSG NOTCH EXT TIE BOLT FOR 1	1.000 EA
BFN3712	FAN,PM MOTOR STYLE R	1.000 EA
11XN1032A14	10-32 X 7/8 SCREW HEX SLT HD	2.000 EA
HG0074A04G	HSG,G MACHINED STD.	1.000 EA
84XN1032J08	10-32 X 1/2 SOC HD CAP BKOX	4.000 EA

Parts List (continued)		
Part Number	Description	Quantity
HW3075J05	1/4 X 1/2 GROOVE PIN TYPE H	2.000 EA
HA4021A05	1/16 NPSF-HX SOC PIPE PLUG TAPER DRY SEA	1.000 EA
SG0056A26	SHAFT,ASSY G INP 2RED 4.0/30.0	1.000 EA
SG0056A18	SHAFT,ASSY G OUTP 2RED 0.0/4.0	1.000 EA
CG0011A04G	HSG,CAP G MACHINED 3X 5/16-18 MOUNTING	1.000 EA
HW5109A04	WASHER, SPLIT WAVE SPRING, FOR 32MM BORE	1.000 EA
HW5109A10	WASHER, WAVE SPRING FOR 47MM BORE SMALLE	1.000 EA
84XN2520J16	1/4-20 X 1 SOC HD CAP SCREW	6.000 EA
HW4600D39	SEAL, .750 X 1.250 X .250 SINGLE	1.000 EA
MJ5001A15	SEALER-PERMATEX(LOCTITE) 40479 "THE RIGH	0.030 EA
MJ1000B02	KLUB. GH6-460 GEAR OIL 1 LB	0.050 GA
HW2501D15	KEY, 3/16 X 1.625	1.000 EA
BMH4712	KEY LOCKING RING 3/4"	1.000 EA
NP1869A01	NP,AC STD AD NONE V CE CSA UL GEAR MOTOR	1.000 EA
LB5040	INSTRUCTION TAG, AC & DC	1.000 EA
CPA1001	PACKING GROUP OVERSIZED SINGLE	1.000 EA
LB1125A01SP	STOCK MTR CARTON LABEL LASER PRINTER	1.000 EA
PK3090	2" X 7 1/8 X 6 1/2" CRADLE VIN#1665500	1.000 EA

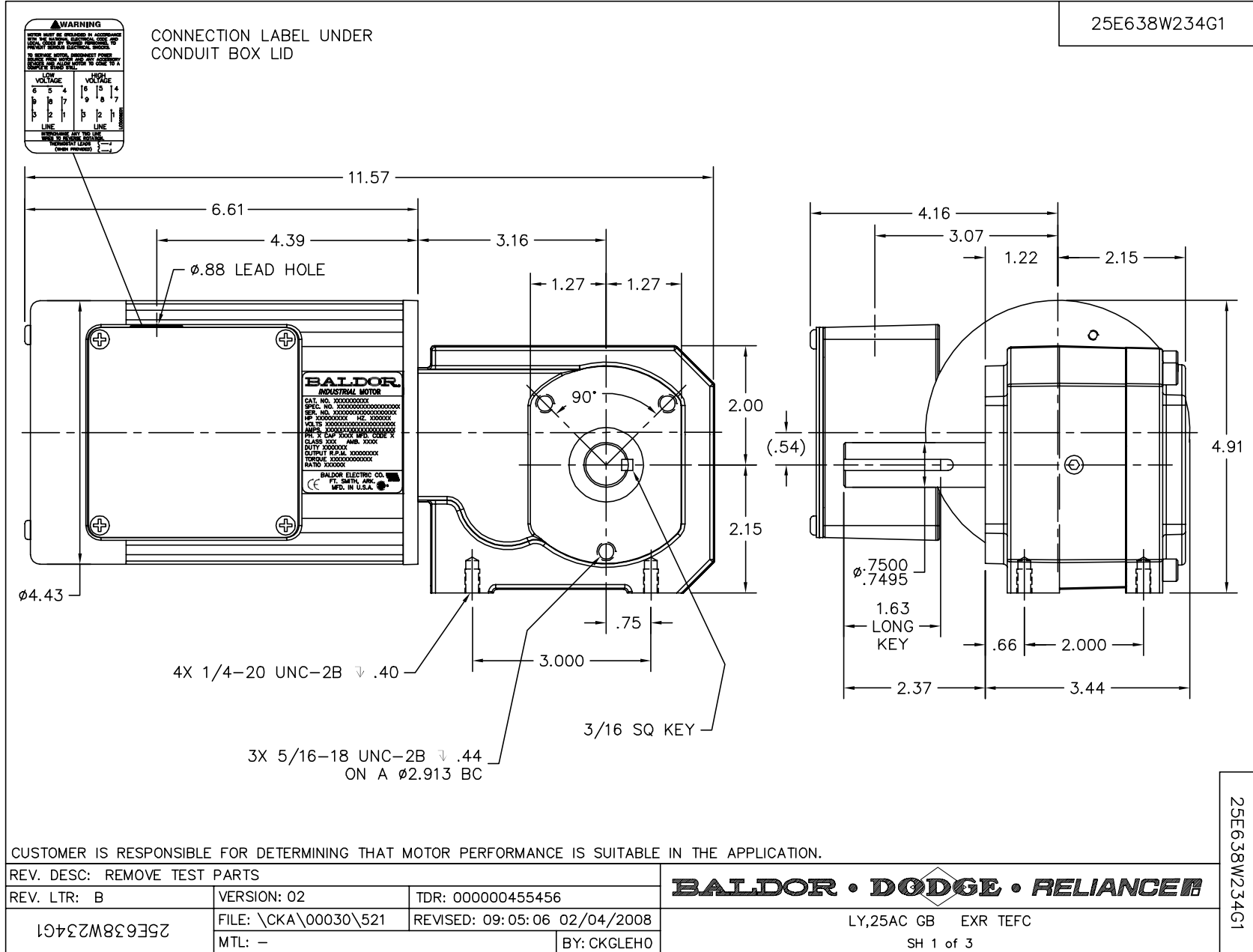

25E638W234G1

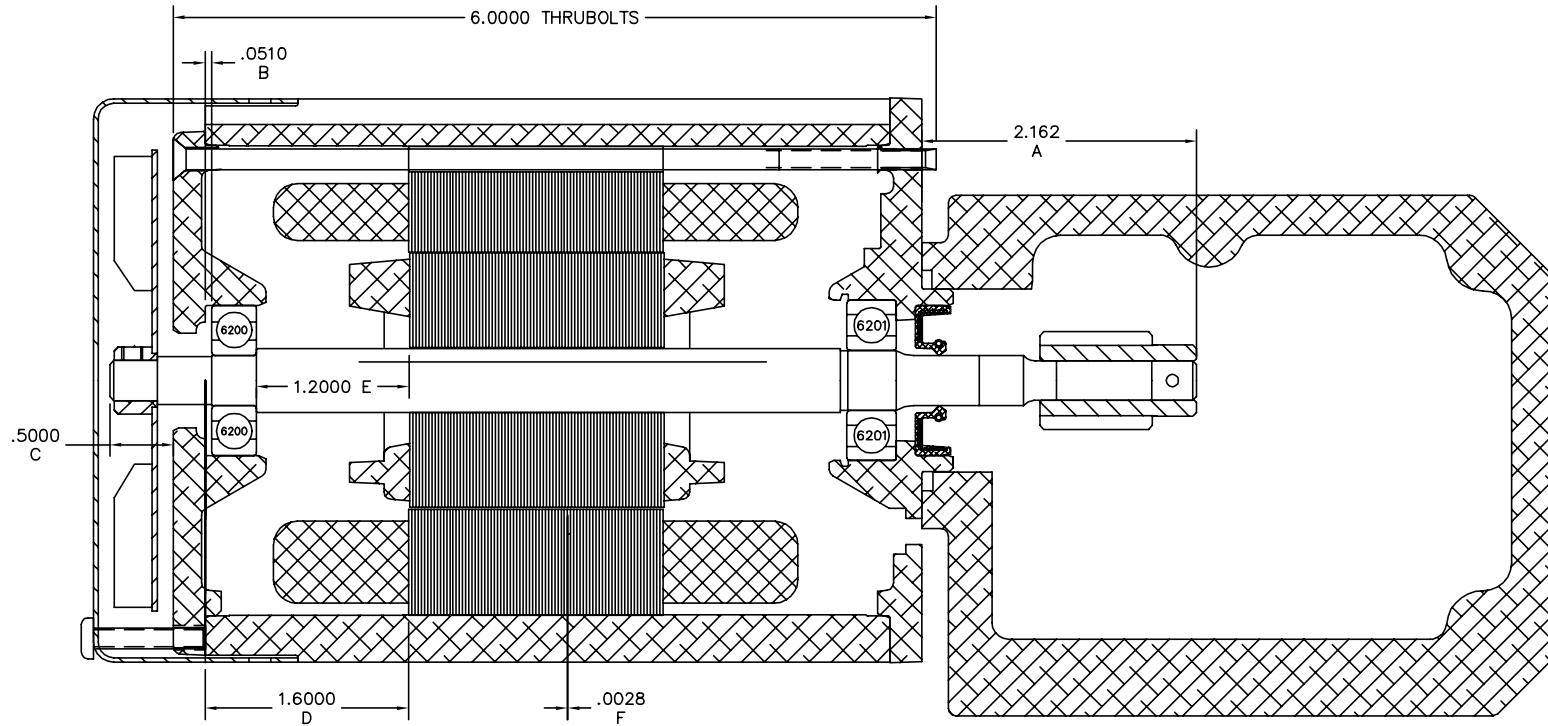

CUSTOMER IS RESPONSIBLE FOR DETERMINING THAT MOTOR PERFORMANCE IS SUITABLE IN THE APPLICATION.

REV. DESC: REMOVE TEST PARTS

REV. LTR: B	VERSION: 02	TDR: 000000455456
194238W234G1	FILE: \CKA\00030\521	REVISED: 09:05:06 02/04/2008
	MTL: -	BY: CKGLEH0

BALDOR • DODGE • RELIANCE

LY,25AC GB EXR TEFC

SH 2 of 3

25E638W234G1

25E638W234G1

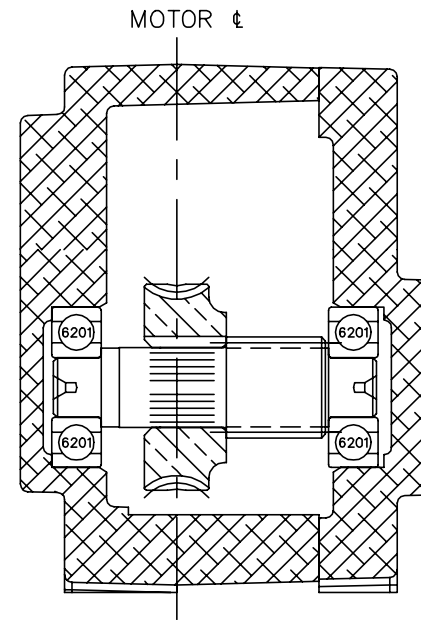
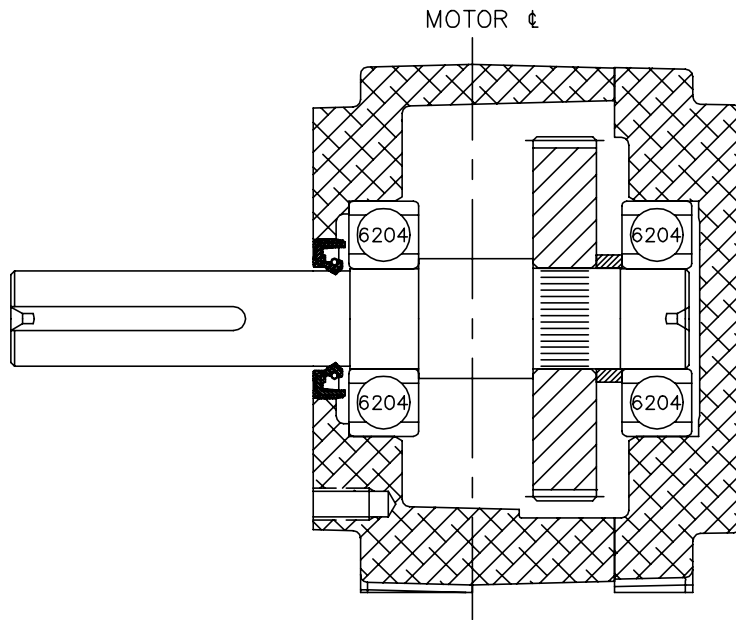

CUSTOMER IS RESPONSIBLE FOR DETERMINING THAT MOTOR PERFORMANCE IS SUITABLE IN THE APPLICATION.

REV. DESC: REMOVE TEST PARTS

REV. LTR: B

VERSION: 02

TDR: 000000455456

BALDOR • DODGE • RELIANCE

25E638W234G1

FILE: \CKA\00030\521

REVISED: 09:05:06 02/04/2008

LY,25AC GB EXR TEFC

MTL: -

BY: CKGLEH0

SH 3 of 3

25E638W234G1

CD0005A05

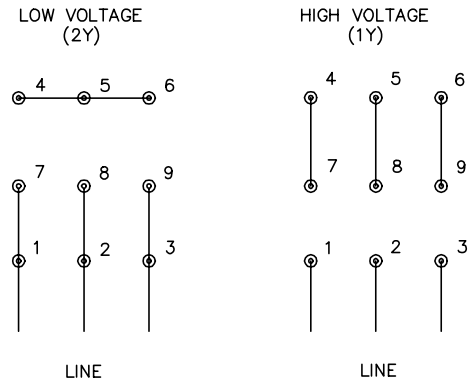
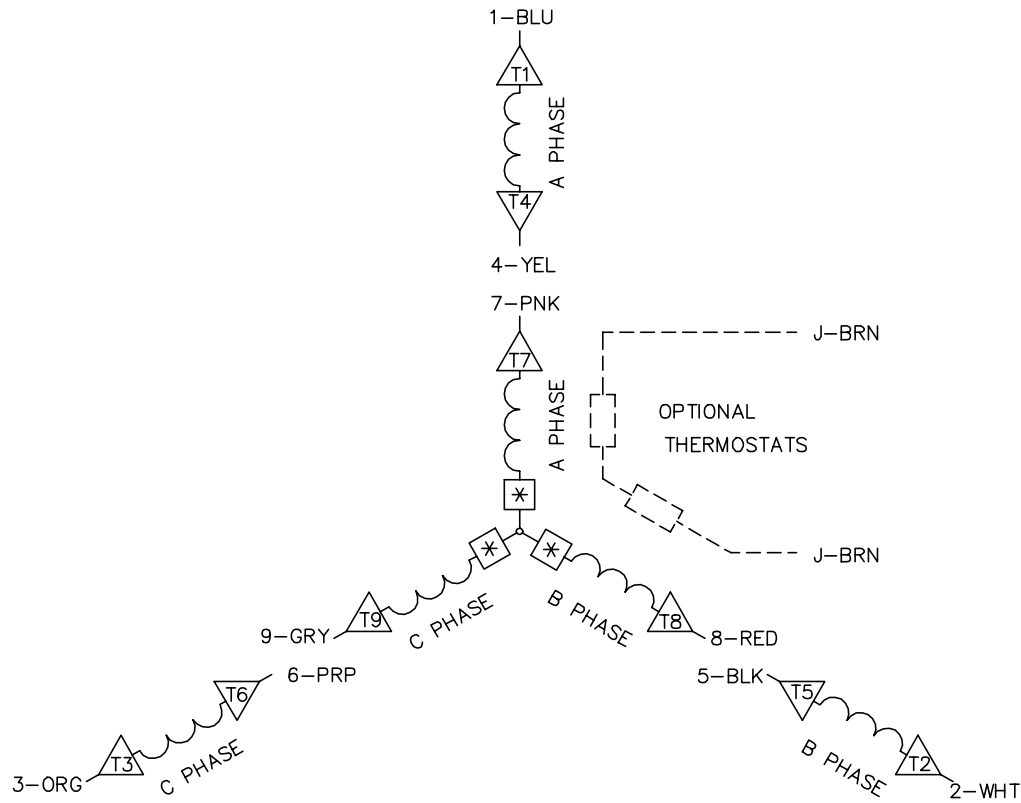

- NOTES:
1. INTERCHANGE ANY TWO LINE LEADS TO REVERSE ROTATION.
 2. OPTIONAL THERMOSTATS ARE PROVIDED WHEN SPECIFIED.
 3. ACTUAL NUMBER OF INTERNAL PARALLEL CIRCUITS MAY BE A MULTIPLE OF THOSE SHOWN ABOVE.
 4. LEAD COLORS ARE OPTIONAL. LEADS MUST ALWAYS BE NUMBERED AS SHOWN.
 5. =MAGNET WIRE COIL END WITH I.D. NUMBER.
 6. =MAGNET WIRE COIL END WITH I.D. SYMBOL.
 7. SEE CW PRINT FOR NEST TO NEST CROSSOVER CONNECTIONS.

REV. DESC: ADD NEST NOTE			
REV. LTR: C	VERSION: 03	TDR: 000000445597	
CD0005A05	FILE: \CKA\00024\847	REVISED: 12:51:06 11/15/2007	
	MTL: -	BY: CKMICRO	

BALDOR • DODGE • RELIANCE

3PH, DV, 9 LEADS, CK

CD0005A05