

# **BALDOR® • RELIANCE**

**Product Information Packet**

**ELECTRIC MOTOR WHOLESAL.COM**

**GPF13514**

**G.M. J28JA 90V DC 8:1 312 RPM**

| Part Detail |      |             |       |                |          |               |            |
|-------------|------|-------------|-------|----------------|----------|---------------|------------|
| Revision:   | D    | Status:     | PRD/A | Change #:      |          | Proprietary:  | No         |
| Type:       | DC   | Prod. Type: |       | Elec. Spec:    | 24WGZ175 | CD Diagram:   |            |
| Enclosure:  | TENV | Mfg Plant:  |       | Mech. Spec:    |          | Layout:       |            |
| Frame:      | JAF  | Mounting:   |       | Poles:         | ///      | Created Date: | 11-26-2007 |
| Base:       |      | Rotation:   |       | Insulation:    | F        | Eff. Date:    | 07-11-2011 |
| Field Type: |      | Literature: |       | Elec. Diagram: |          | Replaced By:  |            |

**Nameplate NP1220A08**

|            |              |    |  |  |          |       |       |  |
|------------|--------------|----|--|--|----------|-------|-------|--|
| CAT.NO.    | GPF13514     |    |  |  |          |       |       |  |
| SER.NO     |              |    |  |  |          |       |       |  |
| SPEC.      | 24A525Z175G2 |    |  |  |          |       |       |  |
| FRAME      | JAF          |    |  |  |          | TYPE  | 2428P |  |
| HP         | .25          | TE |  |  |          |       |       |  |
| VOLTS      | 90           |    |  |  |          |       |       |  |
| AMP        | 2.5          |    |  |  |          |       |       |  |
| F.F.       | 1.26         |    |  |  |          | CLASS | F     |  |
| AMB.       | 40           |    |  |  |          | DUTY  | CONT  |  |
| BRUSHES    | 2/BP5052BP01 |    |  |  |          |       |       |  |
| R.P.M.     | 312          |    |  |  |          |       |       |  |
| TORQ/IN LB | 38           |    |  |  |          |       |       |  |
| RATIO      | 8:1          |    |  |  |          |       |       |  |
| APRV-CE    |              |    |  |  | APRV-CUL |       |       |  |

| Parts List   |  |          |
|--------------|--|----------|
| Part Number  | Description                              | Quantity |
| SA165999     | SA 24A525Z175G2                          | 1.000 EA |
| AA013203     | AA 24A525Z175G2                          | 1.000 EA |
| SR001870     | SR 24A525Z175G2                          | 1.000 EA |
| LC0899A07    | CONNECTION LABEL, DCPM CW ROTATION CE CO | 1.000 EA |
| BP5052BP01SP | BRUSH, GRADE R884 NATIONAL CARBON (FOR 1 | 1.000 EA |
| 24EP3102A01L | EP,24DC 0DE CL 0.63P4                    | 1.000 EA |
| LD0110A24    | ASM,CABLE 18-3 BRN,BLU,G/Y (4R) 40 IN.   | 1.000 EA |
| WD4102A01    | STRN RELIEF HEYCO #1214/M.P. 23MPO6L10   | 1.000 EA |
| BP4529SP     | BRUSH TUBE HOLDER:BBR1097                | 1.000 EA |
| BP4530SP     | BRUSH TUBE CAP AE-57                     | 1.000 EA |
| 80XN1032A04  | 10-32 X 1/4 SET SCREW                    | 2.000 EA |
| 55XT0632G03  | 6-32 X 0.187 RD HD PHILLIPS, SERRATED    | 1.000 EA |
| HW5109A13    | WASHER, WAVE SPRING FOR 26MM BORE SMALLE | 1.000 EA |
| HA3100A11    | THRUBOLT 10-32 X 6.750                   | 2.000 EA |
| HG0040A02L   | HSG,JA EX CLOSED W/ BLACK PWDER COAT     | 1.000 EA |
| HA4021A05    | 1/16 NPSF-HX SOC PIPE PLUG TAPER DRY SEA | 1.000 EA |
| HW5109A10    | WASHER, WAVE SPRING FOR 47MM BORE SMALLE | 1.000 EA |
| 19XN1032A12  | SCREW, HEX WASHER HEAD, #10-32 X .750    | 4.000 EA |
| RM1057       | RUBBER SQUARE RING 1.424 I.D.            | 1.000 EA |
| HA1194B01    | BLADDER,CJK EXPANSION                    | 1.000 EA |
| 15XM0632A06  | SCREW, 6-32X .375, THREAD FORMING        | 3.000 EA |
| BS0114A04L   | BS,JAF OP 6204 W/ BLACK POWDER COAT      | 1.000 EA |
| RM1020A21    | O-RING,3.240 I.D. X .052 BUNA (PGS) BGA4 | 1.000 EA |
| 15XM0832A08  | SCREW, 8-32X .500, THREAD FORMING        | 4.000 EA |

| Parts List (continued) |  |          |
|------------------------|--|----------|
| Part Number            | Description                              | Quantity |
| HW4600D39              | SEAL, .750 X 1.250 X .250 SINGLE         | 1.000 EA |
| BFL1201-015L           | GF,JF OP .281 W/ BLACK POWDER COAT       | 1.000 EA |
| HW2501D10              | KEY, 3/16 SQ X 1.000                     | 1.000 EA |
| ME4000                 | .375-.75" DIA.#SW-04 WOVEN SHAFT PROTECT | 0.021 FT |
| MJ5004A04              | ADHESIVE LOCTITE 609                     | 0.010 EA |
| MJ5001A10              | LOCTITE #510 GASKET ELIMINATOR,51041     | 0.010 EA |
| 84XN2520J08            | 1/4-20 X 1/2 SOC HD CAP SCREW            | 4.000 EA |
| MJ1000B02              | KLUB. GH6-460 GEAR OIL 1 LITER           | 0.030 GA |
| NP1220A08              | NP,DC STD AD NONE V GEAR MOTOR CE CUL    | 1.000 EA |
| LB5040                 | INSTRUCTION TAG, AC & DC                 | 1.000 EA |
| CPA1000                | PACKING GROUP STD. SINGLE                | 1.000 EA |
| LB1171                 | LABEL CARTON 6X6 ON LINE BLANK ROLLS     | 1.000 EA |
| MG2000A14              | RUST VETO 342 RUST INHIBITOR             | 0.001 GA |

| Accessories |   |            |
|-------------|---|------------|
| Part Number | Description                             | Multiplier |
| BC130       | FRAC DC ANALOG,115AC,50/60HZ,3A,1       | E9         |
| BC138       | KBWM-120 120VAC .25-HP SCR CTL, N       | E9         |
| BC140       | CS2934A,120/240VAC .5/1-HP SCR CTL,NEMA | E9         |
| BC140-FBR   | W/FOR BRAKE REV SWITCH                  | E9         |
| BC141       | CHASSIS MOUNT FSCN 3000A20              | E9         |
| BR0050      | PLUG IN RESISTOR                        | E9         |



24A525Z175G2

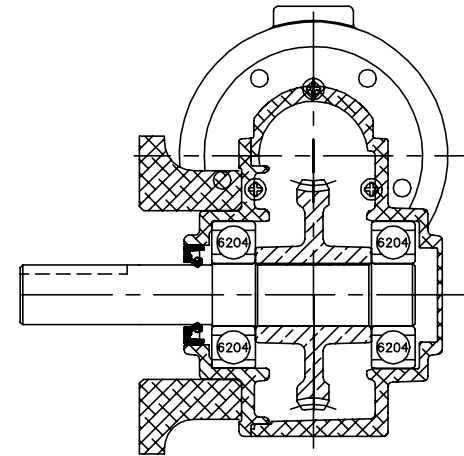
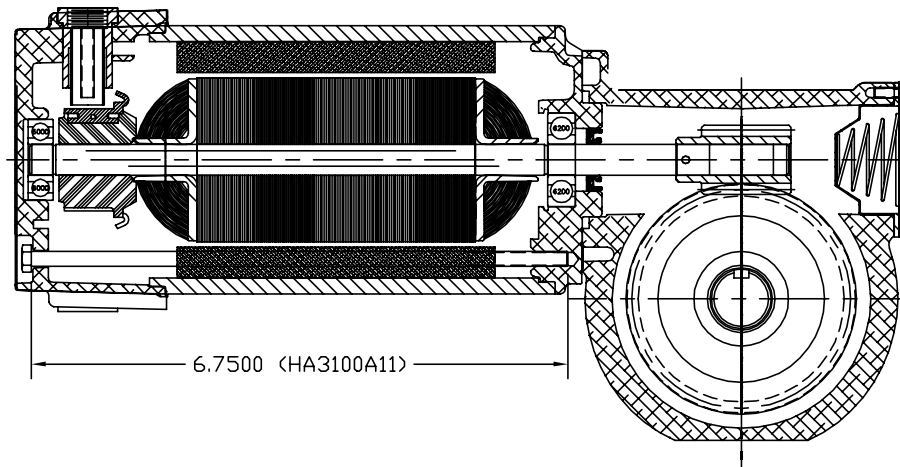

CUSTOMER IS RESPONSIBLE FOR DETERMINING THAT BALDOR'S PRODUCT WILL PERFORM SUITABLY IN THE INTENDED APPLICATION.

|   |                              |                   |
|---|------------------------------|-------------------|
| REV. DESC: CHANGE OUTPUT SHAFT TOL TO .750/.749 |                              |                   |
| REV. LTR: A                                     | VERSION: 01                  | TDR: 000000714997 |
| FILE: \CKA\00033\446                            | REVISED: 11:08:32 10/10/2011 |                   |
| MTL: -  | BY: CKJASWO                  |                   |

**BALDOR**

LY,24DC JAF DOM TENV 1.500 0.750 KEY (GPF13514)

SH 2 of 2

24A525Z175G2

CD1900

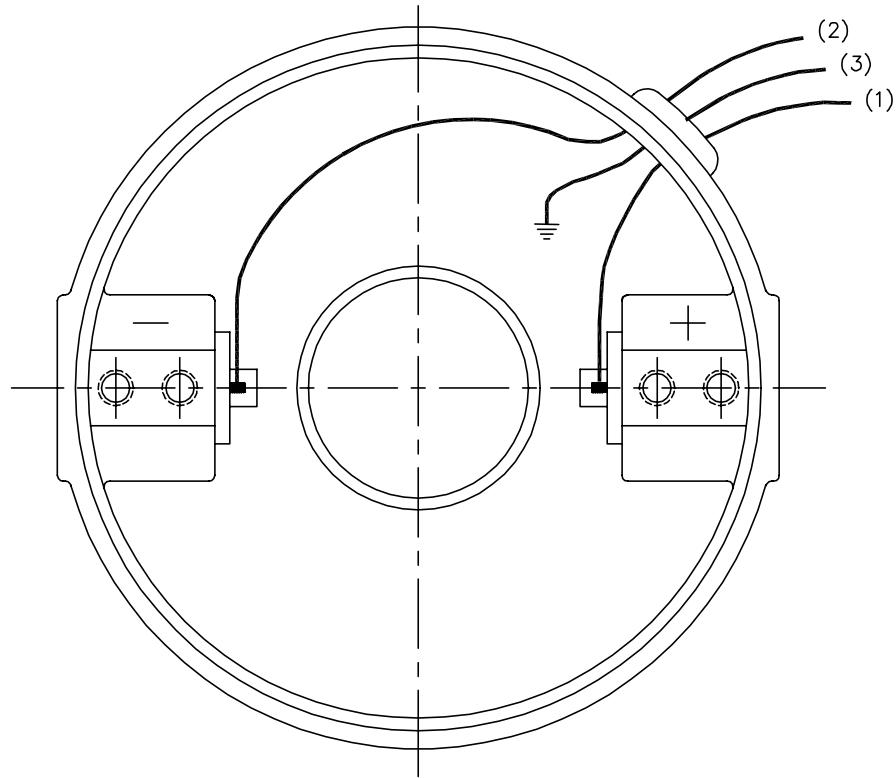

VIEWED FROM  
DRIVE END

(1) COLOR MAY BE  
RED  
WHT  
BLU

(2) COLOR MAY BE  
BLK  
BRN

(3) COLOR WHEN REQ.  
GRN  
GRN/YEL

|                |         |                              |             |
|----------------|---------|------------------------------|-------------|
| REV. DESC: NEW |         |                              |             |
| REV. LTR: -    | BY: PAW | REVISED: 09:34:46 09/16/2004 | TDR: 341564 |
| 006100         |         | FILE: CKA00025831            | REF: CD1900 |
|                |         | MTL: -                       |             |

**BALDOR ELECTRIC Co.**

PM,2LD,REV,TANG,CK

CD1900