

BALDOR® • RELIANCE

Product Information Packet

ELECTRIC MOTOR WHOLESAL.COM

GPP233120

.5HP,DC,PSSH-0,2314P,TENV,GM

Part Detail							
Revision:	T	Status:	PRD/A	Change #:		Proprietary:	No
Type:	DC	Prod. Type:		Elec. Spec:	23WGZ007	CD Diagram:	
Enclosure:	TENV	Mfg Plant:		Mech. Spec:		Layout:	
Frame:	PSSH	Mounting:		Poles:	///	Created Date:	
Base:		Rotation:		Insulation:	F	Eff. Date:	04-11-2012
Field Type:		Literature:		Elec. Diagram:		Replaced By:	

Nameplate NP1220A08

CAT.NO.	GPP233120						
SER.NO							
SPEC.	23A276Z007G1						
FRAME	PSSH				TYPE		2314P
HP	1/22	TE					
VOLTS	180DC						
AMP	.30						
F.F.	1.35				CLASS		F
AMB.	40				DUTY		CONT
BRUSHES	2/BP5060BF02						
R.P.M.	19						
TORQ/IN LB	118						
RATIO	90:1						
APRV-CE					APRV-CUL		

Parts List		
Part Number	Description	Quantity
SA078154	SA 23A276Z007G1	1.000 EA
AA007599	AA 23A276Z007G1	1.000 EA
BP5060BF02SP	1/8X3/16 GRD A252 BRUSH CARBONE#BAL-40	1.000 EA
MJ5005A02	DYNA-WEIGHT COMPOUND BAL-1-FS,16#/KIT,	0.010 LB
HG0044A04BL	HSG,PSSH EP STD 23 FRAME MOUNTING 4 BOR	1.000 EA
BMH1729	WASHER,PREC 1.020"X.628"X.020"	1.000 EA
HW5002A42	N5002-102 RET RING INTERNBEVELED F/6000	1.000 EA
HW3064E05	1/8 X 1/2 PIN DRIVE LOK TYPE H	1.000 EA
HW4600D28	SEAL,10X20X4MM TCM #03907815PSCW	1.000 EA
MJ5082A02	ADHESIVE,KIT PERMABOND TA04592K002L0101	0.002 EA
23EP3108A01L	EP,23DC ODE CL 0.63 P4	1.000 EA
HW5109A06	WASHER, WAVE SPRING FOR 22MM BORE SMALLE	1.000 EA
WD4102A01	STRN RELIEF HEYCO #1214/M.P. 23MPO6L10	1.000 EA
LD0110A29	ASM,CABLE 40 18-3 BRN,BLU,G/Y (4) 23F	1.000 EA
55XT0632G03	6-32 X 0.187 RD HD PHILLIPS, SERRATED	1.000 EA
BP4517	BRUSH TUBE ASM	2.000 EA
80XN0632J03	SCREW, 6-32 X 3/16", SHS, AS	2.000 EA
BP4515SP	BRUSH CAP #AE-51	1.000 EA
HA3170A09	THRUBOLT,FLAT HD. #8-32 THDS X 4.187 LON	1.000 EA
SG0047A21	SHAFT,ASSY PSSH LONG INT1 4RED 2.0/5.0	1.000 EA
SG0047A22	SHAFT,ASSY PSSH LONG INT2 4RED 3.0/2.0	1.000 EA
SG0047A05	SHAFT,ASSY PSSH LONG INT3 4RED 3.0/3.0	1.000 EA
SG0047A23	SHAFT,ASSY PSSH LONG OUTP 4RED 0.0/3.0	1.000 EA
CG0001A01BL	HSG,PSSH CAP STD 4 BORE MACH.	1.000 EA

Parts List (continued)		
Part Number	Description	Quantity
BH1163A02	SCE88 INA NEEDLE ROL SM21	1.000 EA
HW4600C29	SEAL, TCM #0507416 SCW .50X.75X.165 RB	1.000 EA
RM1020A21	O-RING,3.240 I.D. X .052 BUNA (PGS) BGA4	1.000 EA
15XM0832A08	SCREW, 8-32X .500, THREAD FORMING	4.000 EA
MJ1000A81	GREASE, SYN-TECH NS-8301-G	0.030 LB
LC0899A07	CONNECTION LABEL, DCPM CW ROTATION CE CO	1.000 EA
NP1220A08	NP,DC STD AD NONE V GEAR MOTOR CE CUL	1.000 EA
LB1451	WARNING LABEL, CE WARNING SYMBOLS ONLY	1.000 EA
LB5040	INSTRUCTION TAG, AC & DC	1.000 EA
CPA1000	PACKING GROUP STD. SINGLE	1.000 EA
LB1171	LABEL CARTON 6X6 ON LINE BLANK ROLLS	1.000 EA

Accessories		
Part Number	Description	Multiplier
LB73	"L" BRACKET KIT FOR PSSH GEARBOX-BLACK	A8
LB73GR	"L" BRACKET KIT FOR PSSH GEARBOX-GRAY	A8
BC139	.25HP-230V/SCR CNTL,AC,HP RES REQ.	E9
BC140	CS2934A,120/240VAC .5/1-HP SCR CTL,NEMA	E9
BC140-FBR	W/FOR BRAKE REV SWITCH	E9
BR0510	PLUG IN RESISTOR	E9

23A276Z007G1

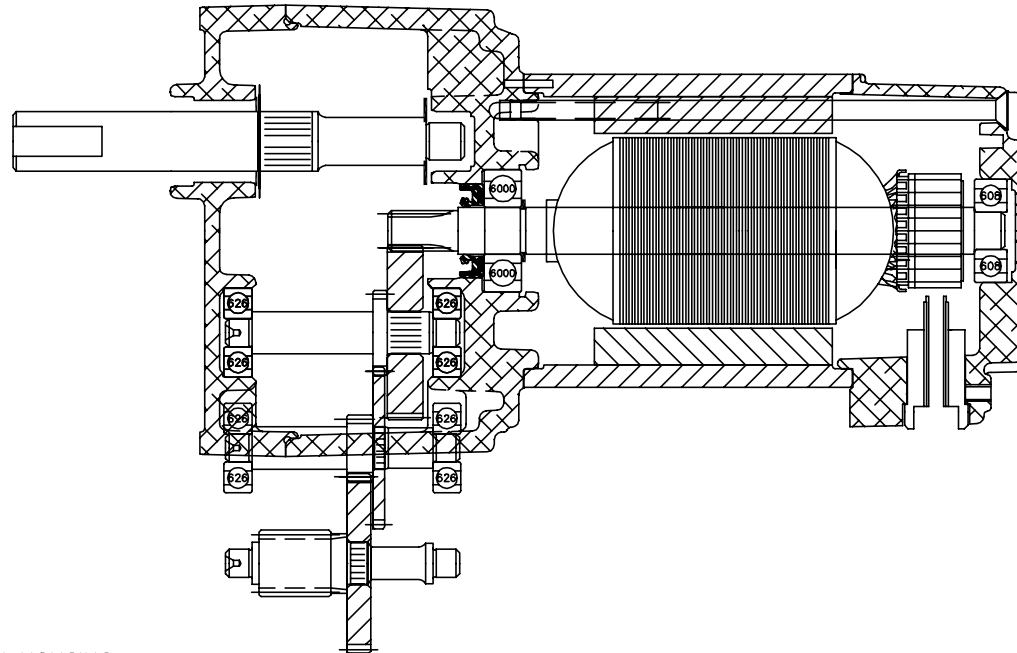
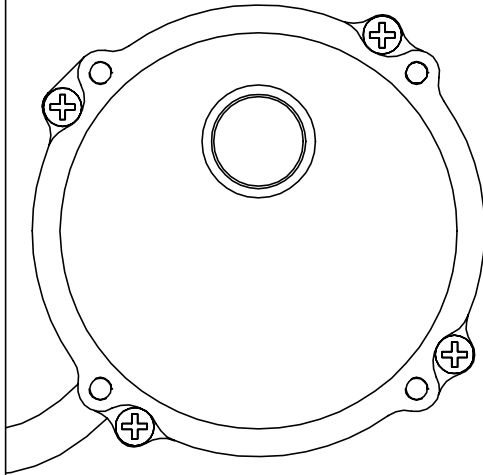

NOTES:

- 1) REMOVE SPRING FROM INPUT SEAL (HW4600D28) BEFORE INSTALING IN HOUSING.
- 2) MAGNETIZE AND CONNECT STANDARD.
- 3) ATTACH LEAD MARKERS ON LEADS.
- 4) GEARHEAD IS FILLED WITH GREASE.

CUSTOMER IS RESPONSIBLE FOR DETERMINING THAT BALDOR'S PRODUCT WILL PERFORM SUITABLY IN THE INTENDED APPLICATION.

REV. DESC: ADD LB1451		
REV. LTR: D	VERSION: 04	TDR: 000000717000
FILE: \CKA\00022\751		REVISED: 03:09:34 10/17/2011
MTL: -		BY: CKAPRBO

BALDOR • DODGE • RELIANCE

LY,23DC PSSH DOM TENV .50X1.56 EXT W/FLAT SHORT

SH 2 of 2

23A276Z007G1

CD1899



(1) COLOR MAY BE
RED
WHT
BLU

(2) COLOR MAY BE
BLK
BRN

(3) COLOR WHEN REQ.
GRN
GRN/YEL

VIEWS FROM
DRIVE END

REV. DESC: NEW			
REV. LTR: -	BY: PAW	REVISED: 09:06:34 09/16/2004	TDR: 341564
668100		FILE: CKA00025830	REF: CD1899
		MTL: -	

BALDOR ELECTRIC Co.

PM,2LD,REV,TANG,CK

CD1899