

BALDOR® • RELIANCE

Product Information Packet

ELECTRIC MOTOR WHOLESAL.COM

IDXM7054T

15HP, 1765RPM, 3PH, 60HZ, 254TC, 0942M, XPFC, F

Part Detail							
Revision:	H	Status:	PRD/A	Change #:		Proprietary:	No
Type:	AC	Prod. Type:	0942M	Elec. Spec:	09WGW980	CD Diagram:	
Enclosure:	XPFC	Mfg Plant:		Mech. Spec:	09E963	Layout:	
Frame:	254TC	Mounting:	F1	Poles:	04	Created Date:	05-06-2008
Base:	RG	Rotation:	R	Insulation:	F	Eff. Date:	06-24-2011
Leads:	9#12	Literature:		Elec. Diagram:		Replaced By:	

Nameplate NP0890XP

NO.		TEMP CODE	T2B						
SPEC.	09E963W980G1	MX RPM	2700						
CAT.NO.	IDXM7054T	INV.TYPE	PWM						
HP	15	C HP FR	60	C HP TO	90				
VOLTS	230/460	CT HZ FROM	30	CT HZ TO	60				
AMPS	36/18	VT HZ FROM	6	VT HZ TO	60				
RPM	1765	DES	B	WK2	1.84	PH	3	CL	F
HZ	60	SER.F.	1.00	NOM.EFF.	92.4	SL HZ	1.16		
MAG CUR	13.9/6.95								
RATING	40C AMB-CONT								
FRAME	254TC	CC	010A						
S/N									

Parts List		
Part Number	Description	Quantity
SA063927	SA 09E963W980G1	1.000 EA
RA058101	RA 09E963W980G1	1.000 EA
MJ5000A01	SEALANT, CHICO A COMPOUND	0.050 LB
09CB1000A01SP	CONDUIT BOX, MACH	1.000 EA
10XN3118K16	5/16-18 X 1" GRADE #5, STL, ZINC PLATE	4.000 EA
HW1001A31	LOCKWASHER 5/16, ZINC PLT.591 OD, .319 I	4.000 EA
WD1000B16	KPA-4C BURNDY TERMINAL	1.000 EA
10XN2520K06	1/4-20 X 3/8" HX HD SCREWGRADE 5, ZINC P	1.000 EA
HW1001A25	LOCKWASHER 1/4, ZINC PLT .493 OD, .255 I	1.000 EA
09EP1700A01	FR ENDPLATE, MACH	1.000 EA
10XN3816K28	3/8-16 X 1.75 HEX HD CAP SCREW, GRADE 5	4.000 EA
HW1001A38	LOCKWASHER 3/8, ZINC PLT .688 OD, .382 I	4.000 EA
HW5100A08	W3118-035 WVY WSHR (WB)	1.000 EA
10XN2520K36	1/4-20 X 2.25" HX HD SCRWGRADE 5, ZINC P	4.000 EA
HW1001A25	LOCKWASHER 1/4, ZINC PLT .493 OD, .255 I	4.000 EA
09EP1708A02	FACE MTD. ENDPLATE, MACH X-PROOF (NEW DE	1.000 EA
10XN3816K28	3/8-16 X 1.75 HEX HD CAP SCREW, GRADE 5	4.000 EA
HW1001A38	LOCKWASHER 3/8, ZINC PLT .688 OD, .382 I	4.000 EA
09FH1004A01	FAN COVER, MACH	1.000 EA
10XN2520K14	1/4-20 X .88 HEX GRD 5 (20001)	3.000 EA
HW1001A25	LOCKWASHER 1/4, ZINC PLT .493 OD, .255 I	3.000 EA
09CB1500A01SP	CONDUIT BOX LID, MACH	1.000 EA
10XN2520K16	1/4-20 X 1" HX HD SCRW GRADE 5, ZINC P	6.000 EA
HW1001A25	LOCKWASHER 1/4, ZINC PLT .493 OD, .255 I	6.000 EA

Parts List (continued)		
Part Number	Description	Quantity
HW2501G25	KEY, 3/8 SQ X 2.875	1.000 EA
LB1115	LABEL,LIFTING DEVICE	1.000 EA
HW4500A20	1/8NPT SL PIPE PLUG	2.000 EA
MJ1000A75	GREASE, POLYREX EM EXXON	0.080 LB
HW4500A20	1/8NPT SL PIPE PLUG	2.000 EA
09FN3001A01SP	EXTERNAL FAN, PLASTIC	1.000 EA
HW2500A25	WOODRUFF KEY USA #1008 #BLOW CARBON STEE	1.000 EA
51XB1214A20	12-14X1.25 HXWSSLD SERTYB	1.000 EA
MG1025G05	PAINT 789.201 (WILCO) DARK GRAY METALLIC	0.050 GA
85XU0407A04	#4-7 X 1/4 DRIVE PIN	6.000 EA
LB1073	LABEL, UL/CSA "XP"	1.000 EA
LB5040	INSTRUCTION TAG, AC & DC	1.000 EA
LB1119	WARNING LABEL	1.000 EA
LB1125C01	STD (STOCK) CARTON LABEL BALDOR WITH FLA	4.000 EA
LC0145B01	CONNECTION LABEL	1.000 EA
NP0890XP	UL/CSA, CLI GP-D,INV	1.000 EA
40PA1005	PACKAGING GROUP, 09 STD	1.000 EA

Performance Data at 460V, 60Hz, 15.0HP (Typical performance - Not guaranteed values)

General Characteristics							
Full Load Torque:	45.0 LB-FT			Start Configuration:	DOL		
No-Load Current:	6.95 Amps			Break-Down Torque:	143.0 LB-FT		
Line-line Res. @ 25°C.:	0.577 Ohms A Ph / 0.0 Ohms B Ph			Pull-Up Torque:	75.0 LB-FT		
Temp. Rise @ Rated Load:	47 C			Locked-Rotor Torque:	88.0 LB-FT		
Temp. Rise @ S.F. Load:				Starting Current:	125.0 Amps		
Load Characteristics							
% of Rated Load	25	50	75	100	125	150	S.F.
Power Factor:	49.0	71.0	81.0	86.0	88.0	89.0	87.0
Efficiency:	87.9	92.1	93.0	92.8	92.3	91.5	92.5
Speed:	1792.0	1784.0	1776.0	1766.0	1759.0	1750.0	1762.0
Line Amperes:	7.9	10.5	13.7	17.2	21.0	25.0	19.5

Performance Graph at 460V, 60Hz, 15.0HP Typical performance - Not guaranteed values

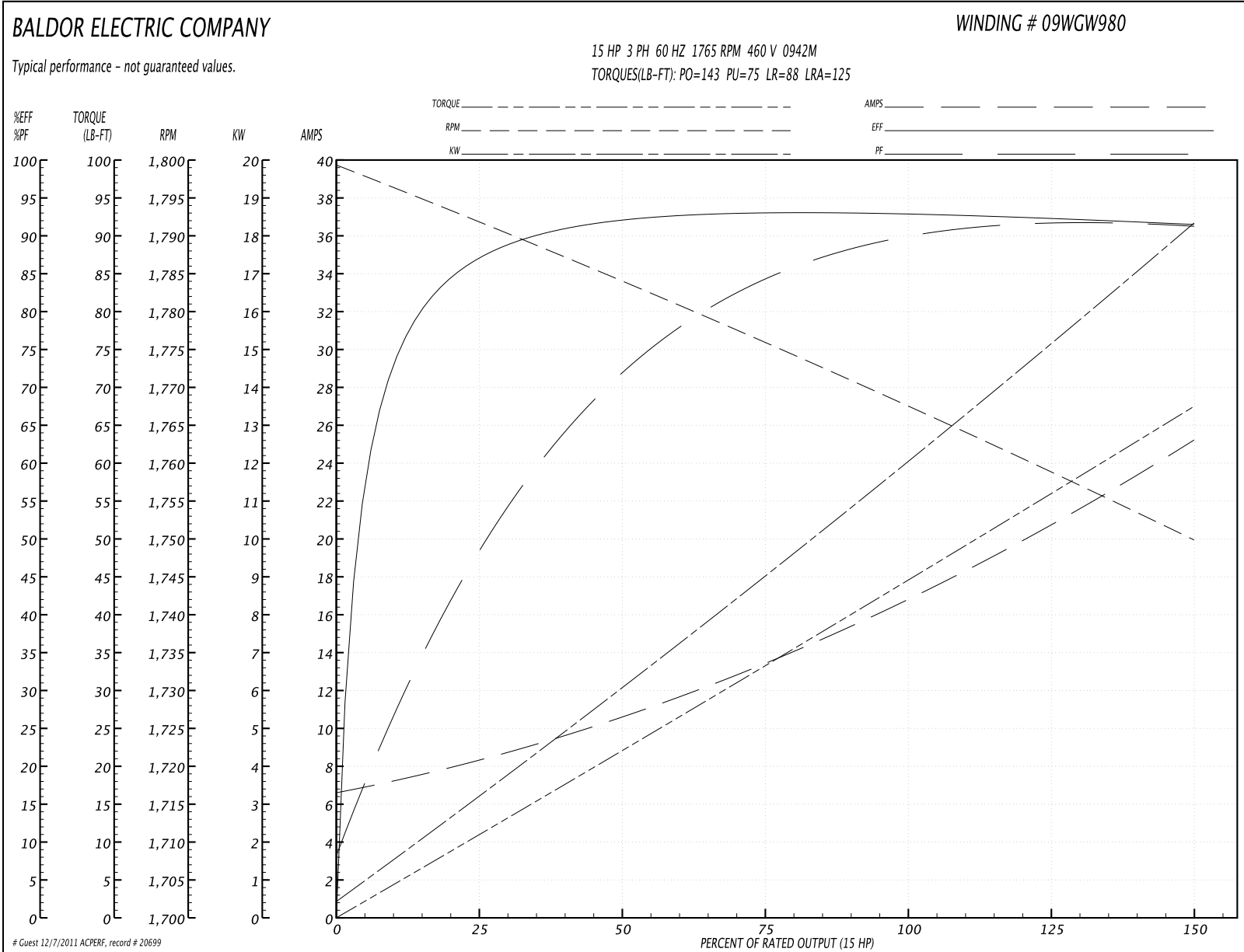

09E963

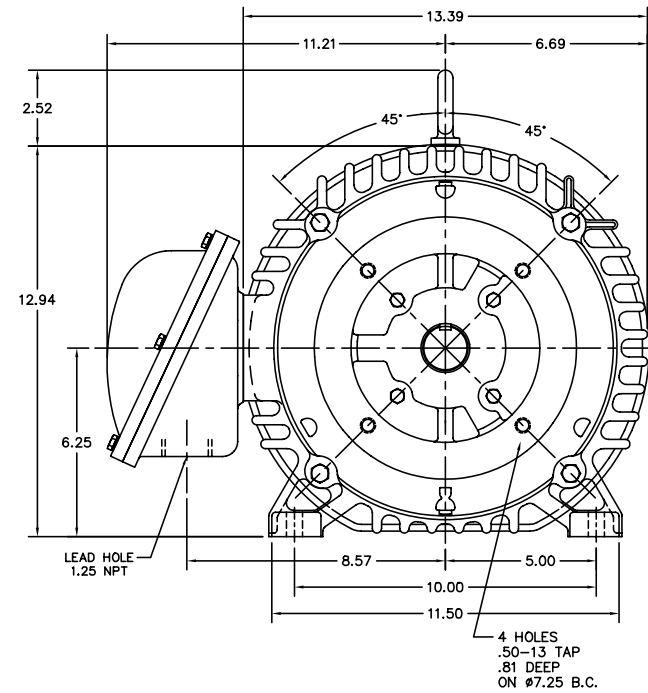
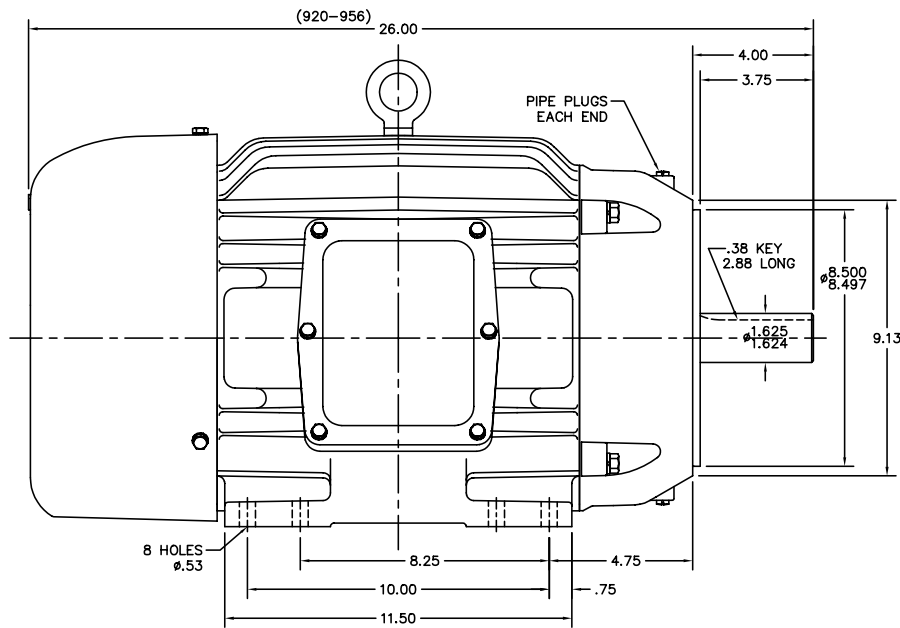

CUST. NAME		CUST. P.O.			REMARKS:		
MODEL	INSUL	AMB	H.P.	MTG	REV:	NEW	
R.P.M.	VOLTS	ENCL	PHASE	FREQ	SCALE:	BY:	MGC
FRAME	TYPE	CERTIFIED BY			FILE:	AAA00055626	REVISED: 06/09/98
					TDR:	0153444	

BALDOR ELECTRIC Co.

HOR XPFC 254-6TC; CL.1,GP.D ONLY; INVERTER DUTY

09E963

CD0005



LOW VOLTAGE
(2Y)



LINE

HIGH VOLTAGE
(1Y)



LINE

NOTES:

1. INTERCHANGE ANY TWO LINE LEADS TO REVERSE ROTATION.
2. OPTIONAL THERMOSTATS ARE PROVIDED WHEN SPECIFIED.
3. ACTUAL NUMBER OF INTERNAL PARALLEL CIRCUITS MAY BE A MULTIPLE OF THOSE SHOWN ABOVE.
4. LEAD COLORS ARE OPTIONAL. LEADS MUST ALWAYS BE NUMBERED AS SHOWN.

REV. DESC: REVISE TO SHOW OPTIONAL COLORS			
REV. LTR: E	BY: JLP	REVISED: 01/19/99 10:15	TDR: 0171435
900000		FILE: AAA00005140	MDL: -
		MTL: -	

BALDOR ELECTRIC Co.

3PH, DV, 9 LEADS

CD0005