

BALDOR® • RELIANCE

Product Information Packet

ELECTRIC MOTOR WHOLESAL.COM

IDXM7062T

40HP,1775RPM,3PH,60HZ,324T,X1260M,XPFC

Part Detail							
Revision:	J	Status:	PRD/A	Change #:		Proprietary:	No
Type:	AC	Prod. Type:	1260M	Elec. Spec:	12WGX277	CD Diagram:	
Enclosure:	XPFC	Mfg Plant:		Mech. Spec:	12M099	Layout:	
Frame:	324T	Mounting:	F1	Poles:	04	Created Date:	
Base:	RG	Rotation:	R	Insulation:	F	Eff. Date:	12-02-2010
Leads:	9#8	Literature:		Elec. Diagram:		Replaced By:	

Nameplate NP0890XP									
NO.		TEMP CODE	T2B						
SPEC.	12M099X277G1	MX RPM	2700						
CAT.NO.	IDXM7062T	INV.TYPE	PWM						
HP	40	C HP FR	60	C HP TO	90				
VOLTS	230/460	CT HZ FROM	30	CT HZ TO	60				
AMPS	92/46	VT HZ FROM	6	VT HZ TO	60				
RPM	1775	DES	B	WK2	7.99	PH	3	CL	F
HZ	60	SER.F.	1.00	NOM.EFF.	94.5	SL HZ	0.8		
MAG CUR	30.4/15.2								
RATING	40C AMB-CONT								
FRAME	324T	CC	010A						
S/N									

Parts List		
Part Number	Description	Quantity
SA109044	SA 12M099X277G1	1.000 EA
RA100551	RA 12M099X277G1	1.000 EA
12CB1001A01	K.O.BOX, MACH X-PROOF; 1.50 NPT HOLE	1.000 EA
10XN3118K16	5/16-18 X 1" GRADE #5, STL, ZINC PLATE	4.000 EA
HW1001A31	LOCKWASHER 5/16, ZINC PLT.591 OD, .319 I	4.000 EA
WD1000B16	KPA-4C BURNDY TERMINAL	1.000 EA
10XN2520K06	1/4-20 X 3/8" HX HD SCREWGRADE 5, ZINC P	1.000 EA
HW1001A25	LOCKWASHER 1/4, ZINC PLT .493 OD, .255 I	1.000 EA
12EP1705A01	ENDPLATE, MACH. 312 - EXPLOSION PROOF 31	1.000 EA
HA3051A03	1/2-13X2.75 BLT GR8 1.75 TO E NC F/S	4.000 EA
HW1001A50	LOCKWASHER 1/2, ZINC PLT,.879 OD, .509 I	4.000 EA
HW5100A13	W4627-047 WVY WSHER	1.000 EA
12EP1706A01	ENDPLATE, MACH. 312 - EXPLOSION PROOF 31	1.000 EA
10XN3118K44	5/16-18 X 2.75" HEX HD, GRADE 5	4.000 EA
HW1001A31	LOCKWASHER 5/16, ZINC PLT.591 OD, .319 I	4.000 EA
HA3051A03	1/2-13X2.75 BLT GR8 1.75 TO E NC F/S	4.000 EA
HW1001A50	LOCKWASHER 1/2, ZINC PLT,.879 OD, .509 I	4.000 EA
12FH1001A01	FAN HOUSING 312 EXPLOSION PROOF MOTORS	1.000 EA
10XN3118K12	5/16-18 X .75 GRADE 5, ZINC PLATED	3.000 EA
HW1001A31	LOCKWASHER 5/16, ZINC PLT.591 OD, .319 I	3.000 EA
12CB1501A01	COND.BOX LID, MACH., X-PROOF, 310,312	1.000 EA
10XN3816K20	3/8-16 X 1.25 HEX HD CAP GRADE 5	6.000 EA
HW1001A38	LOCKWASHER 3/8, ZINC PLT .688 OD, .382 I	6.000 EA
HW2501H33	KEY, 1/2 SQ X 3.875	1.000 EA

Parts List (continued)		
Part Number	Description	Quantity
LB1115	LABEL,LIFTING DEVICE	1.000 EA
HW4500A20	1/8NPT SL PIPE PLUG	2.000 EA
MJ1000A75	GREASE, POLYREX EM EXXON	0.200 LB
HW4500A20	1/8NPT SL PIPE PLUG	2.000 EA
MG1025G05	PAINT 789.201 (WILCO) DARK GRAY METALLIC	0.080 GA
85XU0407A04	#4-7 X 1/4 DRIVE PIN	6.000 EA
LB1073	LABEL, UL/CSA "XP"	1.000 EA
LB5040	INSTRUCTION TAG, AC & DC	1.000 EA
09FN5001B03	EXT FAN ASS'Y W/09FN3001B03	1.000 EA
LB1119	WARNING LABEL	1.000 EA
LB1125C01	STD (STOCK) CARTON LABEL BALDOR WITH FLA	2.000 EA
LC0181	CONNECTION LABEL	1.000 EA
NP0890XP	UL/CSA, CLI GP-D,INV	1.000 EA
14PA1000	PACKAGING 314 GROUP COMBINED PRINT	1.000 EA

Performance Data at 460V, 60Hz, 40.0HP (Typical performance - Not guaranteed values)

General Characteristics							
Full Load Torque:	118.0 LB-FT			Start Configuration:	DOL		
No-Load Current:	16.8 Amps			Break-Down Torque:	357.0 LB-FT		
Line-line Res. @ 25°C.:	0.146 Ohms A Ph / 0.0 Ohms B Ph			Pull-Up Torque:	167.0 LB-FT		
Temp. Rise @ Rated Load:	51 C			Locked-Rotor Torque:	178.0 LB-FT		
Temp. Rise @ S.F. Load:				Starting Current:	320.0 Amps		
Load Characteristics							
% of Rated Load	25	50	75	100	125	150	S.F.
Power Factor:	52.0	73.0	81.0	84.0	86.0	86.0	85.0
Efficiency:	90.6	93.9	94.6	94.6	94.1	93.5	94.3
Speed:	1795.0	1790.0	1785.0	1780.0	1774.0	1767.0	1776.0
Line Amperes:	20.4	28.0	37.1	46.9	58.1	69.2	53.78

Performance Graph at 460V, 60Hz, 40.0HP Typical performance - Not guaranteed values

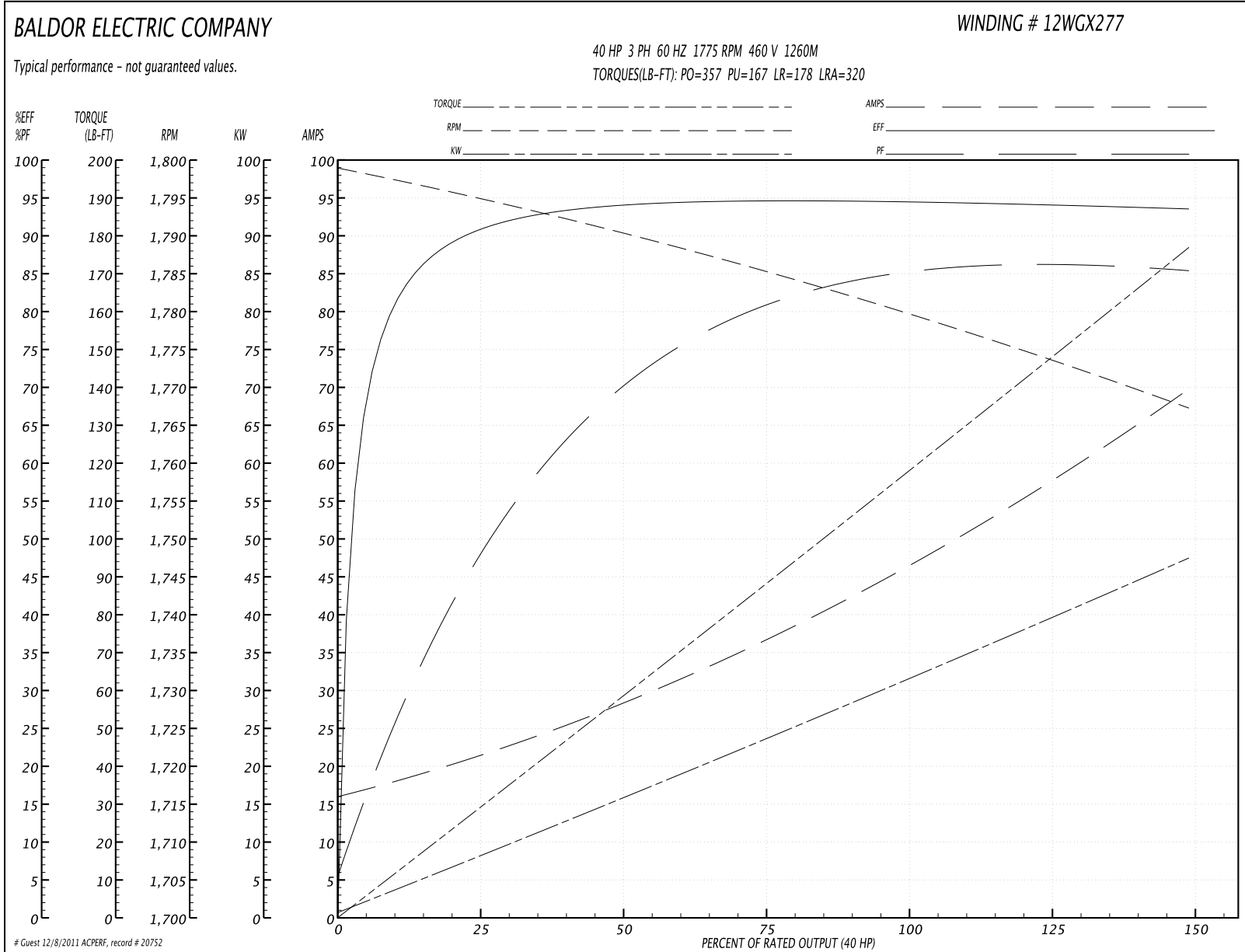

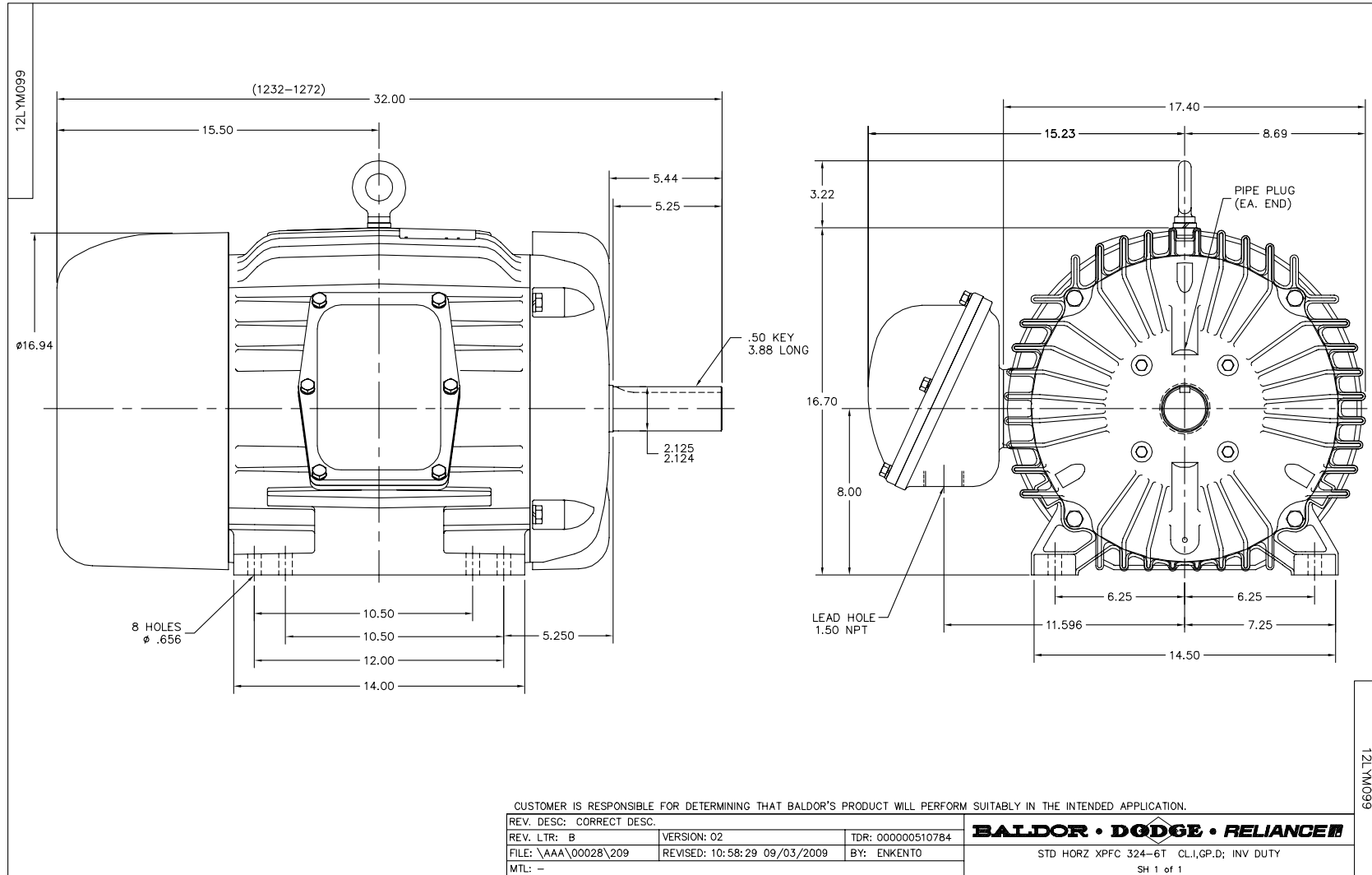

12LYM099

CD0180



LOW VOLTAGE
(2D)

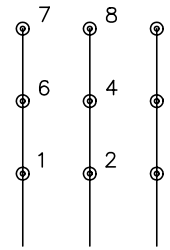

HIGH VOLTAGE
(1D)

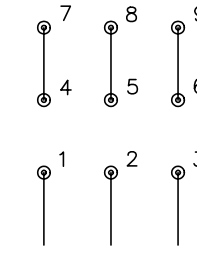

NOTES:

1. INTERCHANGE ANY TWO LINE LEADS TO REVERSE ROTATION.
2. OPTIONAL THERMOSTATS ARE PROVIDED WHEN SPECIFIED.
3. ACTUAL NUMBER OF INTERNAL PARALLEL CIRCUITS MAY BE A MULTIPLE OF THOSE SHOWN ABOVE.
4. LEAD COLORS ARE OPTIONAL. LEADS MUST ALWAYS BE NUMBERED AS SHOWN.

REV. DESC: REVISE TO SHOW OPTIONAL COLORS			
REV. LTR: C	BY: JLP	REVISED: 01/21/99 2:28	TDR: 0171435
0810D0		FILE: AAA00005148	MDL: -
		MTL: -	

BALDOR ELECTRIC Co.

3PH, DV, 9 LEADS, DELTA CONNECTION

CD0180