

BALDOR® • RELIANCE

Product Information Packet

ELECTRIC MOTOR WHOLESAL.COM

JMM2534T

30HP,3510RPM,3PH,60HZ,284JM,3936M,OPSB

Part Detail							
Revision:	K	Status:	PRD/A	Change #:		Proprietary:	No
Type:	AC	Prod. Type:	3936M	Elec. Spec:	39WG883	CD Diagram:	
Enclosure:	OPSB	Mfg Plant:		Mech. Spec:	39N090	Layout:	
Frame:	284JM	Mounting:	F1	Poles:	02	Created Date:	
Base:	RG	Rotation:	R	Insulation:	B	Eff. Date:	07-28-2011
Leads:	9#10	Literature:		Elec. Diagram:		Replaced By:	

Nameplate NP1256L									
CAT.NO.	JMM2534T								
SPEC.	39N090W883H1								
HP	30								
VOLTS	230/460								
AMP	70/35								
RPM	3510								
FRAME	284JM	HZ			60	PH	3		
SER.F.	1.15	CODE			G	DES	B	CLASS	B
NEMA-NOM-EFF	91	PF			89				
RATING	40C AMB-CONT								
CC	010A	USABLE AT 208V			75				
DE	6312	ODE			6208				
ENCL	OPSB	SN							

Parts List		
Part Number	Description	Quantity
SA057042	SA 39N090W883H1	1.000 EA
RA051563	RA 39N090W883H1	1.000 EA
S/P101-000-003	EPACT PROC-ZK 280FR & UP,LARGE KOBX,POLY	1.000 EA
HW3201A01	1/2-13 EYEBOLT	1.000 EA
09CB2800A03	ADAPTER MACH FOR 10CB3000	1.000 EA
19XW3118A08	.31-18 X .50 HEX WASHER HEAD TAPTITE II	2.000 EA
HW1001A31	LOCKWASHER 5/16, ZINC PLT.591 OD, .319 I	2.000 EA
10CB3000SP	STD KO BOX MODEL 310,312,314 MTRS W/2.00	1.000 EA
19XW3118A12	.31-18 X .75 HEX WASHER HEAD TAPTITE II	4.000 EA
HW1001A31	LOCKWASHER 5/16, ZINC PLT.591 OD, .319 I	4.000 EA
WD1000B16	KPA-4C BURNDY TERMINAL	1.000 EA
51XF2520A08	SCREW, HEX SER SLT HD, ZN 1/4-20 X .50 L	1.000 EA
39EP3200A01SP	FR/PU ENDPLATE, MACH	1.000 EA
HA4051A00	PLASTIC CAP FOR GREASE FITTING	1.000 EA
HA1221	RODENT SCREEN 39EP1404	4.000 EA
HW3207A04	CABLE TIE 5 5/8 X .14" BLACK	8.000 EA
HA1101A01	RODENT SCREEN, 39 MTR	1.000 EA
51XW1032A06	10-32 X .38, TAPTITE II, HEX WSHR SLTD S	4.000 EA
HW5100A08	W3118-035 WVY WSHR (WB)	1.000 EA
10XN3118K40	5/16-18 X 2.50" HEX HD, GRADE 5	4.000 EA
HW1001A31	LOCKWASHER 5/16, ZINC PLT.591 OD, .319 I	4.000 EA
39EP1404A03	FACE MTD.EP MACH. 284-6 OPEN	1.000 EA
HA4051A00	PLASTIC CAP FOR GREASE FITTING	1.000 EA
HW4600B41	V-RING SLINGER 2.125 X 2.880 X 0.280	1.000 EA

Parts List (continued)		
Part Number	Description	Quantity
XY3816A12	3/8-16 FINISHED NUT	4.000 EA
10CB3500SP	CONDUIT BOX LID, CAST	1.000 EA
51XW2520A12	.25-20 X .75, TAPTITE II, HEX WSHR SLTD	4.000 EA
HW2501E22	KEY, 1/4 SQ X 2.500	1.000 EA
LB1115	LABEL,LIFTING DEVICE	1.000 EA
HW4500A03	GREASE FITTING, .125 NPT 1610(ALEMITE) 8	1.000 EA
HW4500A20	1/8NPT SL PIPE PLUG	1.000 EA
MJ1000A75	GREASE, POLYREX EM EXXON	0.030 LB
HW4500A03	GREASE FITTING, .125 NPT 1610(ALEMITE) 8	1.000 EA
HW4500A20	1/8NPT SL PIPE PLUG	1.000 EA
MG1000G27	PAINT- S9282E CHARCOAL GREY 55 GALLONS	0.050 GA
85XU0407A04	#4-7 X 1/4 DRIVE PIN	2.000 EA
39AD2002B01	BAFFLE PLATE 39 OPEN, SLOTTED BAND MTRS	2.000 EA
HA3113A04	3/8-16 X 15.50 THRUBOLT	4.000 EA
LB1119	WARNING LABEL	1.000 EA
LC0181	CONNECTION LABEL	1.000 EA
LB1125C04	STD-E (STOCK CTN LABEL STD-E WITH FLAG)	4.000 EA
NP1256L	ALUM, UL CSA CC, W/O THERMAL, LASER	1.000 EA
40PA1000	PACKAGING GROUP	1.000 EA

Performance Data at 460V, 60Hz, 30.0HP (Typical performance - Not guaranteed values)

General Characteristics							
Full Load Torque:	44.9 LB-FT			Start Configuration:	DOL		
No-Load Current:	10.3 Amps			Break-Down Torque:	156.0 LB-FT		
Line-line Res. @ 25°C.:	0.393 Ohms A Ph / 0.0 Ohms B Ph			Pull-Up Torque:	47.6 LB-FT		
Temp. Rise @ Rated Load:	37 C			Locked-Rotor Torque:	67.2 LB-FT		
Temp. Rise @ S.F. Load:	51 C			Starting Current:	214.0 Amps		
Load Characteristics							
% of Rated Load	25	50	75	100	125	150	S.F.
Power Factor:	60.0	80.0	87.0	89.0	90.0	90.0	90.0
Efficiency:	89.4	92.2	92.3	91.4	90.2	88.5	90.7
Speed:	3578.0	3556.0	3533.0	3508.0	3481.0	3450.0	3492.0
Line Amperes:	13.03	19.0	26.36	34.4	43.2	53.1	39.7

Performance Graph at 460V, 60Hz, 30.0HP Typical performance - Not guaranteed values

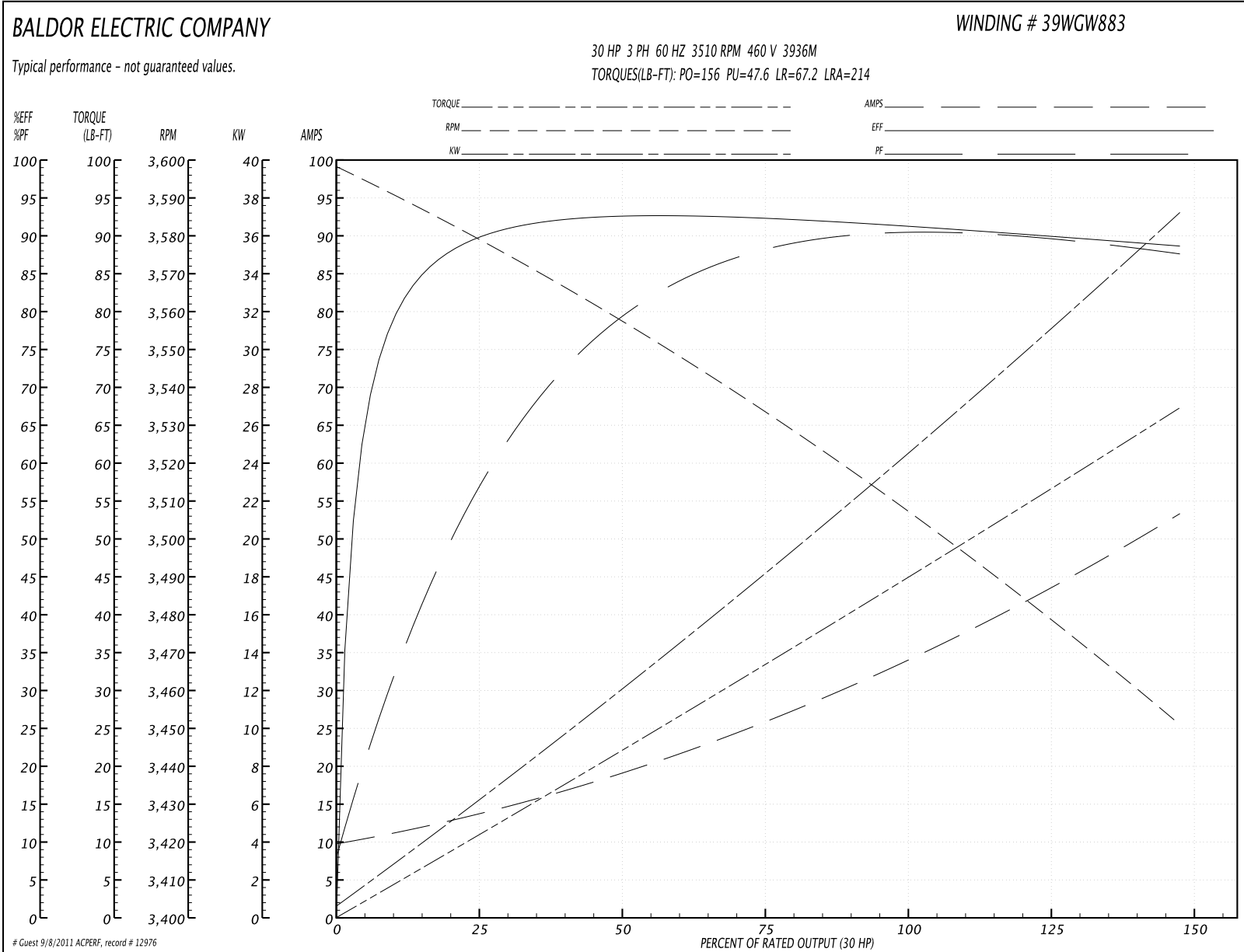

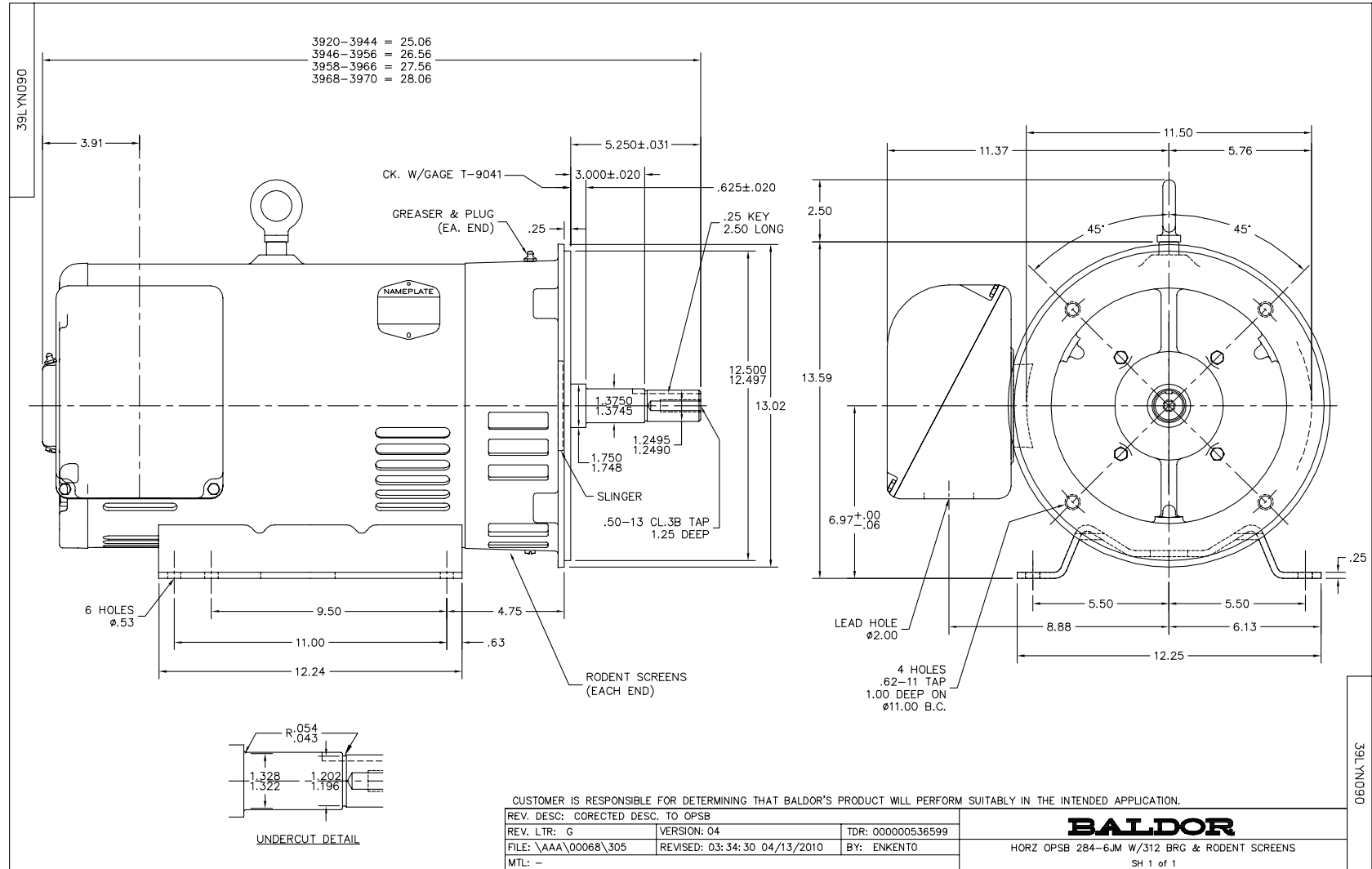

CD0180

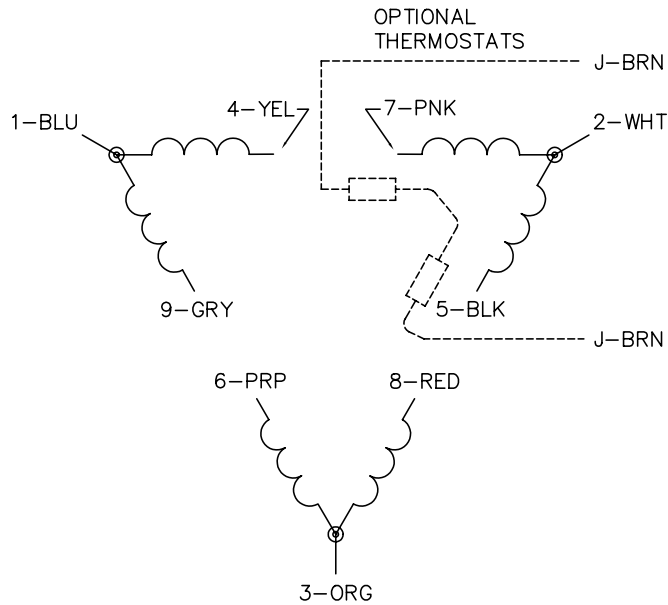

LOW VOLTAGE
(2D)

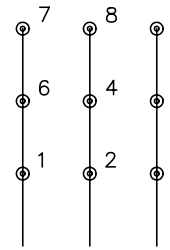

LINE

HIGH VOLTAGE
(1D)

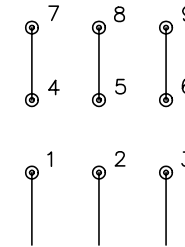

LINE

NOTES:

1. INTERCHANGE ANY TWO LINE LEADS TO REVERSE ROTATION.
2. OPTIONAL THERMOSTATS ARE PROVIDED WHEN SPECIFIED.
3. ACTUAL NUMBER OF INTERNAL PARALLEL CIRCUITS MAY BE A MULTIPLE OF THOSE SHOWN ABOVE.
4. LEAD COLORS ARE OPTIONAL. LEADS MUST ALWAYS BE NUMBERED AS SHOWN.

REV. DESC: REVISE TO SHOW OPTIONAL COLORS			
REV. LTR: C	BY: JLP	REVISED: 01/21/99 2:28	TDR: 0171435
0810D0		FILE: AAA00005148	MDL: -
		MTL: -	

BALDOR ELECTRIC Co.

3PH, DV, 9 LEADS, DELTA CONNECTION

CD0180