

# **BALDOR® • RELIANCE**

**Product Information Packet**

**ELECTRIC MOTOR WHOLESAL.COM**

**M2523**

**15HP,1765RPM,3PH,60HZ,284U,3934M,OPSB,F1**

Part Detail							
Revision:	-	Status:	PRD/A	Change #:		Proprietary:	No
Type:	AC	Prod. Type:	3934M	Elec. Spec:	39WG107	CD Diagram:	
Enclosure:	OPSB	Mfg Plant:		Mech. Spec:	39L57	Layout:	
Frame:	284U	Mounting:	F1	Poles:	04	Created Date:	05-10-2010
Base:	RG	Rotation:	R	Insulation:	B	Eff. Date:	05-14-2010
Leads:	9#12	Literature:		Elec. Diagram:		Replaced By:	

**Nameplate NP1256L**

CAT.NO.	M2523						
SPEC.	39L057X107H1						
HP	15						
VOLTS	230/460						
AMP	36/18						
RPM	1765						
FRAME	284U	HZ	60	PH	3		
SER.F.	1.15	CODE	G	DES	B	CLASS	B
NEMA-NOM-EFF	91	PF	85				
RATING	40C AMB-CONT						
CC	010A	USABLE AT 208V					
DE	6311	ODE	6208				
ENCL	OPSB	SN					

Parts List		
Part Number	Description	Quantity
SA194631	SA 39L057X107H1	1.000 EA
RA182217	RA 39L057X107H1	1.000 EA
S/P101-000-003	EPACT PROC-ZK 280FR & UP,LARGE KOBX,POLY	1.000 EA
HA6361A01	LIFTING LUG FOR 37, 39 & 40 FRAME (AUTOP	2.000 EA
09CB2800A03	ADAPTER MACH FOR 10CB3000	1.000 EA
84XN3118J08	5/16-18 X 1/2 SOC HD CAP SCREW	2.000 EA
HW1001A31	LOCKWASHER 5/16, ZINC PLT.591 OD, .319 I	2.000 EA
10CB3000SP	STD KO BOX MODEL 310,312,314 MTRS W/2.00	1.000 EA
19XW3118A12	.31-18 X .75 HEX WASHER HEAD TAPTITE II	4.000 EA
HW1001A31	LOCKWASHER 5/16, ZINC PLT.591 OD, .319 I	4.000 EA
WD1000B16	KPA-4C BURNDY TERMINAL	1.000 EA
51XF2520A08	SCREW, HEX SER SLT HD, ZN 1/4-20 X .50 L	1.000 EA
39EP3200A01SP	FR/PU ENDPLATE, MACH	1.000 EA
HW5100A08	W3118-035 WVY WSHR (WB)	1.000 EA
39EP3202A01	ENDPLATE MACH	1.000 EA
XY3816A12	3/8-16 FINISHED NUT	8.000 EA
10CB3500SP	CONDUIT BOX LID, CAST	1.000 EA
51XW2520A12	.25-20 X .75, TAPTITE II, HEX WSHR SLTD	4.000 EA
HW2501G32	KEY, 3/8 SQ X 3.750	1.000 EA
LB1115	LABEL,LIFTING DEVICE	1.000 EA
LB5040	INSTRUCTION TAG, AC & DC	1.000 EA
HA4051A00	PLASTIC CAP FOR GREASE FITTING	1.000 EA
HW4500A03	GREASE FITTING, .125 NPT 1610(ALEMITE) 8	1.000 EA
HW4500A20	1/8NPT SL PIPE PLUG	1.000 EA

Parts List (continued)		
Part Number	Description	Quantity
MJ1000A75	GREASE, POLYREX EM EXXON	0.030 LB
HA4051A00	PLASTIC CAP FOR GREASE FITTING	1.000 EA
HW4500A03	GREASE FITTING, .125 NPT 1610(ALEMITE) 8	1.000 EA
HW4500A20	1/8NPT SL PIPE PLUG	1.000 EA
HA3154A03	STUD, 3/8-16 X 17.75	4.000 EA
MG1000G27	PAINT- S9282E CHARCOAL GREY 55 GALLONS	0.035 GA
85XU0407A04	#4-7 X 1/4 DRIVE PIN	2.000 EA
39AD2002B01	BAFFLE PLATE 39 OPEN, SLOTTED BAND MTRS	1.000 EA
39AD2002B01	BAFFLE PLATE 39 OPEN, SLOTTED BAND MTRS	1.000 EA
LB1119	WARNING LABEL	1.000 EA
LB1125C04	STD-E (STOCK CTN LABEL STD-E WITH FLAG)	4.000 EA
LC0181	CONNECTION LABEL	1.000 EA
NP1256L	ALUM, UL CSA CC, W/O THERMAL, LASER	1.000 EA
40PA1000	PACKAGING GROUP	1.000 EA

Accessories		
Part Number	Description	Multiplier
39-1403	C FACE KIT	A8

39LY1057

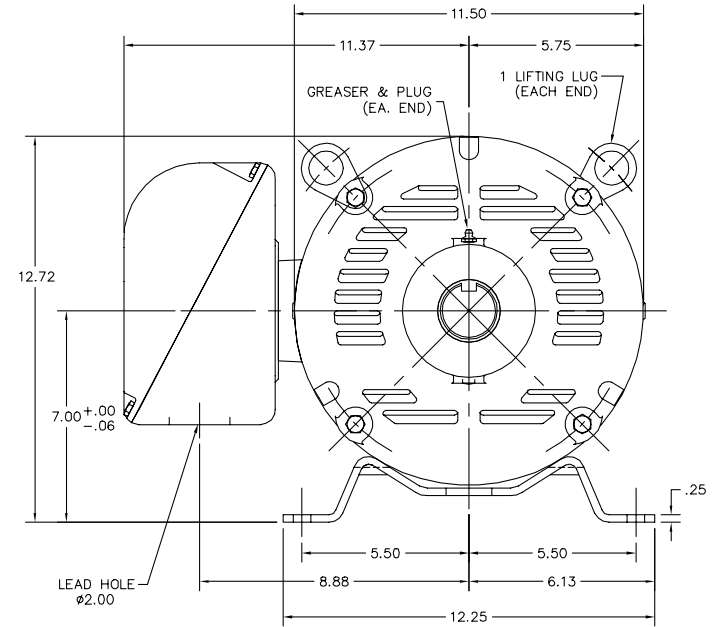
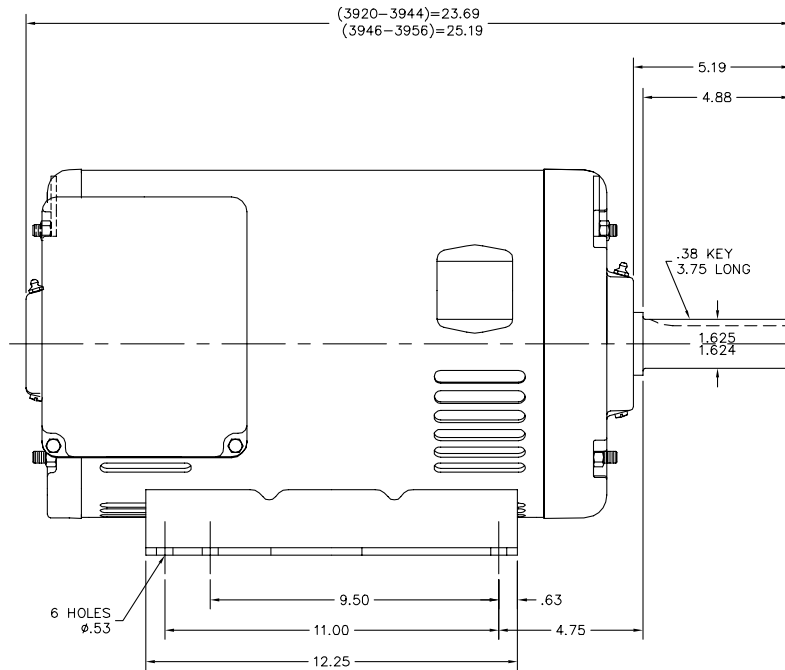

CUSTOMER IS RESPONSIBLE FOR DETERMINING THAT MOTOR PERFORMANCE IS SUITABLE IN THE APPLICATION.

REV. DESC: FIXED DESC. TO "OPSB"		
REV. LTR: B	VERSION: 01	TDR: 000000447737
FILE: \AAA\00012\532	REVISED: 11:43:05 10/31/2007	BY: ENKENTO
MTL: -		

**Baldor • Dodge • Reliance**

STD HOR OPSB 284-6U

39LY1057

CD0180

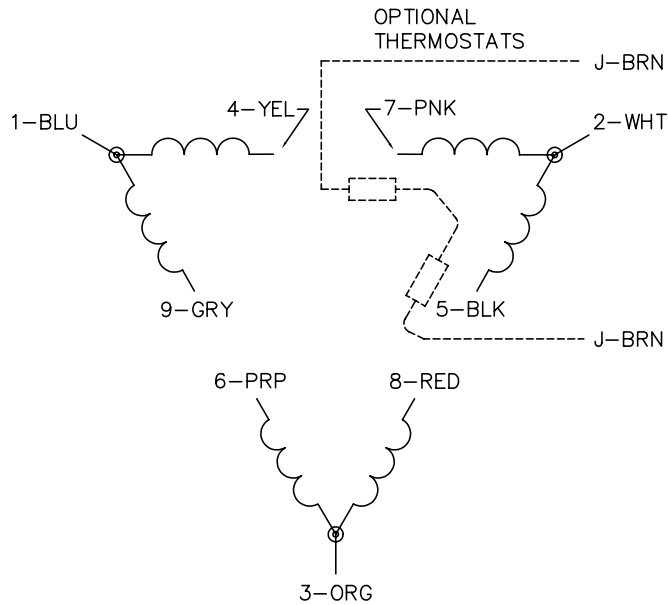

LOW VOLTAGE  
(2D)

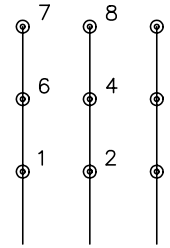

HIGH VOLTAGE  
(1D)

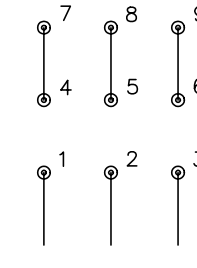

NOTES:

1. INTERCHANGE ANY TWO LINE LEADS TO REVERSE ROTATION.
2. OPTIONAL THERMOSTATS ARE PROVIDED WHEN SPECIFIED.
3. ACTUAL NUMBER OF INTERNAL PARALLEL CIRCUITS MAY BE A MULTIPLE OF THOSE SHOWN ABOVE.
4. LEAD COLORS ARE OPTIONAL. LEADS MUST ALWAYS BE NUMBERED AS SHOWN.

REV. DESC: REVISE TO SHOW OPTIONAL COLORS			
REV. LTR: C	BY: JLP	REVISED: 01/21/99 2:28	TDR: 0171435
0810D0		FILE: AAA00005148	MDL: -
		MTL: -	

**BALDOR ELECTRIC Co.**

3PH, DV, 9 LEADS, DELTA CONNECTION

CD0180