

BALDOR® • RELIANCE

Product Information Packet

ELECTRIC MOTOR WHOLESAL.COM

M2535

30HP,1775RPM,3PH,60HZ,326U,4046M,OPSB,F1

Part Detail							
Revision:	H	Status:	PRD/A	Change #:		Proprietary:	No
Type:	AC	Prod. Type:	4046M	Elec. Spec:	40WGW350	CD Diagram:	
Enclosure:	OPSB	Mfg Plant:		Mech. Spec:	40H08	Layout:	
Frame:	326U	Mounting:	F1	Poles:	04	Created Date:	
Base:	RG	Rotation:	R	Insulation:	B	Eff. Date:	02-24-2010
Leads:	9#10	Literature:		Elec. Diagram:		Replaced By:	

Nameplate NP1256L

CAT.NO.	M2535						
SPEC.	40H008W350H1						
HP	30						
VOLTS	230/460						
AMP	74/37						
RPM	1775						
FRAME	326U	HZ	60	PH	3		
SER.F.	1.15	CODE	H	DES	B	CLASS	B
NEMA-NOM-EFF	92.4	PF	82				
RATING	40C AMB-CONT						
CC		USABLE AT 208V					
DE	6312	ODE	6309				
ENCL	OPSB	SN					

Parts List		
Part Number	Description	Quantity
SA062436	SA 40H008W350H1	1.000 EA
RA056684	RA 40H008W350H1	1.000 EA
S/P101-000-003	EPACT PROC-ZK 280FR & UP,LARGE KOBX,POLY	1.000 EA
HA6361A01	LIFTING LUG FOR 37, 39 & 40 FRAME (AUTOP	2.000 EA
HA6017A01	CAST ADAPTOR	1.000 EA
19XW3118A12	.31-18 X .75 HEX WASHER HEAD TAPTITE II	2.000 EA
HW1001A31	LOCKWASHER 5/16, ZINC PLT.591 OD, .319 I	2.000 EA
10CB3001	CONDUIT BOX CAST W/2.500 LEAD HOLE	1.000 EA
19XW3118A12	.31-18 X .75 HEX WASHER HEAD TAPTITE II	4.000 EA
HW1001A31	LOCKWASHER 5/16, ZINC PLT.591 OD, .319 I	4.000 EA
WD1000B16	KPA-4C BURNDY TERMINAL	1.000 EA
51XF2520A08	SCREW, HEX SER SLT HD, ZN 1/4-20 X .50 L	1.000 EA
40EP3200A02	STD FREP OPEN 309 BRG	1.000 EA
HA4051A00	PLASTIC CAP FOR GREASE FITTING	1.000 EA
HW5100A11	W3917-042 WVY WSHR (WB)	1.000 EA
40EP3201A01	PU ENDPLATE, MACH - OPEN - FOR 312 BRG	1.000 EA
HA4051A00	PLASTIC CAP FOR GREASE FITTING	1.000 EA
HA3154A04	THRUBOLT STUD 3/8-16 X 18.750	4.000 EA
XY3816A12	3/8-16 FINISHED NUT	8.000 EA
10CB3500SP	CONDUIT BOX LID, CAST	1.000 EA
51XW2520A12	.25-20 X .75, TAPTITE II, HEX WSHR SLTD	4.000 EA
HW2501H36	KEY, 1/2 SQ X 4.250	1.000 EA
LB1115	LABEL,LIFTING DEVICE	1.000 EA
HW4500A03	GREASE FITTING, .125 NPT 1610(ALEMITE) 8	1.000 EA

Parts List (continued)		
Part Number	Description	Quantity
HW4500A20	1/8NPT SL PIPE PLUG	1.000 EA
MJ1000A75	GREASE, POLYREX EM EXXON	0.050 LB
HW4500A03	GREASE FITTING, .125 NPT 1610(ALEMITE) 8	1.000 EA
HW4500A20	1/8NPT SL PIPE PLUG	1.000 EA
MG1000G27	PAINT- S9282E CHARCOAL GREY 55 GALLONS	0.070 GA
85XU0407A04	#4-7 X 1/4 DRIVE PIN	2.000 EA
40AD2002B01	LEXAN BAFFLE 40 FR OPEN	2.000 EA
LC0181	CONNECTION LABEL	1.000 EA
LB1119	WARNING LABEL	1.000 EA
LB1125C04	STD-E (STOCK CTN LABEL STD-E WITH FLAG)	4.000 EA
LB5040	INSTRUCTION TAG, AC & DC	1.000 EA
NP1256L	ALUM, UL CSA CC, W/O THERMAL, LASER	1.000 EA
42PA1000	PACKAGING GROUP 42 FRAME PK1024A06	1.000 EA

Accessories		
Part Number	Description	Multiplier
40-1401	C FACE KIT 40/324-6UC TC 6312 BRG	A8

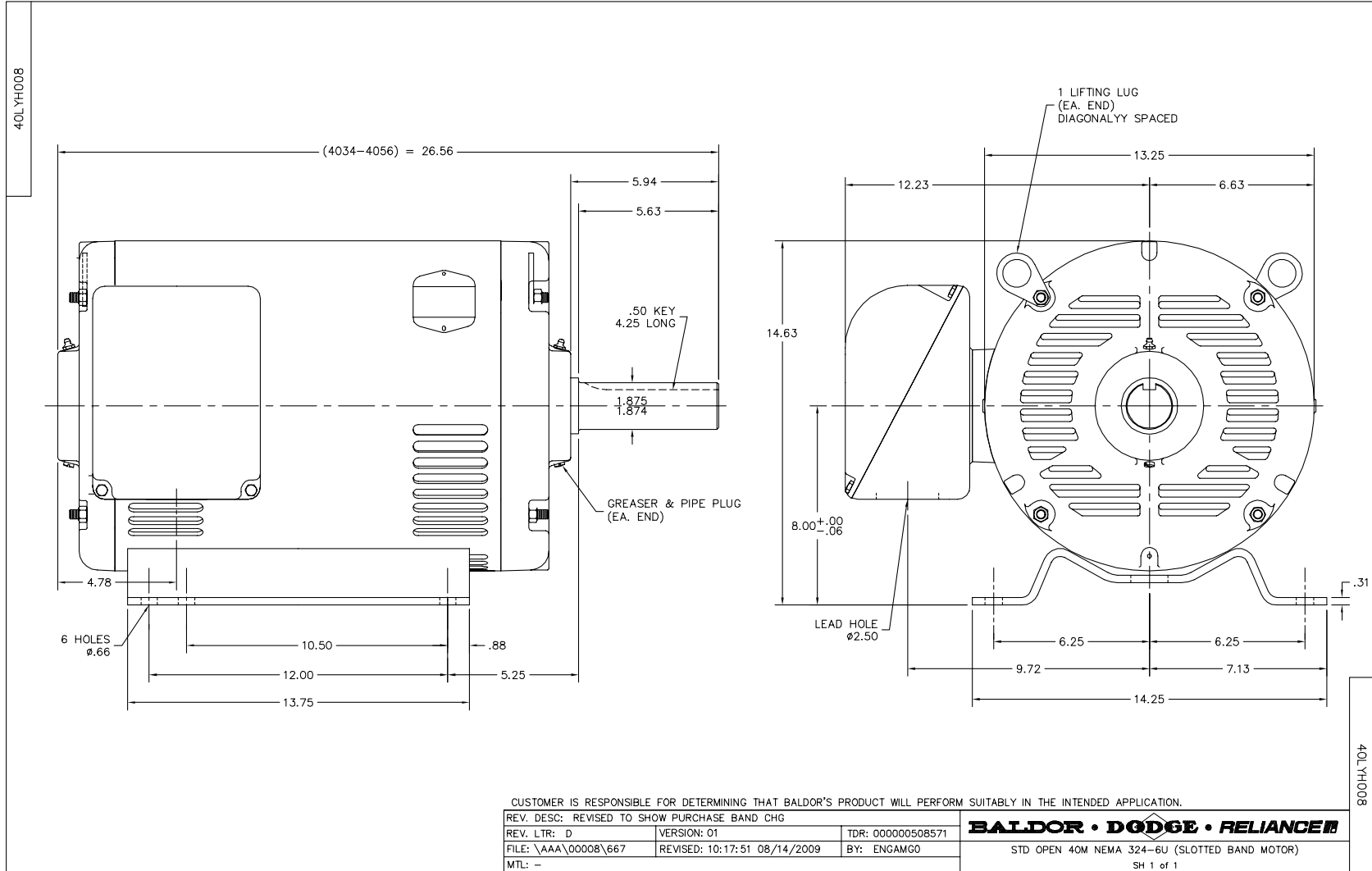

CD0180

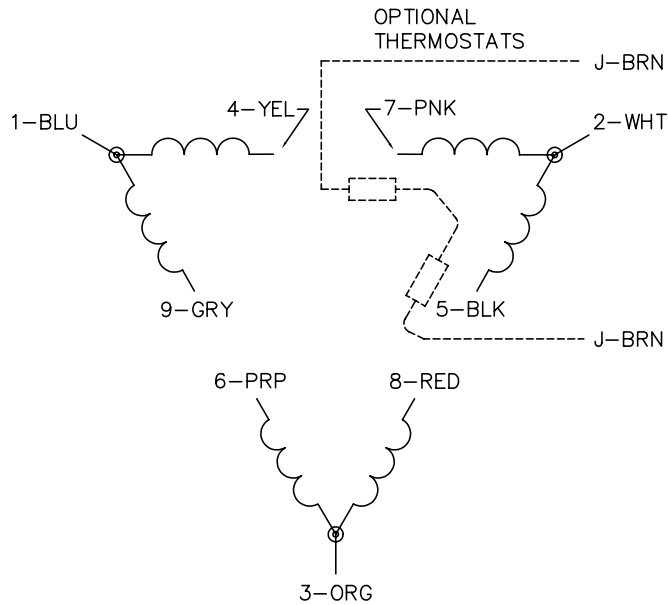

LOW VOLTAGE
(2D)

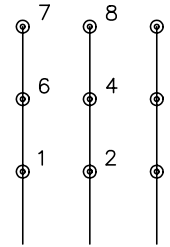

LINE

HIGH VOLTAGE
(1D)

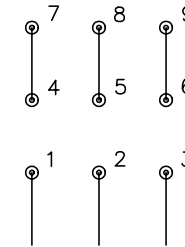

LINE

NOTES:

1. INTERCHANGE ANY TWO LINE LEADS TO REVERSE ROTATION.
2. OPTIONAL THERMOSTATS ARE PROVIDED WHEN SPECIFIED.
3. ACTUAL NUMBER OF INTERNAL PARALLEL CIRCUITS MAY BE A MULTIPLE OF THOSE SHOWN ABOVE.
4. LEAD COLORS ARE OPTIONAL. LEADS MUST ALWAYS BE NUMBERED AS SHOWN.

REV. DESC: REVISE TO SHOW OPTIONAL COLORS			
REV. LTR: C	BY: JLP	REVISED: 01/21/99 2:28	TDR: 0171435
0810D0		FILE: AAA00005148	MDL: -
		MTL: -	

BALDOR ELECTRIC Co.

3PH, DV, 9 LEADS, DELTA CONNECTION

CD0180