

BALDOR® • RELIANCE

Product Information Packet

ELECTRIC MOTOR WHOLESAL.COM

M3605

1.5HP,3450RPM,3PH,60HZ,182,3520M,TEFC,F1

Part Detail							
Revision:	D	Status:	PRD/A	Change #:		Proprietary:	No
Type:	AC	Prod. Type:	3520M	Elec. Spec:	35WGS253	CD Diagram:	
Enclosure:	TEFC	Mfg Plant:		Mech. Spec:	35L108	Layout:	
Frame:	182	Mounting:	F1	Poles:	02	Created Date:	04-30-2010
Base:	RG	Rotation:	R	Insulation:	B	Eff. Date:	07-18-2011
Leads:	9#18	Literature:		Elec. Diagram:		Replaced By:	

Nameplate NP1256L

CAT.NO.	M3605						
SPEC.	35L108S253H1						
HP	1.5						
VOLTS	208-230/460						
AMP	4.3-4.2/2.1						
RPM	3450						
FRAME	182	HZ	60	PH	3		
SER.F.	1.15	CODE	L	DES	B	CLASS	B
NEMA-NOM-EFF	82.5	PF	85				
RATING	40C AMB-CONT						
CC	010A	USABLE AT 208V	4.3				
DE	6206	ODE	6203				
ENCL	TEFC	SN					

Parts List		
Part Number	Description	Quantity
SA194299	SA 35L108S253H1	1.000 EA
RA181887	RA 35L108S253H1	1.000 EA
34FN3002B01	EXTERNAL FAN, PLASTIC, .637/.639 HUB W/	1.000 EA
S/P101-000-000	EPACT PROCEDURES-FS PLANT-POLYREX EM, NO	1.000 EA
NS2512A01	INSULATOR, CONDUIT BOX X	1.000 EA
35CB3009	35 CB CASTING W/1.09 DIA. LEAD HOLE @ 6:	1.000 EA
36GS1000SP	GASKET-CONDUIT BOX, .06 THICK #SV-330 LE	1.000 EA
51XB1016A07	10-16 X 7/16 HXWSSLD SERTYB	2.000 EA
11XW1032G06	10-32 X .38, TAPTITE II, HEX WSHR SLTD U	1.000 EA
HW3001B01	003SS CUP WASHER, FOR #8 SCREW	1.000 EA
35EP3100M01	FREP TEFC 203 BRG W/GRSR (RAISED FH PADS	1.000 EA
HW4500A01	1641B(ALEMITE)400 UNIV, GREASE FITT	1.000 EA
HW5100A03SP	WAVY WASHER (W1543-017)	1.000 EA
35EP3113A01	PU ENDPLATE, MACH W/206 BRG	1.000 EA
HW4500A01	1641B(ALEMITE)400 UNIV, GREASE FITT	1.000 EA
XY1032A02	10-32 HEX NUT DIRECTIONAL SERRATION	4.000 EA
51XB1214A16	12-14X1.00 HXWSSLD SERTYB	1.000 EA
35FH4005A84SP	IEC FH W/GRSR, NO DIMPLES W/AUTOPHERETIC	1.000 EA
51XW1032A06	10-32 X .38, TAPTITE II, HEX WSHR SLTD S	3.000 EA
35CB4521	35 LIPPED CB LID (GALV & PHOSPH)	1.000 EA
35GS1030	35 GS FOR CB LID - LEXIDE	1.000 EA
51XW0832A07	8-32 X .44, TAPTITE II, HEX WSHR SLTD SE	4.000 EA
HW2501D13SP	KEY, 3/16 SQ X 1.375	1.000 EA
HA7000A01	KEY RETAINER 7/8" DIA SHAFT	1.000 EA

Parts List (continued)		
Part Number	Description	Quantity
85XU0407S04	4X1/4 U DRIVE PIN STAINLESS	2.000 EA
MJ1000A75	GREASE, POLYREX EM EXXON	0.050 LB
MG1000G27	PAINT- S9282E CHARCOAL GREY	0.017 GA
HA3100A20	THRUBOLT 10-32 X 9.812	4.000 EA
LB1125C04	STD-E (STOCK CTN LABEL STD-E WITH FLAG)	1.000 EA
LC0005E01	CONN.DIA./WARNING LABEL (LC0005/LB1119)	1.000 EA
NP1256L	ALUM, UL CSA CC, W/O THERMAL, LASER	1.000 EA
35PA1066	PACKING GROUP COMBINED PRINT	1.000 EA
LB5040	INSTRUCTION TAG, AC & DC	1.000 EA

Performance Data at 460V, 60Hz, 1.5HP (Typical performance - Not guaranteed values)
General Characteristics

Full Load Torque:	2.2 LB-FT	Start Configuration:	DOL
No-Load Current:	0.8 Amps	Break-Down Torque:	9.4 LB-FT
Line-line Res. @ 25°C.:	11.6 Ohms A Ph / 0.0 Ohms B Ph	Pull-Up Torque:	6.1 LB-FT
Temp. Rise @ Rated Load:	42 C	Locked-Rotor Torque:	7.7 LB-FT
Temp. Rise @ S.F. Load:	49 C	Starting Current:	18.0 Amps

Load Characteristics

% of Rated Load	25	50	75	100	125	150	S.F.
Power Factor:	58.0	76.0	85.0	89.0	92.0	94.0	0.0
Efficiency:	71.6	80.1	82.6	83.0	82.5	81.3	0.0
Speed:	3566.0	3540.0	3513.0	3481.0	3449.0	3413.0	0.0
Line Amperes:	1.0	1.2	1.6	2.0	2.4	2.8	2.2

Performance Graph at 460V, 60Hz, 1.5HP Typical performance - Not guaranteed values

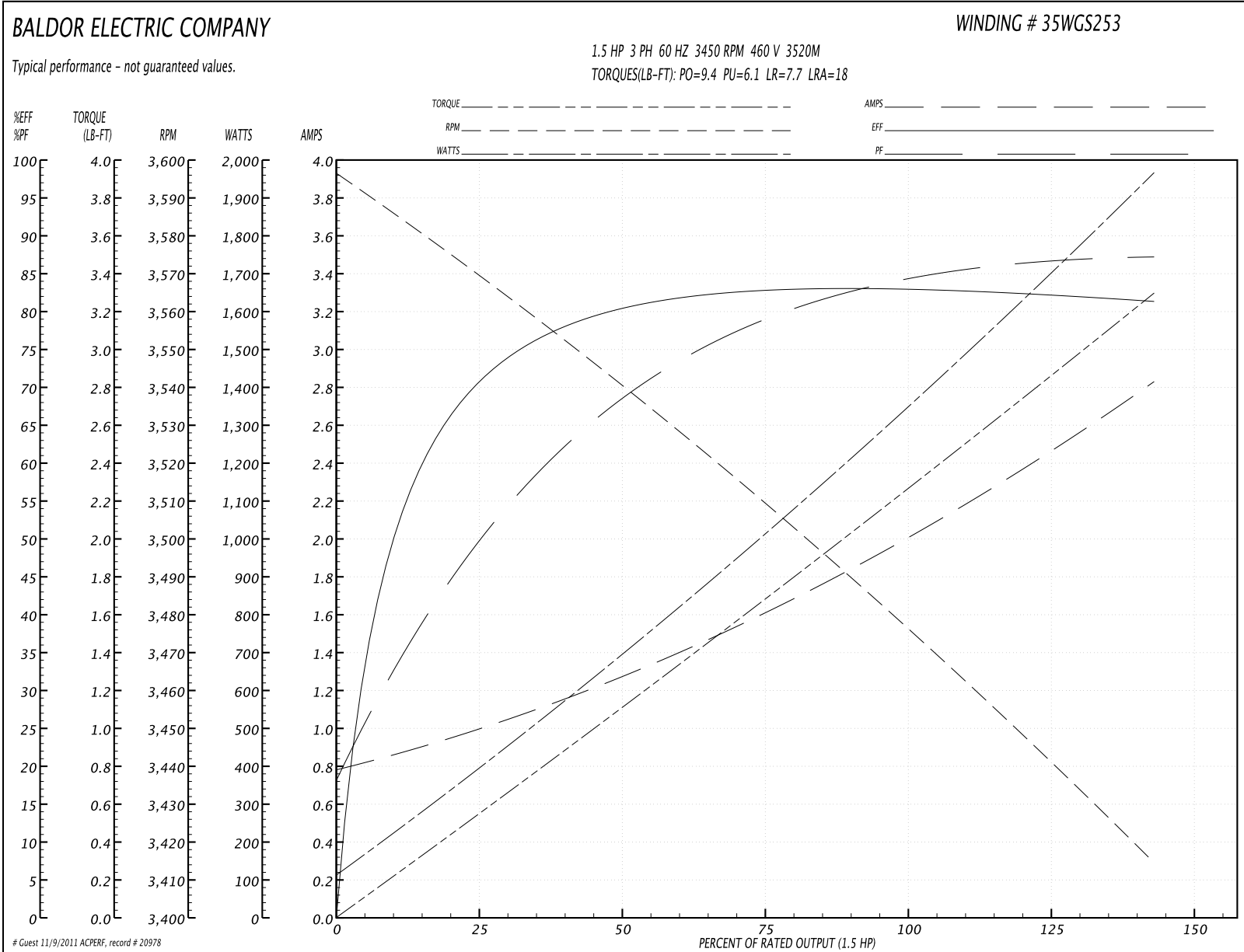

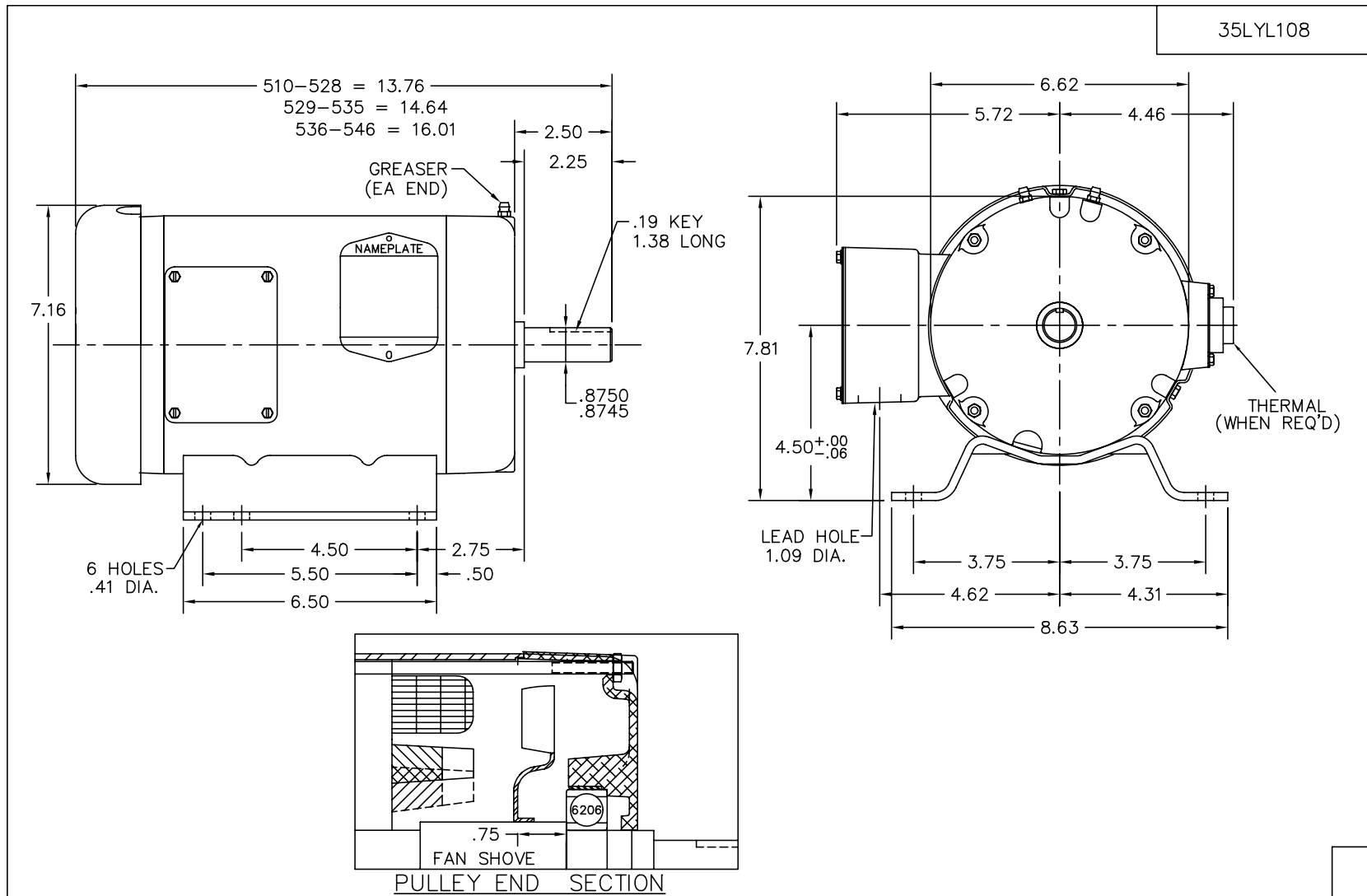

PULLEY END SECTION

CUST. NAME		CUST. P.O.		CERTIFIED BY		MODEL		INSUL		AMB	
H.P.		MTG		TYPE		R.P.M.		VOLTS		ENCL	
PHASE		FREQ		FRAME		REV. DESC: SHAFT MATERIAL CHANGE, SEE EC09 FOR MORE					
REV. LTR: F		BY: JED		REVISED: 08/17/99 7:21		TDR: 0188121		BALDOR ELECTRIC Co.			
801.71.792		FILE: AAA00013542		MDL: -							
MTL: -		STD HORZ 182-4 TEFC 35M						35LYL108			

CD0005



LOW VOLTAGE
(2Y)



LINE

HIGH VOLTAGE
(1Y)



LINE

NOTES:

1. INTERCHANGE ANY TWO LINE LEADS TO REVERSE ROTATION.
2. OPTIONAL THERMOSTATS ARE PROVIDED WHEN SPECIFIED.
3. ACTUAL NUMBER OF INTERNAL PARALLEL CIRCUITS MAY BE A MULTIPLE OF THOSE SHOWN ABOVE.
4. LEAD COLORS ARE OPTIONAL. LEADS MUST ALWAYS BE NUMBERED AS SHOWN.

REV. DESC: REVISE TO SHOW OPTIONAL COLORS

REV. LTR: E BY: JLP

REVISED: 01/19/99 10:15

TDR: 0171435

900000

FILE: AAA00005140

MDL: -

MTL: -

BALDOR ELECTRIC Co.

3PH, DV, 9 LEADS

CD0005