

BALDOR® • RELIANCE

Product Information Packet

ELECTRIC MOTOR WHOLESAL.COM

M3618T

1.5HP,850RPM,3PH,60HZ,184T,3628M,TEFC,F1

Part Detail							
Revision:	C	Status:	PRD/A	Change #:		Proprietary:	No
Type:	AC	Prod. Type:	3640M	Elec. Spec:	36WGT890	CD Diagram:	
Enclosure:	TEFC	Mfg Plant:		Mech. Spec:	36A001	Layout:	
Frame:	184T	Mounting:	F1	Poles:	08	Created Date:	05-03-2007
Base:	RG	Rotation:	R	Insulation:	F	Eff. Date:	05-06-2009
Leads:	9#16	Literature:		Elec. Diagram:		Replaced By:	

Nameplate NP1256L

CAT.NO.	M3618T						
SPEC.	36A001T890						
HP	1.5						
VOLTS	230/460						
AMP	5.6/2.8						
RPM	850						
FRAME	184T	HZ	60	PH	3		
SER.F.	1.00	CODE	H	DES	B	CLASS	F
NEMA-NOM-EFF	77	PF	65				
RATING	40C AMB-CONT						
CC	010A	USABLE AT 208V					
DE	6206	ODE	6205				
ENCL	TEFC	SN					

Parts List		
Part Number	Description	Quantity
SA157067	SA 36A001T890	1.000 EA
RA145767	RA 36A001T890	1.000 EA
36CB3004	36 CB CASTING W/1.09 DIA LEAD HOLE @ 6:0	1.000 EA
36GS1000SP	GASKET-CONDUIT BOX, .06 THICK #SV-330 LE	1.000 EA
51XB1016A08	10-16X 1/2HXWSSLD SERTYB	2.000 EA
11XW1032G06	10-32 X .38, TAPTITE II, HEX WSHR SLTD U	1.000 EA
HW3001B01	003SS CUP WASHER, FOR #8 SCREW	1.000 EA
36EP3104A01	FREP MACH W/GRSR, RAISED FH PADS	1.000 EA
HW4500A01	1641B(ALEMITE)400 UNIV, GREASE FITT	1.000 EA
HW5100A05	WVY WSHR F/205 & 304 BRGS	1.000 EA
36EP3100A01SP	PU ENDPLATE, MACH	1.000 EA
HW4500A01	1641B(ALEMITE)400 UNIV, GREASE FITT	1.000 EA
XY2520A12	1/4-20 HEX NUT, DIRECTIONAL SERRATIONS	4.000 EA
51XB1214A16	12-14X1.00 HXWSSLD SERTYB	1.000 EA
36FH4009A102SP	IEC FH GREASER W/AUTOPHERETIC PRIMER	1.000 EA
51XW1032A06	10-32 X .38, TAPTITE II, HEX WSHR SLTD S	3.000 EA
36CB4516	36 LIPPED CB LID	1.000 EA
37GS1001SP	GASKET, CONDUIT BOX LID, .06 THICK LEXID	1.000 EA
51XW0832A07	8-32 X .44, TAPTITE II, HEX WSHR SLTD SE	4.000 EA
HW2501E16	KEY, 1/4 SQ X 1.750	1.000 EA
HA7000A02	KEY RETAINER RING, 1 1/8 DIA, 1 3/8 DIA	1.000 EA
85XU0407S04	4X1/4 U DRIVE PIN STAINLESS	2.000 EA
HW3200A01	3/8-16X3/4 I-BLT WELDED F/S	1.000 EA
MJ1000A75	GREASE, POLYREX EM EXXON	0.050 LB

Parts List (continued)		
Part Number	Description	Quantity
36FN3000A01SP	EXFN, PLASTIC, 7.00 OD, .912 ID	1.000 EA
MG1000G27	PAINT- S9282E CHARCOAL GREY	0.022 GA
LB1115	LABEL,LIFTING DEVICE	1.000 EA
HA3101A28	THRUBOLT 1/4-20 X 12.500 OHIO ROD	4.000 EA
LC0005E01	CONN.DIA./WARNING LABEL (LC0005/LB1119)	1.000 EA
LB1172A01	CUSTOM MTR CARTON LABEL LASER PRINTER	1.000 EA
NP1256L	ALUM, UL CSA CC, W/O THERMAL, LASER	1.000 EA
GOPA1000	PACKAGING GROUP	1.000 EA

Accessories		
Part Number	Description	Multiplier
36-3301	C FACE KIT	A8
36EP1304A62SP	FLANGE MTD ENDPLATE 182-4TD -ENCL (LESS	A8

Performance Data at 460V, 60Hz, 1.5HP (Typical performance - Not guaranteed values)							
General Characteristics							
Full Load Torque:	9.28 LB-FT			Start Configuration:	DOL		
No-Load Current:	1.83 Amps			Break-Down Torque:	22.6 LB-FT		
Line-line Res. @ 25°C.:	10.6 Ohms A Ph / 0.0 Ohms B Ph			Pull-Up Torque:	16.4 LB-FT		
Temp. Rise @ Rated Load:	60 C			Locked-Rotor Torque:	18.6 LB-FT		
Temp. Rise @ S.F. Load:				Starting Current:	12.5 Amps		
Load Characteristics							
% of Rated Load	25	50	75	100	125	150	S.F.
Power Factor:	29.0	45.0	56.0	65.0	71.0	74.0	0.0
Efficiency:	67.7	77.1	78.8	78.1	75.9	72.2	0.0
Speed:	889.0	878.0	865.0	850.0	832.0	809.0	0.0
Line Amperes:	1.9	2.11	2.4	2.82	3.34	3.98	0.0

Performance Graph at 460V, 60Hz, 1.5HP Typical performance - Not guaranteed values

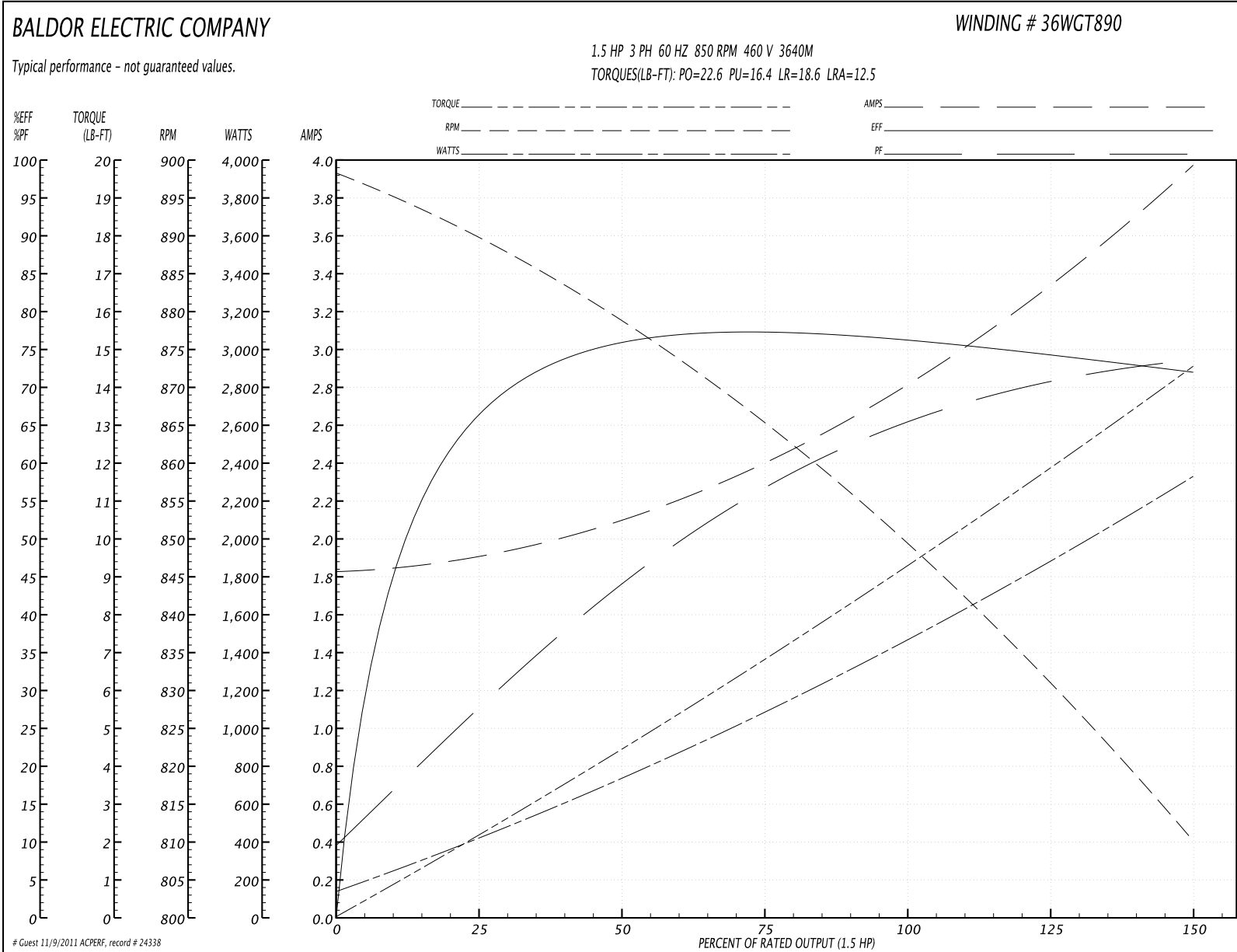

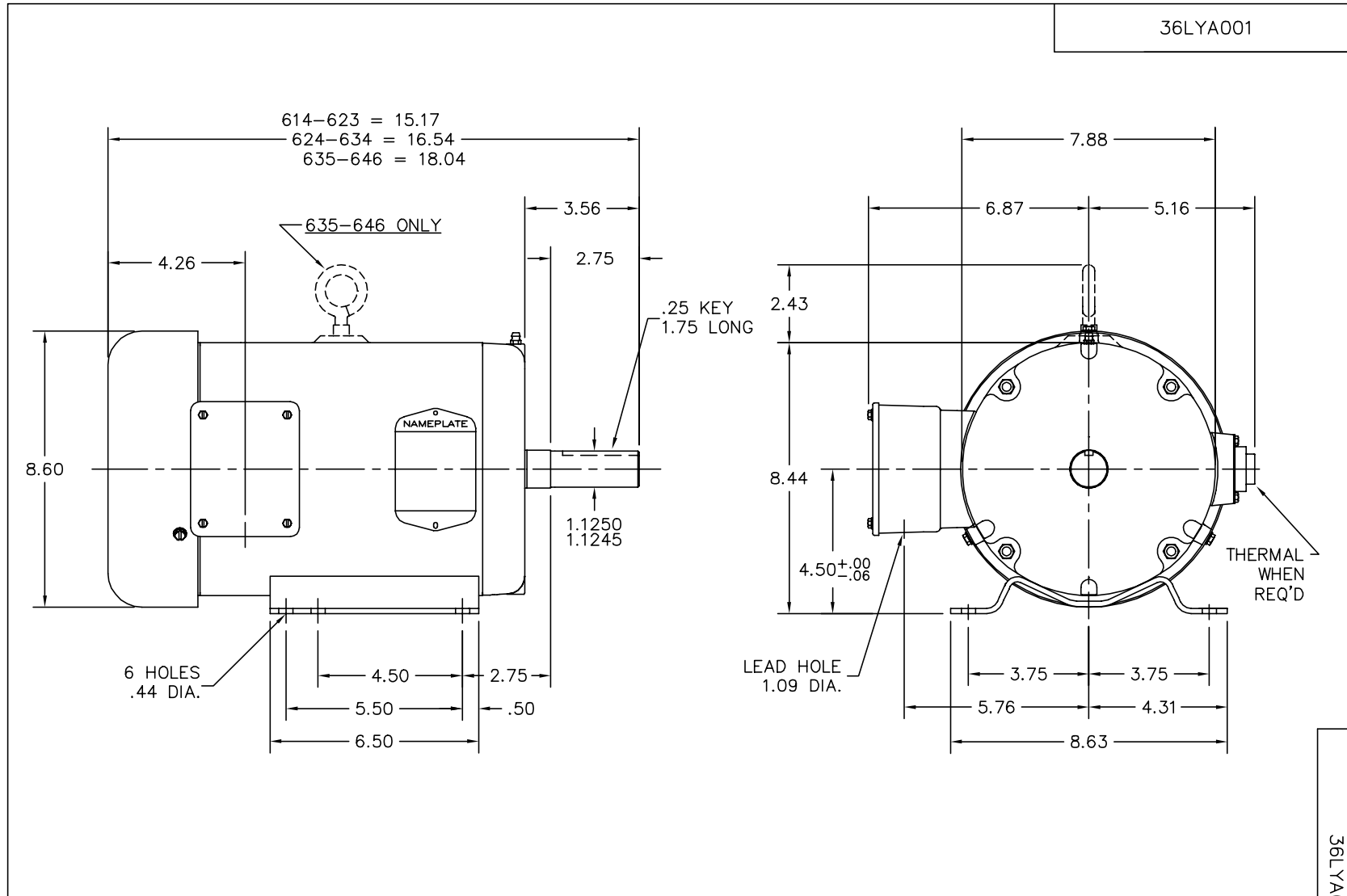

CUSTOMER IS RESPONSIBLE FOR DETERMINING THAT BALDOR'S PRODUCT WILL PERFORM SUITABLY IN THE INTENDED APPLICATION.

REV. DESC: CORRECT DESCRIPTION			
REV. LTR: U	VERSION: 04	TDR: 000000496634	
FILE: \AAA\00000\777		REVISED: 15:20:39 04/13/2009	
MTL: -		BY: ENBRAMO	

BALDOR • DODGE • RELIANCE

STD HORZ 182-4T TEFC 36M

SH 1 of 1

36LYA001

CD0005



LOW VOLTAGE
(2Y)



LINE

HIGH VOLTAGE
(1Y)

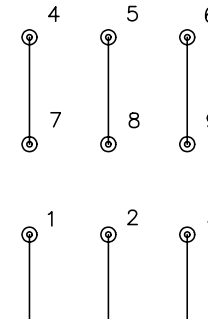

LINE

NOTES:

1. INTERCHANGE ANY TWO LINE LEADS TO REVERSE ROTATION.
2. OPTIONAL THERMOSTATS ARE PROVIDED WHEN SPECIFIED.
3. ACTUAL NUMBER OF INTERNAL PARALLEL CIRCUITS MAY BE A MULTIPLE OF THOSE SHOWN ABOVE.
4. LEAD COLORS ARE OPTIONAL. LEADS MUST ALWAYS BE NUMBERED AS SHOWN.

REV. DESC: REVISE TO SHOW OPTIONAL COLORS			
REV. LTR: E	BY: JLP	REVISED: 01/19/99 10:15	TDR: 0171435
90000		FILE: AAA00005140	MDL: -
		MTL: -	

BALDOR ELECTRIC Co.

3PH, DV, 9 LEADS

CD0005