

BALDOR® • RELIANCE

Product Information Packet

ELECTRIC MOTOR WHOLESAL.COM

M3769T

7.5HP,3500RPM,3PH,60HZ,213T,0728M,TEFC

Part Detail							
Revision:	M	Status:	INA/A	Change #:		Proprietary:	No
Type:	AC	Prod. Type:	0728M	Elec. Spec:	07WGW811	CD Diagram:	
Enclosure:	TEFC	Mfg Plant:		Mech. Spec:	07C151	Layout:	
Frame:	213T	Mounting:	F1	Poles:	02	Created Date:	
Base:	RG	Rotation:	R	Insulation:	F	Eff. Date:	11-04-2009
Leads:	9#14	Literature:		Elec. Diagram:		Replaced By:	

Nameplate NP1256L									
CAT.NO.	M3769T								
SPEC.	07C151W811H1								
HP	7.5								
VOLTS	208-230/460								
AMP	19-18/9								
RPM	3500								
FRAME	213T	HZ			60	PH	3		
SER.F.	1.15	CODE			J	DES	A	CLASS	F
NEMA-NOM-EFF	88.5	PF			88				
RATING	40C AMB-CONT								
CC	010A	USABLE AT 208V			19				
DE	6307	ODE			6206				
ENCL	TEFC	SN							

Parts List		
Part Number	Description	Quantity
SA041092	SA 07C151W811H1	1.000 EA
RA036959	RA 07C151W811H1	1.000 EA
S/P101-000-000	EPACT PROCEDURES-FS PLANT-POLYREX EM, NO	1.000 EA
HW3201A05	3/8-16 EYEBOLT	1.000 EA
09CB3002SP	CB W/1.38 LEAD HOLE FOR 37, 39, 307 & 30	1.000 EA
09GS1000SP	GASKET-CONDUIT BOX, 1/16 THICK LEXIDE	1.000 EA
51XW2520A12	.25-20 X .75, TAPTITE II, HEX WSHR SLTD	2.000 EA
11XW1032G06	10-32 X .38, TAPTITE II, HEX WSHR SLTD U	1.000 EA
HW3001B01	003SS CUP WASHER, FOR #8 SCREW	1.000 EA
37EP1100A01	FR ENDPLATE MACH	1.000 EA
HW4500A01	1641B(ALEMITE)400 UNIV, GREASE FITT	1.000 EA
HW5100A06	W2420-025 WVY WSHR (WB)	1.000 EA
37EP1101A01	PU ENDPLATE MACH	1.000 EA
HW4500A01	1641B(ALEMITE)400 UNIV, GREASE FITT	1.000 EA
XY3118A12	5/16-18 HEX NUT DIRECTIONAL SERRATION	4.000 EA
51XB1214A20	12-14X1.25 HXWSSLD SERTYB	1.000 EA
07FH4007SP	IEC FH W/GRSR, NOTCH @ 6:00 & 3 FAN CVR	1.000 EA
51XW1032A06	10-32 X .38, TAPTITE II, HEX WSHR SLTD S	3.000 EA
09CB3501SP	CONDUIT BOX LID FOR 09CB3001 & 09CB3002	1.000 EA
09GS1013SP	09 GS FOR 09CB3501 LID - LEXIDE	1.000 EA
51XW2520A12	.25-20 X .75, TAPTITE II, HEX WSHR SLTD	2.000 EA
HW2501F21	KEY, 5/16 SQ X 2.375	1.000 EA
HA7000A02	KEY RETAINER RING, 1 1/8 DIA, 1 3/8 DIA	1.000 EA
85XU0407S04	4X1/4 U DRIVE PIN STAINLESS	2.000 EA

Parts List (continued)		
Part Number	Description	Quantity
LB1115	LABEL,LIFTING DEVICE	1.000 EA
MJ1000A75	GREASE, POLYREX EM EXXON	0.050 LB
HA3104A32	THRUBOLT- 5/16-18 X12.750	4.000 EA
MG1000G27	PAINT- S9282E CHARCOAL GREY	0.036 GA
36FN3000C02	EXFN, PLASTIC, 5.25 OD, 1.175 ID	1.000 EA
LB1125C04	STD-E (STOCK CTN LABEL STD-E WITH FLAG)	1.000 EA
NP1256L	ALUM, UL CSA CC, W/O THERMAL, LASER	1.000 EA
LC0005E01	CONN.DIA./WARNING LABEL (LC0005/LB1119)	1.000 EA
07PA1011	PKG GRP, 07 CAST IRON PK1181	1.000 EA
10XL3808A28	3/8 X 1 3/4" LAG SCREW	2.000 EA

Accessories		
Part Number	Description	Multiplier
37-1304	C FACE KIT	A8

Performance Data at 460V, 60Hz, 7.5HP (Typical performance - Not guaranteed values)
General Characteristics

Full Load Torque:	11.3 LB-FT	Start Configuration:	DOL
No-Load Current:	2.82 Amps	Break-Down Torque:	43.7 LB-FT
Line-line Res. @ 25°C.:	1.18 Ohms A Ph / 0.0 Ohms B Ph	Pull-Up Torque:	24.5 LB-FT
Temp. Rise @ Rated Load:	45 C	Locked-Rotor Torque:	26.2 LB-FT
Temp. Rise @ S.F. Load:	53 C	Starting Current:	74.5 Amps

Load Characteristics

% of Rated Load	25	50	75	100	125	150	S.F.
Power Factor:	62.0	79.0	85.0	88.0	90.0	90.0	89.0
Efficiency:	82.2	88.2	89.6	89.7	89.2	88.1	89.4
Speed:	3572.0	3547.0	3520.0	3492.0	3461.0	3426.0	3473.0
Line Amperes:	3.69	5.21	7.06	9.02	11.1	13.43	10.27

Performance Graph at 460V, 60Hz, 7.5HP Typical performance - Not guaranteed values

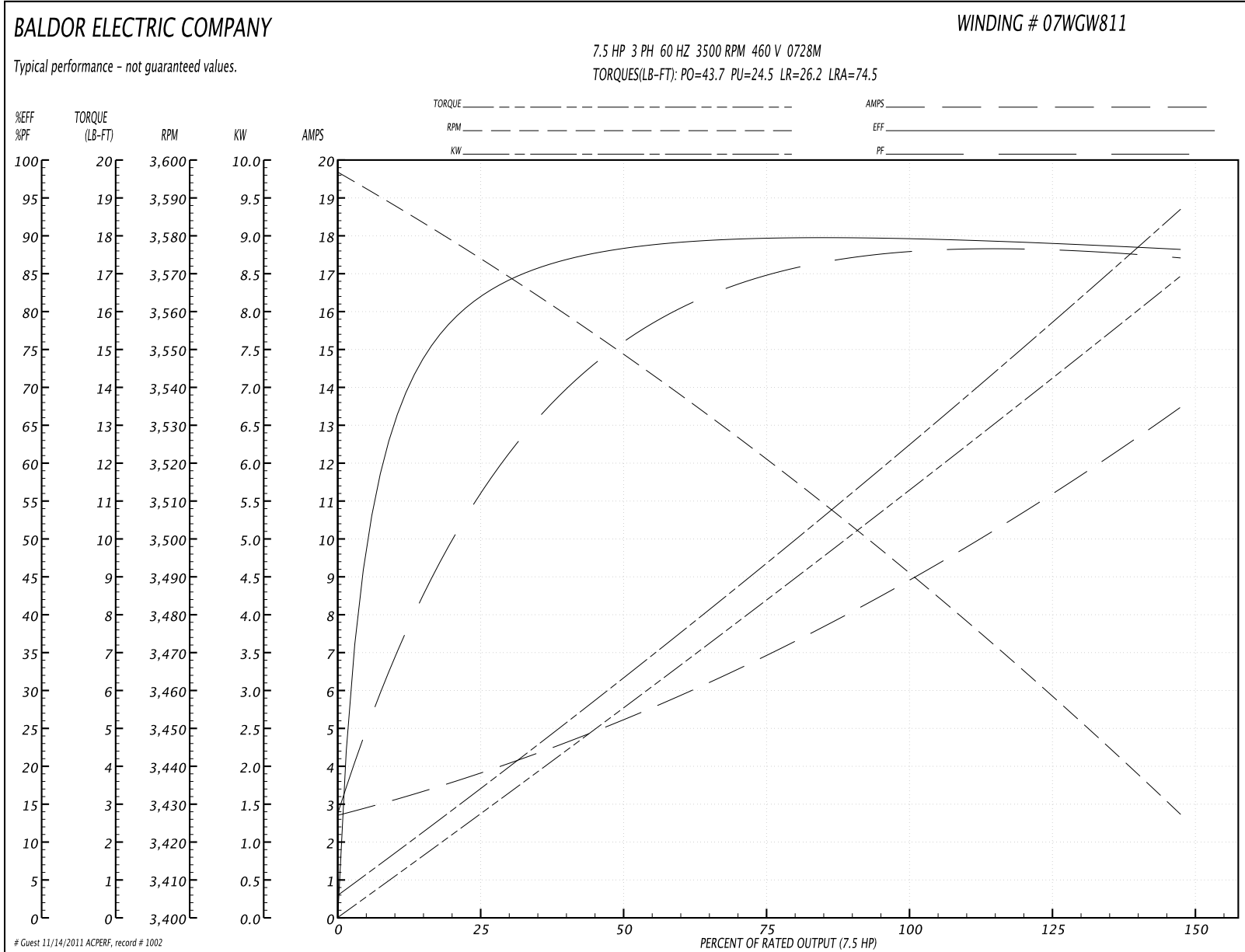

07LYC151

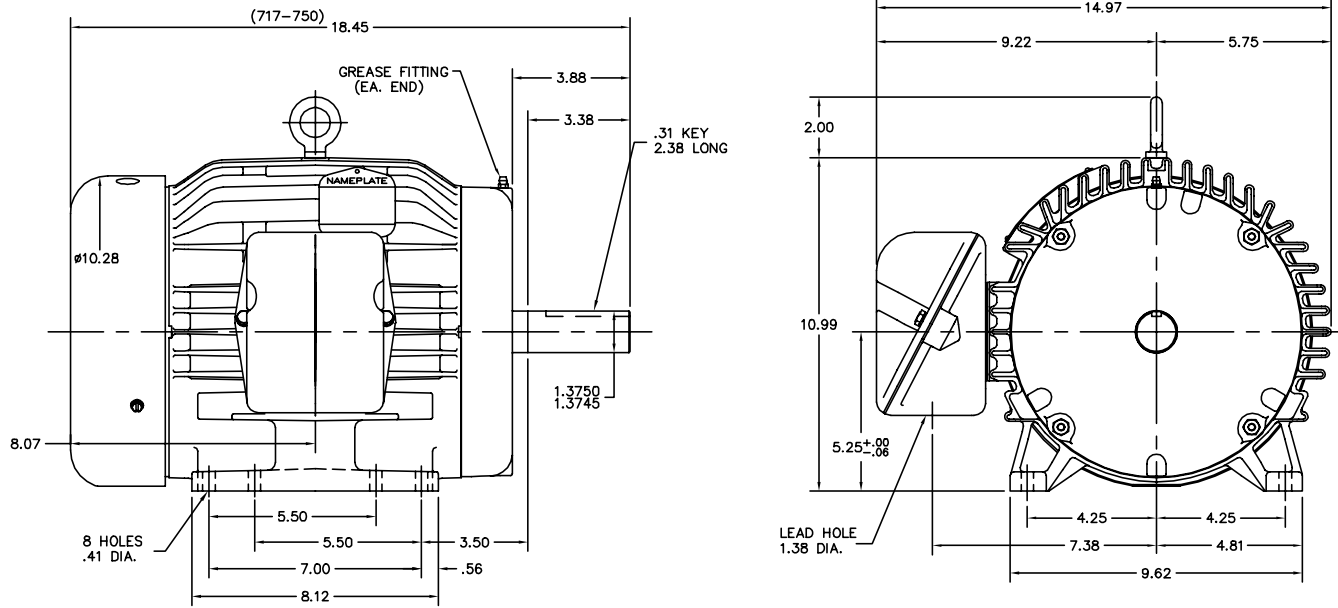

CUSTOMER IS RESPONSIBLE FOR DETERMINING THAT MOTOR PERFORMANCE IS SUITABLE IN THE APPLICATION.

REV. DESC: ADDED KOBX LEAD HOLE DIM.			
REV. LTR: H	BY: RMP	REVISED: 08:10:41 08/26/2003	TDR: 311090
FILE: AAA00002648		REF: 07LYC151	
MTL: -			

BALDOR ELECTRIC Co.

HORZ 213-5T TEFC 307M

07LYC151

CD0005



LOW VOLTAGE
(2Y)



LINE

HIGH VOLTAGE
(1Y)



LINE

NOTES:

1. INTERCHANGE ANY TWO LINE LEADS TO REVERSE ROTATION.
2. OPTIONAL THERMOSTATS ARE PROVIDED WHEN SPECIFIED.
3. ACTUAL NUMBER OF INTERNAL PARALLEL CIRCUITS MAY BE A MULTIPLE OF THOSE SHOWN ABOVE.
4. LEAD COLORS ARE OPTIONAL. LEADS MUST ALWAYS BE NUMBERED AS SHOWN.

REV. DESC: REVISE TO SHOW OPTIONAL COLORS			
REV. LTR: E	BY: JLP	REVISED: 01/19/99 10:15	TDR: 0171435
900000		FILE: AAA00005140	MDL: -
		MTL: -	

BALDOR ELECTRIC Co.

3PH, DV, 9 LEADS

CD0005