

# **BALDOR® • RELIANCE**

**Product Information Packet**

**ELECTRIC MOTOR WHOLESALE.COM**

**M3771T**

**10HP,3500RPM,3PH,60HZ,215T,0732M,TEFC,F1**

Part Detail							
Revision:	H	Status:	INA/A	Change #:		Proprietary:	No
Type:	AC	Prod. Type:	0732M	Elec. Spec:	07WGX136	CD Diagram:	
Enclosure:	TEFC	Mfg Plant:		Mech. Spec:	07C151	Layout:	
Frame:	215T	Mounting:	F1	Poles:	02	Created Date:	
Base:	RG	Rotation:	R	Insulation:	F	Eff. Date:	04-12-2010
Leads:	9#14	Literature:		Elec. Diagram:		Replaced By:	

**Nameplate NP1256L**

CAT.NO.	M3771T						
SPEC.	07C151X136H1						
HP	10						
VOLTS	230/460						
AMP	23/11.5						
RPM	3500						
FRAME	215T	HZ	60	PH	3		
SER.F.	1.15	CODE	H	DES	B	CLASS	F
NEMA-NOM-EFF	89.5	PF	91				
RATING	40C AMB-CONT						
CC	010A	USABLE AT 208V	25				
DE	6307	ODE	6206				
ENCL	TEFC	SN					

Parts List		
Part Number	Description	Quantity
SA067953	SA 07C151X136H1	1.000 EA
RA061965	RA 07C151X136H1	1.000 EA
36FN3000C02	EXFN, PLASTIC, 5.25 OD, 1.175 ID	1.000 EA
S/P101-000-000	EPACT PROCEDURES-FS PLANT-POLYREX EM, NO	1.000 EA
HW3201A05	3/8-16 EYEBOLT	1.000 EA
09CB3002SP	CB W/1.38 LEAD HOLE FOR 37, 39, 307 & 30	1.000 EA
09GS1000SP	GASKET-CONDUIT BOX, 1/16 THICK LEXIDE	1.000 EA
51XW2520A12	.25-20 X .75, TAPTITE II, HEX WSHR SLTD	2.000 EA
11XW1032G06	10-32 X .38, TAPTITE II, HEX WSHR SLTD U	1.000 EA
HW3001B01	003SS CUP WASHER, FOR #8 SCREW	1.000 EA
37EP1100A01	FR ENDPLATE MACH	1.000 EA
HW4500A01	1641B(ALEMITE)400 UNIV, GREASE FITT	1.000 EA
HW5100A06	W2420-025 WVY WSHR (WB)	1.000 EA
37EP1101A01	PU ENDPLATE MACH	1.000 EA
HW4500A01	1641B(ALEMITE)400 UNIV, GREASE FITT	1.000 EA
XY3118A12	5/16-18 HEX NUT DIRECTIONAL SERRATION	4.000 EA
51XB1214A20	12-14X1.25 HXWSSLD SERTYB	1.000 EA
07FH4007SP	IEC FH W/GRSR, NOTCH @ 6:00 & 3 FAN CVR	1.000 EA
51XW1032A06	10-32 X .38, TAPTITE II, HEX WSHR SLTD S	3.000 EA
09CB3501SP	CONDUIT BOX LID FOR 09CB3001 & 09CB3002	1.000 EA
09GS1013SP	09 GS FOR 09CB3501 LID - LEXIDE	1.000 EA
51XW2520A12	.25-20 X .75, TAPTITE II, HEX WSHR SLTD	2.000 EA
HW2501F21	KEY, 5/16 SQ X 2.375	1.000 EA
HA7000A02	KEY RETAINER RING, 1 1/8 DIA, 1 3/8 DIA	1.000 EA

Parts List (continued)		
Part Number	Description	Quantity
85XU0407S04	4X1/4 U DRIVE PIN STAINLESS	2.000 EA
LB1115	LABEL,LIFTING DEVICE	1.000 EA
MJ1000A75	GREASE, POLYREX EM EXXON	0.050 LB
HA3104A32	THRUBOLT- 5/16-18 X12.750	4.000 EA
MG1000G27	PAINT- S9282E CHARCOAL GREY	0.036 GA
LB1125C04	STD-E (STOCK CTN LABEL STD-E WITH FLAG)	1.000 EA
LC0005E01	CONN.DIA./WARNING LABEL (LC0005/LB1119)	1.000 EA
NP1256L	ALUM, UL CSA CC, W/O THERMAL, LASER	1.000 EA
07PA1011	PKG GRP, 07 CAST IRON PK1181	1.000 EA
10XL3808A28	3/8 X 1 3/4" LAG SCREW	2.000 EA

Accessories		
Part Number	Description	Multiplier
37-1304	C FACE KIT	A8

07LYC151

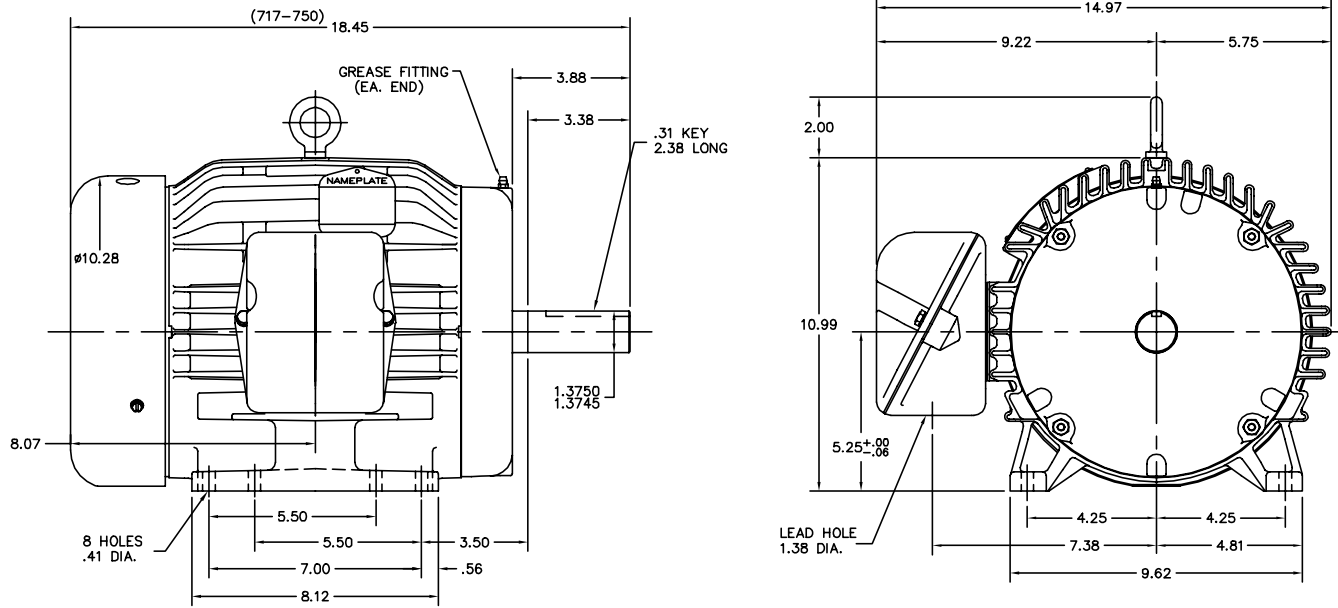

CUSTOMER IS RESPONSIBLE FOR DETERMINING THAT MOTOR PERFORMANCE IS SUITABLE IN THE APPLICATION.

REV. DESC: ADDED KOBX LEAD HOLE DIM.			
REV. LTR: H	BY: RMP	REVISED: 08:10:41 08/26/2003	TDR: 311090
FILE: AAA00002648		REF: 07LYC151	
MTL: -			

**BALDOR ELECTRIC Co.**

HORZ 213-5T TEFC 307M

07LYC151

CD0005

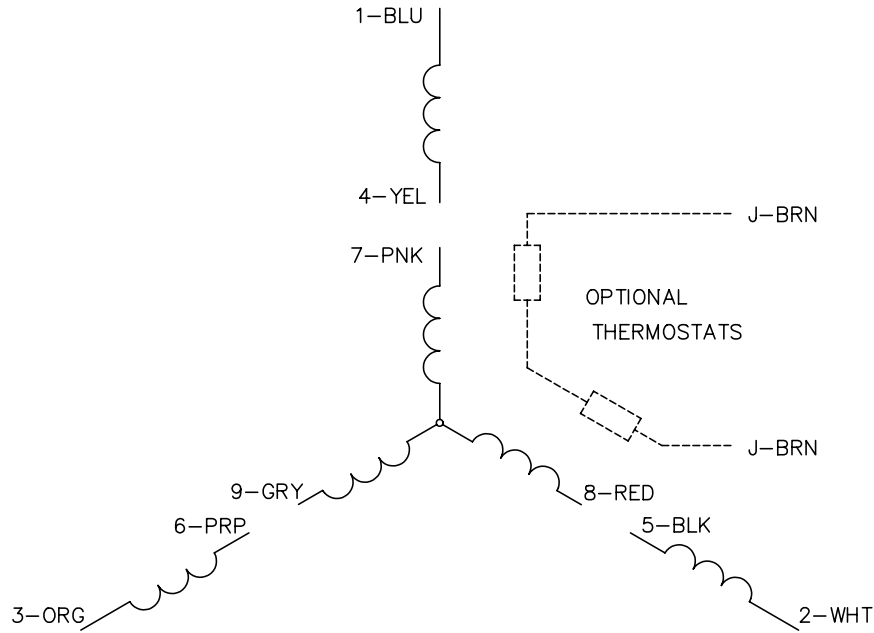

LOW VOLTAGE  
(2Y)

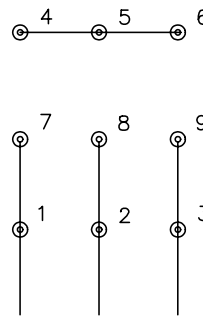

LINE

HIGH VOLTAGE  
(1Y)

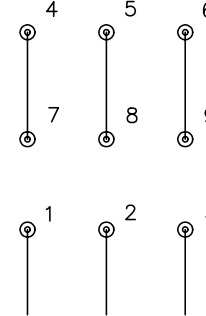

LINE

NOTES:

1. INTERCHANGE ANY TWO LINE LEADS TO REVERSE ROTATION.
2. OPTIONAL THERMOSTATS ARE PROVIDED WHEN SPECIFIED.
3. ACTUAL NUMBER OF INTERNAL PARALLEL CIRCUITS MAY BE A MULTIPLE OF THOSE SHOWN ABOVE.
4. LEAD COLORS ARE OPTIONAL. LEADS MUST ALWAYS BE NUMBERED AS SHOWN.

REV. DESC: REVISE TO SHOW OPTIONAL COLORS

REV. LTR: E BY: JLP

REVISED: 01/19/99 10:15

TDR: 0171435

900000

FILE: AAA00005140

MDL: -

MTL: -

**BALDOR ELECTRIC Co.**

3PH, DV, 9 LEADS

CD0005