

# **BALDOR® • RELIANCE**

**Product Information Packet**

**ELECTRIC MOTOR WHOLESAL.COM**

**M4106**

**20HP,3525RPM,3PH,60HZ,286U,0940M,TEFC,F1**

Part Detail							
Revision:	-	Status:	PRD/A	Change #:		Proprietary:	No
Type:	AC	Prod. Type:	0940M	Elec. Spec:	09WGY152	CD Diagram:	
Enclosure:	TEFC	Mfg Plant:		Mech. Spec:	09F608	Layout:	
Frame:	286U	Mounting:	F1	Poles:	02	Created Date:	04-28-2010
Base:	RG	Rotation:	R	Insulation:	F	Eff. Date:	05-03-2010
Leads:	9#12	Literature:		Elec. Diagram:		Replaced By:	

**Nameplate NP1256L**

CAT.NO.	M4106						
SPEC.	09F608Y152H2						
HP	20						
VOLTS	230/460						
AMP	46/23						
RPM	3525						
FRAME	286U	HZ	60	PH	3		
SER.F.	1.15	CODE	J	DES	B	CLASS	F
NEMA-NOM-EFF	90.2	PF	90				
RATING	40C AMB-CONT						
CC	010A	USABLE AT 208V					
DE	6311	ODE	6208				
ENCL	TEFC	SN					

Parts List		
Part Number	Description	Quantity
SA194154	SA 09F608Y152H2	1.000 EA
RA181744	RA 09F608Y152H2	1.000 EA
S/P101-000-003	EPACT PROC-ZK 280FR & UP,LARGE KOBX,POLY	1.000 EA
10CB3000SP	STD KO BOX MODEL 310,312,314 MTRS W/2.00	1.000 EA
12GS1000SP	GASKET	1.000 EA
10XN3118K12	5/16-18 X .75 GRADE 5, ZINC PLATED	4.000 EA
HW1001A31	LOCKWASHER 5/16, ZINC PLT.591 OD, .319 I	4.000 EA
WD1000B16	KPA-4C BURNDY TERMINAL	1.000 EA
11XW1032G06	10-32 X .38, TAPTITE II, HEX WSHR SLTD U	1.000 EA
09EP1100A14SP	ENDPLATE, MACH	1.000 EA
HA4051A00	PLASTIC CAP FOR GREASE FITTING	1.000 EA
XY3816A12	3/8-16 FINISHED NUT	4.000 EA
HW1001A38	LOCKWASHER 3/8, ZINC PLT .688 OD, .382 I	4.000 EA
HW5100A08	W3118-035 WVY WSHR (WB)	1.000 EA
10XN2520K28	1/4-20 X 1.75" HX HD SCRWGRADE 5, ZINC P	2.000 EA
HW1001A25	LOCKWASHER 1/4, ZINC PLT .493 OD, .255 I	2.000 EA
10XN3118K40	5/16-18 X 2.50" HEX HD, GRADE 5	4.000 EA
HW1001A31	LOCKWASHER 5/16, ZINC PLT.591 OD, .319 I	4.000 EA
09EP1116A01	PU ENDPLATE, MACH	1.000 EA
HA4051A00	PLASTIC CAP FOR GREASE FITTING	1.000 EA
HA3113A15	THRUBOLT 3/8-16 X 18.875 W/3.50 THD LENG	4.000 EA
09FH4000SP	FAN COVER, STAMPED	1.000 EA
HA2081A05	SPACER TUBE, 309 FAN HSG, 2.00 LONG	4.000 EA
XY3816A12	3/8-16 FINISHED NUT	4.000 EA

Parts List (continued)		
Part Number	Description	Quantity
HW1001A38	LOCKWASHER 3/8, ZINC PLT .688 OD, .382 I	4.000 EA
10CB3500SP	CONDUIT BOX LID, CAST	1.000 EA
10GS1000SP	GASKET, CONDUIT BOX LID	1.000 EA
51XW2520A12	.25-20 X .75, TAPTITE II, HEX WSHR SLTD	4.000 EA
HW4600B40	V-RING SLINGER 2.000 X 2.680 X 0.280	1.000 EA
HW2501G32	KEY, 3/8 SQ X 3.750	1.000 EA
LB1115	LABEL,LIFTING DEVICE	1.000 EA
HW4500A05	1669B ALEM/UNIV860 GR FTG X	1.000 EA
HW4500A17	317400 ALEMITE GREASE RELIEF	1.000 EA
HA4001A01SP	DRAIN PLUG, PLASTIC (MICRO PLAS)	1.000 EA
MJ1000A75	GREASE, POLYREX EM EXXON	0.080 LB
HW4500A03	GREASE FITTING, .125 NPT 1610(ALEMITE) 8	1.000 EA
HW4500A17	317400 ALEMITE GREASE RELIEF	1.000 EA
HA4001A01SP	DRAIN PLUG, PLASTIC (MICRO PLAS)	1.000 EA
09FN3001C01	EXTERNAL FAN, PLASTIC	1.000 EA
HW2500A25	WOODRUFF KEY USA #1008 #BLOW CARBON STEE	1.000 EA
51XB1214A20	12-14X1.25 HXWSSLD SERTYB	1.000 EA
MG1000G27	PAINT- S9282E CHARCOAL GREY	0.050 GA
85XU0407A04	#4-7 X 1/4 DRIVE PIN	2.000 EA
LB5040	INSTRUCTION TAG, AC & DC	1.000 EA
LB1125C04	STD-E (STOCK CTN LABEL STD-E WITH FLAG)	4.000 EA
LC0005E02	SPL CONN.DIA./WARN.LABEL(LC0005/LB1119)	1.000 EA
NP1256L	ALUM, UL CSA CC, W/O THERMAL, LASER	1.000 EA
40PA1005	PACKAGING GROUP, 09 STD	1.000 EA

Accessories		
Part Number	Description	Multiplier
09-1310	C FACE KIT	A8

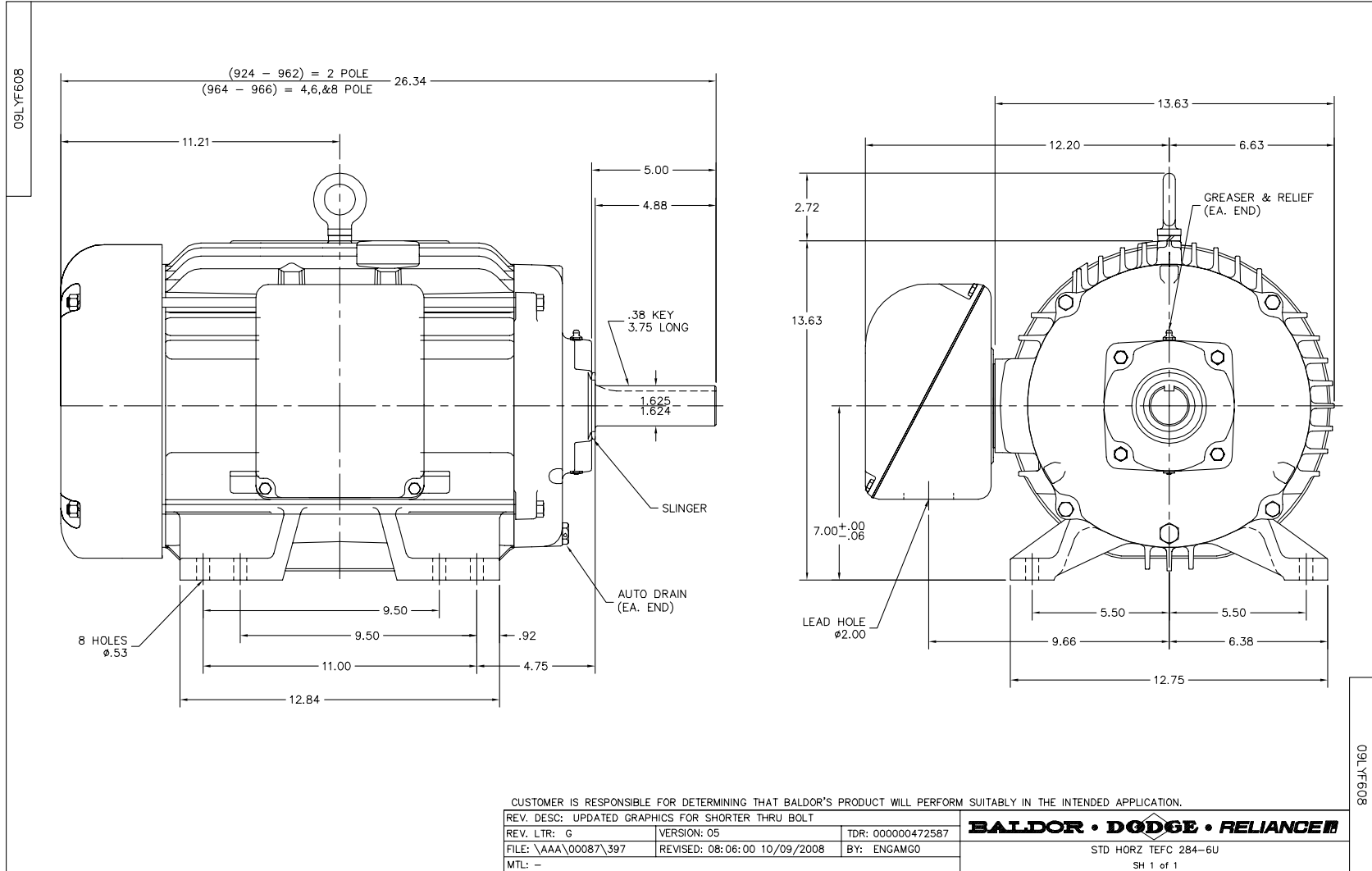

CD0005

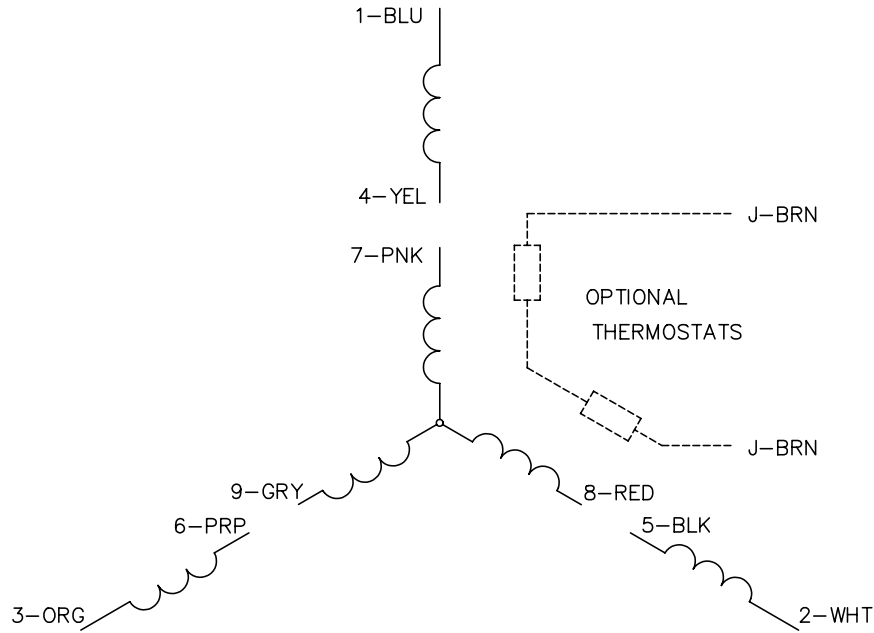

LOW VOLTAGE  
(2Y)

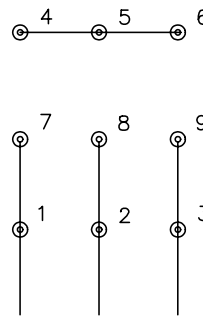

LINE

HIGH VOLTAGE  
(1Y)

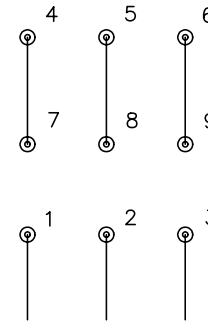

LINE

NOTES:

1. INTERCHANGE ANY TWO LINE LEADS TO REVERSE ROTATION.
2. OPTIONAL THERMOSTATS ARE PROVIDED WHEN SPECIFIED.
3. ACTUAL NUMBER OF INTERNAL PARALLEL CIRCUITS MAY BE A MULTIPLE OF THOSE SHOWN ABOVE.
4. LEAD COLORS ARE OPTIONAL. LEADS MUST ALWAYS BE NUMBERED AS SHOWN.

REV. DESC: REVISE TO SHOW OPTIONAL COLORS			
REV. LTR: E	BY: JLP	REVISED: 01/19/99 10:15	TDR: 0171435
900000		FILE: AAA00005140	MDL: -
		MTL: -	

**BALDOR ELECTRIC Co.**

3PH, DV, 9 LEADS

CD0005