

# **BALDOR® • RELIANCE**

**Product Information Packet**

**ELECTRIC MOTOR WHOLESALE.COM**

**VM2514T**

**20HP,3470RPM,3PH,60HZ,254TC,3739M,ODTF,F**

Part Detail							
Revision:	-	Status:	PRD/A	Change #:		Proprietary:	No
Type:	AC	Prod. Type:	3739M	Elec. Spec:	37WGS635	CD Diagram:	
Enclosure:	ODTF	Mfg Plant:		Mech. Spec:	37F336	Layout:	
Frame:	254TC	Mounting:	F1	Poles:	02	Created Date:	09-07-2010
Base:	N	Rotation:	R	Insulation:	F	Eff. Date:	09-11-2010
Leads:	9#12	Literature:		Elec. Diagram:		Replaced By:	

Nameplate NP1256L									
CAT.NO.	VM2514T								
SPEC.	37F336S635H1								
HP	20								
VOLTS	208-230/460								
AMP	52-48/24								
RPM	3470								
FRAME	254TC	HZ	60	PH	3				
SER.F.	1.15	CODE	G	DES	A	CLASS	F		
NEMA-NOM-EFF	90.2	PF	86						
RATING	40C AMB-CONT								
CC	010A	USABLE AT 208V							
DE	6309	ODE	6206						
ENCL	ODTF	SN							

Parts List		
Part Number	Description	Quantity
SA202710	SA 37F336S635H1	1.000 EA
RA189986	RA 37F336S635H1	1.000 EA
S/P101-000-000	EPACT PROCEDURES-FS PLANT-POLYREX EM, NO	1.000 EA
HW3200A01	3/8-16X3/4 I-BLT WELDED F/S	1.000 EA
09CB3000SP	CONDUIT BOX CAST	1.000 EA
19XW2520A16	SCREW,1/4-20X1 TAPTITE-II OR ROLOC 91	2.000 EA
HA6429	KO BOX ADAPTER REXITE	2.000 EA
11XW1032G06	10-32 X .38, TAPTITE II, HEX WSHR SLTD U	1.000 EA
HW3001B01	003SS CUP WASHER, FOR #8 SCREW	1.000 EA
37EP3200A03	FR ENDPLATE MACH	1.000 EA
HW4500A01	1641B(ALEMITE)400 UNIV, GREASE FITT	1.000 EA
HW5100A06	W2420-025 WVY WSHR (WB)	1.000 EA
37EP3401A03	PUEP OPEN 309 BRG W/BAFFLE, GRS	1.000 EA
37AD2000A02	BAFFLE PLATE, STAMPED PLATED	1.000 EA
60XW0632A06	6-32 X 3/8 TORX HEAD SCREW TAPTITE II	4.000 EA
HW4500A01	1641B(ALEMITE)400 UNIV, GREASE FITT	1.000 EA
10XN2520A36	1/4-20X 2 1/4 HEX HD X	4.000 EA
HW1001A25	LOCKWASHER 1/4, ZINC PLT .493 OD, .255 I	4.000 EA
XY3118A12	5/16-18 HEX NUT DIRECTIONAL SERRATION	4.000 EA
37FN3002A01SP	EXFN, PLASTIC, 9.00 OD, 1.155 ID	1.000 EA
51XB1214A20	12-14X1.25 HXWSSLD SERTYB	1.000 EA
37FH4000A05SP	DRIP COVER, W/ AUTOPHERETIC PRIMER	1.000 EA
51XW1032A06	10-32 X .38, TAPTITE II, HEX WSHR SLTD S	3.000 EA
09CB3500SP	CONDUIT BOX LID, CAST	1.000 EA

Parts List (continued)		
Part Number	Description	Quantity
51XW2520A12	.25-20 X .75, TAPTITE II, HEX WSHR SLTD	2.000 EA
HW2501G25	KEY, 3/8 SQ X 2.875	1.000 EA
85XU0407S04	4X1/4 U DRIVE PIN STAINLESS	2.000 EA
LB1115	LABEL,LIFTING DEVICE	1.000 EA
MJ1000A75	GREASE, POLYREX EM EXXON	0.050 LB
MG1000G27	PAINT- S9282E CHARCOAL GREY	0.028 GA
HA3104A35	THRUBOLT .31-18 X 13.687	4.000 EA
LB1125C04	STD-E (STOCK CTN LABEL STD-E WITH FLAG)	1.000 EA
LC0005E01	CONN.DIA./WARNING LABEL (LC0005/LB1119)	1.000 EA
NP1256L	ALUM, UL CSA CC, W/O THERMAL, LASER	1.000 EA
GOPA1000	PACKAGING GROUP	1.000 EA
PK3082	STYROFOAM CRADLE	1.000 EA

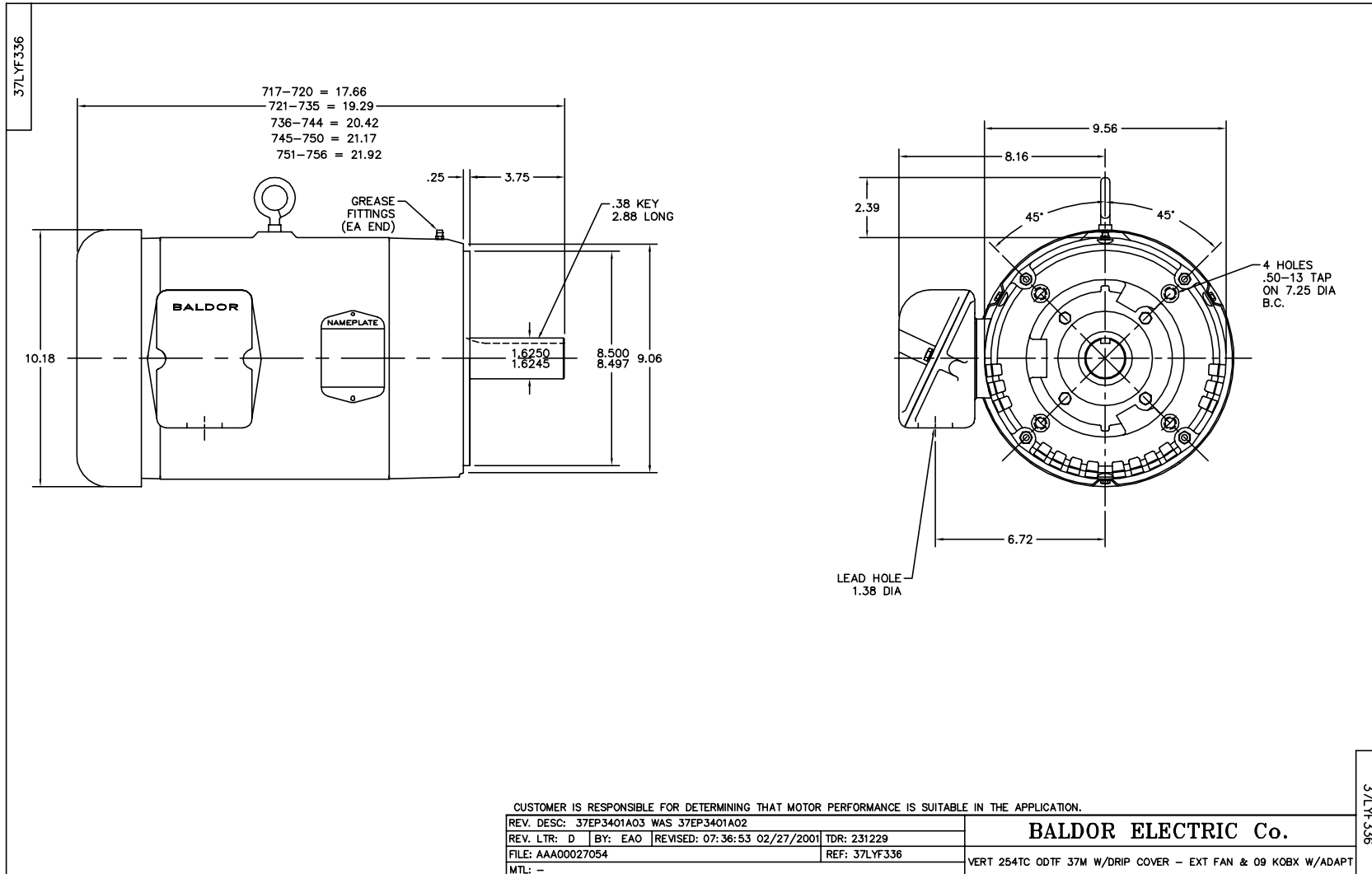

CD0005



LOW VOLTAGE  
(2Y)

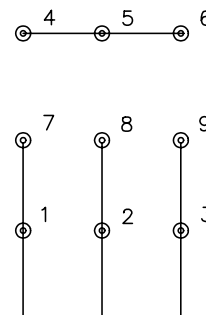

LINE

HIGH VOLTAGE  
(1Y)

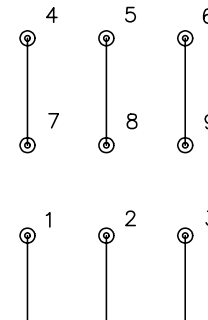

LINE

NOTES:

1. INTERCHANGE ANY TWO LINE LEADS TO REVERSE ROTATION.
2. OPTIONAL THERMOSTATS ARE PROVIDED WHEN SPECIFIED.
3. ACTUAL NUMBER OF INTERNAL PARALLEL CIRCUITS MAY BE A MULTIPLE OF THOSE SHOWN ABOVE.
4. LEAD COLORS ARE OPTIONAL. LEADS MUST ALWAYS BE NUMBERED AS SHOWN.

REV. DESC: REVISE TO SHOW OPTIONAL COLORS			
REV. LTR: E	BY: JLP	REVISED: 01/19/99 10:15	TDR: 0171435
900000		FILE: AAA00005140	MDL: -
		MTL: -	

**BALDOR ELECTRIC Co.**

3PH, DV, 9 LEADS

CD0005