

BALDOR® • RELIANCE

Product Information Packet

ELECTRIC MOTOR WHOLESAL.COM

VM3158T

3HP,3450RPM,3PH,60HZ,145TC,3528M,OPEN,F1

Part Detail							
Revision:	B	Status:	PRD/A	Change #:		Proprietary:	No
Type:	AC	Prod. Type:	3528M	Elec. Spec:	35WGR986	CD Diagram:	
Enclosure:	OPEN	Mfg Plant:		Mech. Spec:	35BB005	Layout:	
Frame:	145TC	Mounting:	F1	Poles:	02	Created Date:	06-07-2010
Base:	N	Rotation:	R	Insulation:	F	Eff. Date:	04-11-2011
Leads:	9#18	Literature:		Elec. Diagram:		Replaced By:	

Nameplate NP1256L									
CAT.NO.	VM3158T								
SPEC.	35BB005R986H1								
HP	3								
VOLTS	208-230/460								
AMP	8.2-7.4/3.7								
RPM	3450								
FRAME	145TC	HZ			60	PH	3		
SER.F.	1.15	CODE			K	DES	B	CLASS	F
NEMA-NOM-EFF	84	PF			89				
RATING	40C AMB-CONT								
CC	010A	USABLE AT 208V			8.2				
DE	6205	ODE			6203				
ENCL	OPEN	SN							

Parts List		
Part Number	Description	Quantity
SA198117	SA 35BB005R986H1	1.000 EA
RA185484	RA 35BB005R986H1	1.000 EA
S/P101-000-000	EPACT PROCEDURES-FS PLANT-POLYREX EM, NO	1.000 EA
NS2512A01	INSULATOR, CONDUIT BOX X	1.000 EA
35CB3009	35 CB CASTING W/1.09 DIA. LEAD HOLE @ 6:	1.000 EA
51XB1016A07	10-16 X 7/16 HXWSSLD SERTYB	2.000 EA
11XW1032G06	10-32 X .38, TAPTITE II, HEX WSHR SLTD U	1.000 EA
35EP3201A02	FR ENDPLATE, MACH	1.000 EA
HW4500A01	1641B(ALEMITE)400 UNIV, GREASE FITT	1.000 EA
HW5100A03SP	WAVY WASHER (W1543-017)	1.000 EA
35EP3400A14	SPL FACE MTD END PLATE - OPEN-143-5TC-05	1.000 EA
35AD2000	AIR BAFFLE	1.000 EA
60XW0632A06	6-32 X 3/8 TORX HEAD SCREW TAPTITE II	4.000 EA
HW4500A01	1641B(ALEMITE)400 UNIV, GREASE FITT	1.000 EA
51XN1032A20	10-32 X 1 1/4 HX WS SL SR	2.000 EA
51XB1214A16	12-14X1.00 HXWSSLD SERTYB	1.000 EA
35FH4006A04	DRIP COVER SPECIAL, W/ AUTOPHERETIC PRIM	1.000 EA
51XW1032A06	10-32 X .38, TAPTITE II, HEX WSHR SLTD S	3.000 EA
35CB4521	35 LIPPED CB LID (GALV & PHOSPH)	1.000 EA
51XW0832A07	8-32 X .44, TAPTITE II, HEX WSHR SLTD SE	4.000 EA
HW2501D13SP	KEY, 3/16 SQ X 1.375	1.000 EA
HA7000A01	KEY RETAINER 7/8" DIA SHAFT	1.000 EA
85XU0407S04	4X1/4 U DRIVE PIN STAINLESS	2.000 EA
MJ1000A75	GREASE, POLYREX EM EXXON	0.050 LB

Parts List (continued)		
Part Number	Description	Quantity
35FN3002A05SP	EXFN, PLASTIC, 6.376 OD, .638 ID	1.000 EA
MG1000G27	PAINT- S9282E CHARCOAL GREY	0.017 GA
HA3100A15	THRUBOLT 10-32 X 8.375	4.000 EA
LB1125C04	STD-E (STOCK CTN LABEL STD-E WITH FLAG)	1.000 EA
LC0005E01	CONN.DIA./WARNING LABEL (LC0005/LB1119)	1.000 EA
LB5040	INSTRUCTION TAG, AC & DC	1.000 EA
NP1256L	ALUM, UL CSA CC, W/O THERMAL, LASER	1.000 EA
34PA1005	PACKING GROUP, BALDOR	1.000 EA
PK3082	STYROFOAM CRADLE	1.000 EA

35LYBB005

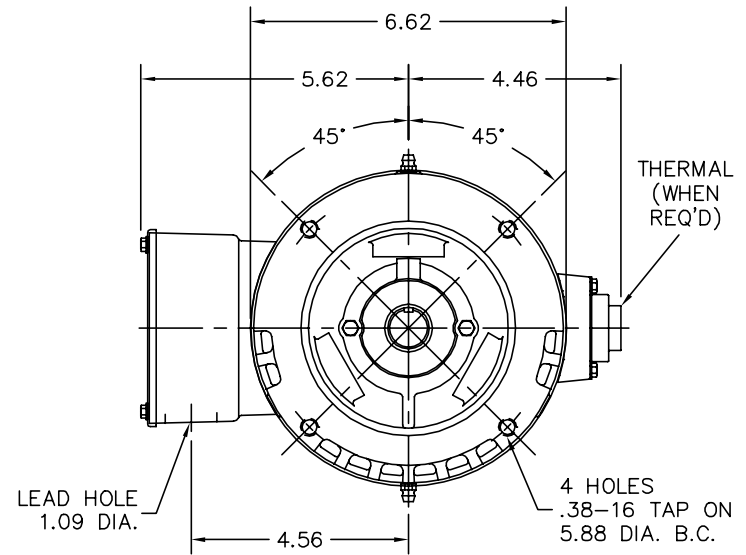
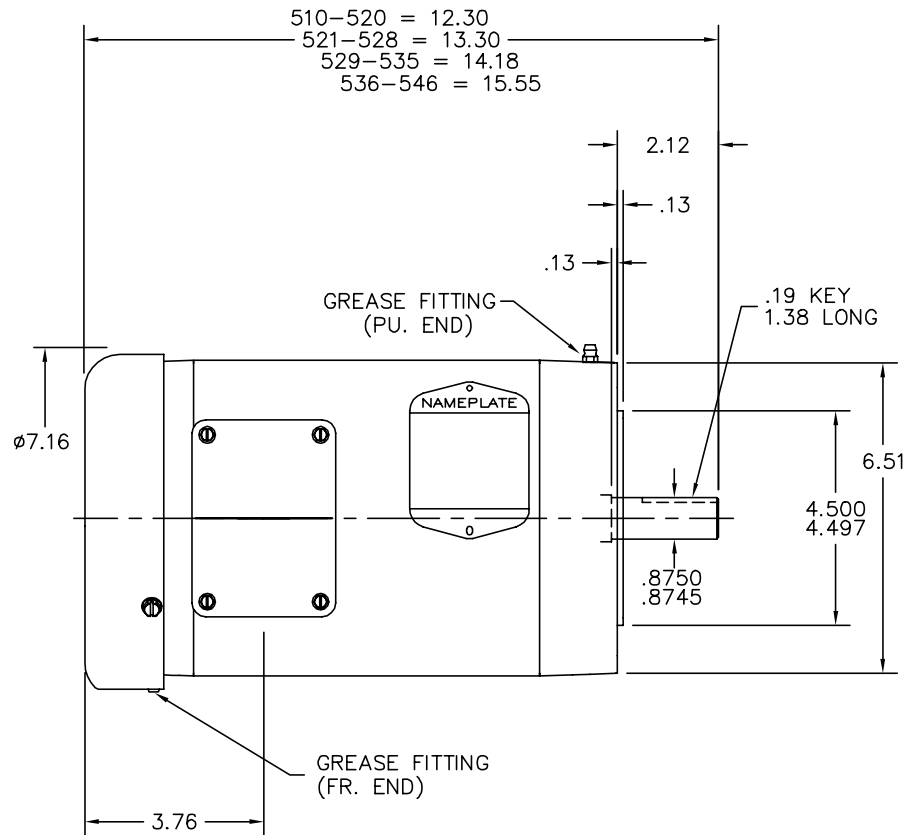

CUSTOMER IS RESPONSIBLE FOR DETERMINING THAT BALDOR'S PRODUCT WILL PERFORM SUITABLY IN THE INTENDED APPLICATION.

REV. DESC: NEW		
REV. LTR: -	VERSION: 00	TDR: 000000542534
FILE: \AAA\00172\253	REVISED: 09:14:48 06/01/2010	
MTL: -	BY: ENJERWO	

BALDOR • DODGE • RELIANCE

STD VER 143-5TC ODTF 35M W/DRIP CVR, EXT FAN, 1.09 LEAD HOLE

SH 1 of 1

35LYBB005

CD0005



LOW VOLTAGE
(2Y)

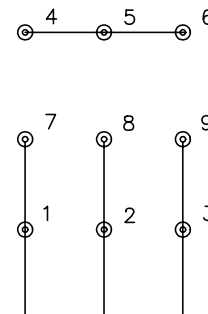

LINE

HIGH VOLTAGE
(1Y)

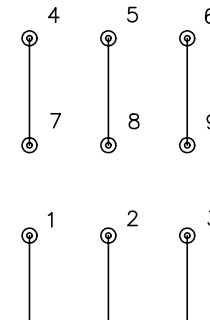

LINE

NOTES:

1. INTERCHANGE ANY TWO LINE LEADS TO REVERSE ROTATION.
2. OPTIONAL THERMOSTATS ARE PROVIDED WHEN SPECIFIED.
3. ACTUAL NUMBER OF INTERNAL PARALLEL CIRCUITS MAY BE A MULTIPLE OF THOSE SHOWN ABOVE.
4. LEAD COLORS ARE OPTIONAL. LEADS MUST ALWAYS BE NUMBERED AS SHOWN.

REV. DESC: REVISE TO SHOW OPTIONAL COLORS			
REV. LTR: E	BY: JLP	REVISED: 01/19/99 10:15	TDR: 0171435
900000		FILE: AAA00005140	MDL: -
		MTL: -	

BALDOR ELECTRIC Co.

3PH, DV, 9 LEADS

CD0005