

# **BALDOR® • RELIANCE**

**Product Information Packet**

**ELECTRIC MOTOR WHOLESAL.COM**

**VM3664T**

**2HP,1165RPM,3PH,60HZ,184TC,0633M,TEFC,F1**

Part Detail							
Revision:	-	Status:	PRD/A	Change #:		Proprietary:	No
Type:	AC	Prod. Type:	0633M	Elec. Spec:	06WGX133	CD Diagram:	
Enclosure:	TEFC	Mfg Plant:		Mech. Spec:	06C103	Layout:	
Frame:	184TC	Mounting:	F1	Poles:	06	Created Date:	11-29-2010
Base:	N	Rotation:	R	Insulation:	F	Eff. Date:	12-08-2010
Leads:	9#16	Literature:		Elec. Diagram:		Replaced By:	

**Nameplate NP1256L**

CAT.NO.	VM3664T						
SPEC.	06C103X133H1						
HP	2						
VOLTS	208-230/460						
AMP	7.2-6.6/3.3						
RPM	1165						
FRAME	184TC	HZ	60	PH	3		
SER.F.	1.15	CODE	K	DES	B	CLASS	F
NEMA-NOM-EFF	86.5	PF	66				
RATING	40C AMB-CONT						
CC	010A	USABLE AT 208V					
DE	6206	ODE	6205				
ENCL	TEFC	SN					

Parts List		
Part Number	Description	Quantity
SA212575	SA 06C103X133H1	1.000 EA
RA199804	RA 06C103X133H1	1.000 EA
36FN3000B01	EXFN, PLASTIC, 6.00 OD, .912 ID	1.000 EA
S/P101-000-000	EPACT PROCEDURES-FS PLANT-POLYREX EM, NO	1.000 EA
HW3201A05	3/8-16 EYEBOLT	1.000 EA
06CB3000	CONDUIT BOX CAST	1.000 EA
06GS1000	GASKET, CONDUIT BOX	1.000 EA
51XW2520A12	.25-20 X .75, TAPTITE II, HEX WSHR SLTD	2.000 EA
11XW1032G06	10-32 X .38, TAPTITE II, HEX WSHR SLTD U	1.000 EA
HW3001B01	003SS CUP WASHER, FOR #8 SCREW	1.000 EA
36EP1101A01	FR ENDPLATE, MACH	1.000 EA
HW4500A01	1641B(ALEMITE)400 UNIV, GREASE FITT	1.000 EA
HW5100A05	WVY WSHR F/205 & 304 BRGS	1.000 EA
36EP1300A01SP	PU ENDPLATE, MACH	1.000 EA
HW4500A01	1641B(ALEMITE)400 UNIV, GREASE FITT	1.000 EA
10XN2520A26	1/4-20X 1 5/8 HEX HD	4.000 EA
HA3101A34	THRUBOLT- 1/4-20 X 10.375	4.000 EA
36FH4009A03SP	IEC FH , W/ AUTOPHERETIC PRIMER	1.000 EA
51XW1032A06	10-32 X .38, TAPTITE II, HEX WSHR SLTD S	3.000 EA
06CB3500	CONDUIT BOX LID - ALUMINUM DIE CAST	1.000 EA
06GS1001	GASKET, CONDUIT BOX LID	1.000 EA
51XW2520A12	.25-20 X .75, TAPTITE II, HEX WSHR SLTD	2.000 EA
HW2501E16	KEY, 1/4 SQ X 1.750	1.000 EA
HA7000A02	KEY RETAINER RING, 1 1/8 DIA, 1 3/8 DIA	1.000 EA

Parts List (continued)		
Part Number	Description	Quantity
LB1115	LABEL,LIFTING DEVICE	1.000 EA
85XU0407S04	4X1/4 U DRIVE PIN STAINLESS	2.000 EA
MJ1000A75	GREASE, POLYREX EM EXXON	0.050 LB
51XB1214A16	12-14X1.00 HXWSSLD SERTYB	1.000 EA
MG1000G27	PAINT- S9282E CHARCOAL GREY	0.028 GA
LB1125C04	STD-E (STOCK CTN LABEL STD-E WITH FLAG)	1.000 EA
LC0005E01	CONN.DIA./WARNING LABEL (LC0005/LB1119)	1.000 EA
NP1256L	ALUM, UL CSA CC, W/O THERMAL, LASER	1.000 EA
36PA1001	PACKAGING GROUP	1.000 EA
PK3082	STYROFOAM CRADLE	1.000 EA

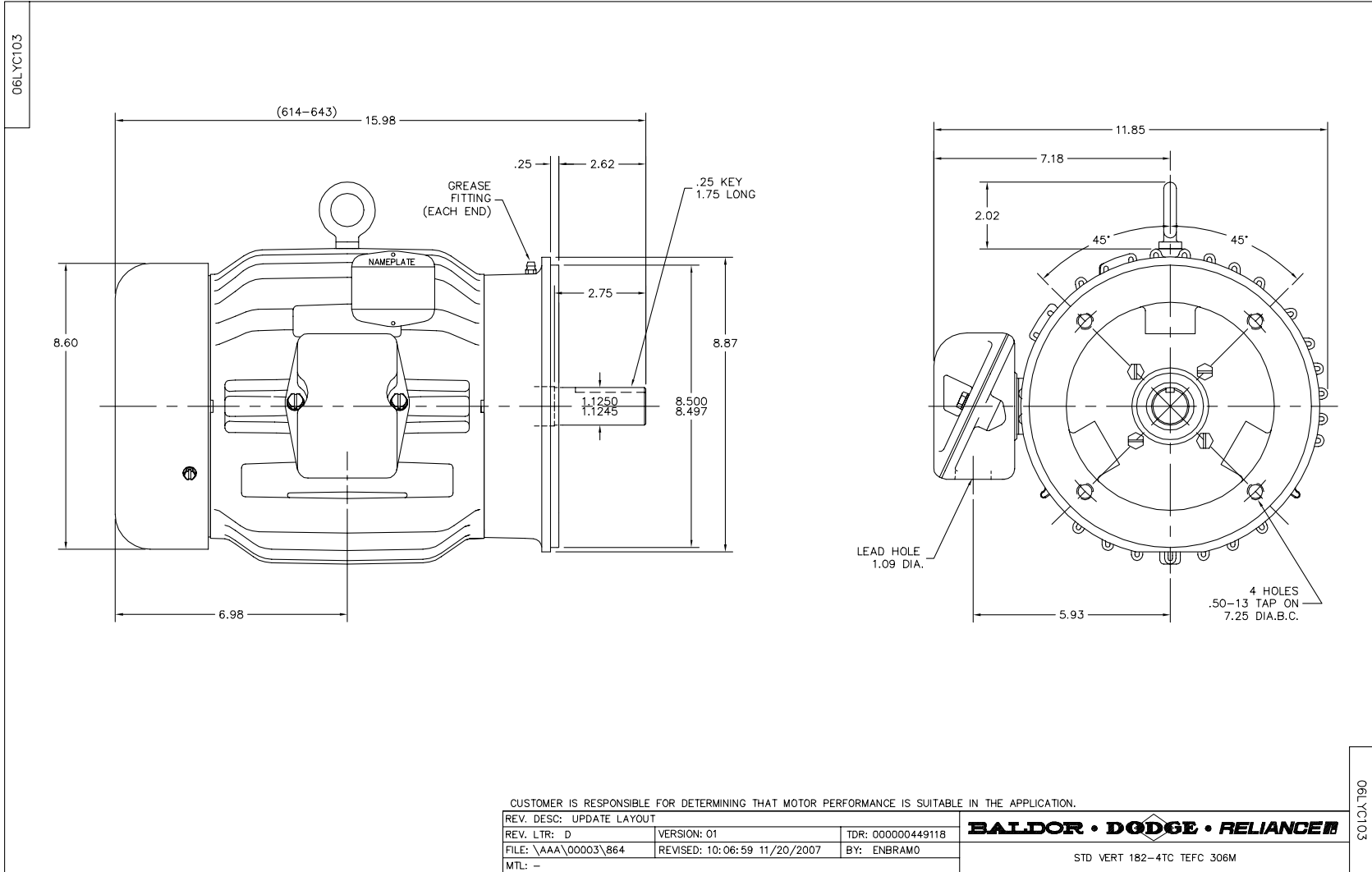

CD0005

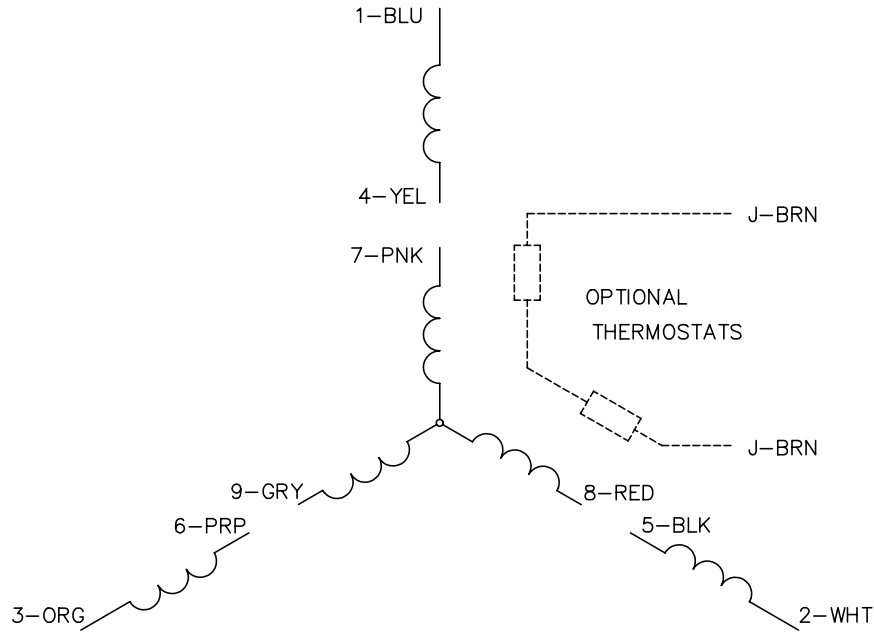

LOW VOLTAGE  
(2Y)

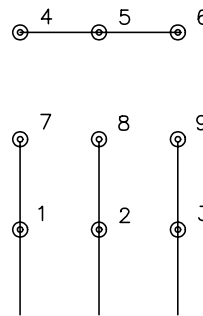

LINE

HIGH VOLTAGE  
(1Y)

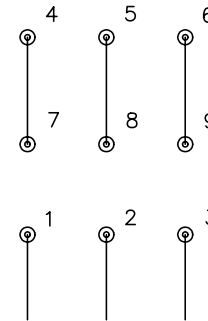

LINE

NOTES:

1. INTERCHANGE ANY TWO LINE LEADS TO REVERSE ROTATION.
2. OPTIONAL THERMOSTATS ARE PROVIDED WHEN SPECIFIED.
3. ACTUAL NUMBER OF INTERNAL PARALLEL CIRCUITS MAY BE A MULTIPLE OF THOSE SHOWN ABOVE.
4. LEAD COLORS ARE OPTIONAL. LEADS MUST ALWAYS BE NUMBERED AS SHOWN.

REV. DESC: REVISE TO SHOW OPTIONAL COLORS			
REV. LTR: E	BY: JLP	REVISED: 01/19/99 10:15	TDR: 0171435
900000		FILE: AAA00005140	MDL: -
		MTL: -	

**BALDOR ELECTRIC Co.**

3PH, DV, 9 LEADS

CD0005