

BALDOR®

A MEMBER OF THE ABB GROUP



AC Drives Solutions



Baldor Drives Industrial AC Drives

Baldor is leading the field in industrial motor and drive technologies, as well as designing and manufacturing some of the most exciting motion control products available on the market today. Our V*S range defines quality, reliability and performance, utilizing easy-to-use interfaces, intuitive programming and the capability to meet any application need.

Strength and Depth

Baldor V*S Drives are grouped into 3 categories to provide functionality and performance across the widest range of applications:

- High Performance Drives
- Pump and Fan Drives
- Microdrives

High Performance

No other drives on the market can offer you the consistent performance and user-friendly approach of the Baldor V*S High Performance AC Drives – no matter what voltage, power rating, or performance level your application demands. With their powerful processor and advanced design features, these drives assure you the highest level of control.

Pump and Fan

The VS1PF Pump and Fan Drive is a feature rich AC drive targeted at the pump and fan market but with functionality that rivals more sophisticated products. The VS1PF achieves traditional energy savings by controlling centrifugal loads with a variable torque speed curve, and unique algorithms that can further reduce energy consumed by your application.

Microdrives

Competitive in price, and compact, the Baldor V*S Microdrives feature user-friendly interfaces and design elements that assure consistent motor control throughout a wide range of voltages, horsepowers, and enclosure types. Ranging from 1/2 to 30 Hp (0.37 to 22 kW) stock ratings, these performance-proven microdrives are well suited for a wide range of applications.

Industrial Drives Features

- High Performance, Pump and Fan, Washdown and Microdrives to match your application
- Closed Loop Vector, Sensorless or Volts per Hertz control
- Standard and Washdown enclosures NEMA 1 or NEMA 4X (IP66)
- Mint® WorkBench Software, DriveView PC Programming or CopyCat Loader setup options
- Models offer optional add on cards for flexible application control
- Power ratings from 1/2 to 700 Hp (0.37 to 520 kW)



Table of Contents

Baldor VS1SM & Series 5	8
OEM Single Phase Analog Microdrives	
Baldor VS1ST Drive	10
Micro-drive, Starter – Style IP20 Mount	
Baldor VS1MX Drive.	12
Microdrive; NEMA 4X (IP66)and NEMA 12 (IP55)	
Baldor VS1MD Drive.	16
Microdrive; Sensorless Vector, NEMA 1 Kit	
Baldor VS1PF Drive	20
Pump and Fan Drive; PID Loop, Bypass Option	
Baldor VS1SP & VS1GV Drives.	24
High Performance Sensorless or Vector Control	
Baldor VS1SD & VS1PM Drives.	30
Servo Drive Control Permanent Magnet Control	
Baldor Flexible Solutions	31
Packaged Drive Controls	

Total Automation Solutions



Drives

- Inverter
- Pump and Fan
- Washdown
- Vector
- Servo



Motors

- Induction
- Variable Speed
- Rotary / Linear
- Servo
- Stepper

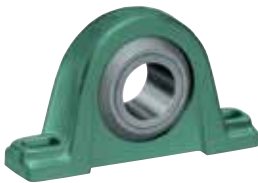

Mechanical

- Gearing
- Pulleys
- Bearings
- Sheaves
- Couplings



Accessories

- Software
- Keypads
- Communications
- Cables
- I/O Cards

More than just Drives

Baldor Electric can provide your complete automation solutions as the industry leading manufacturing of not only AC Drives but Motors, Mechanical Gearing, Operator Interface and Servo Drives. This provides you with one point of contact for your automation needs and you can get back to the important task of bringing your machine to market that much faster.

Complete Solutions

Baldor has 80 years of experience providing leading industrial drive solutions. This experience is applied to every drive product to ensure cost effective, easy to use and operate products that are flexible enough to meet any application requirement.

Flexibility and Versatility

Baldor VS1 Drives offer the best in flexibility and versatility. If your needs call for a basic micro drive then the VS1ST or VS1MD is the drive for you. The VS1MX follows this standard of a basic easy to use drive in an enclosed NEMA 12 (IP55) or NEMA 4X (IP66) package.

Pump and Fan Applications are ideal for the VS1PF with its built in Energy Savings features, and the optional Bypass cabinet is available for typical HVAC installations.

If High Performance is your requirement, this can be tackled using the award winning VS1SP, VS1GV, VS1SD or VS1PM products. Each is based on the same hardware and software platform with the ability to provide varying levels of control. From Sensorless, Closed Loop Vector all the way up to Servo Control, these drives can handle even the most demanding performance requirements. Standard built in PLC logic and the programming capability of Mint® software increases the flexibility and versatility of the VS1 product line.

Energy Savings / Life of the Machine

Energy costs are rising and machine efficiency is now a key challenge for modern machine design. When applied in any of a wide variety of applications, A-C variable speed drives provide valuable benefits. These devices save energy when used in variable volume pump/fan applications. Significant energy savings can result when variable speed drives are used to control the industrial process. Another advantage is the inherent soft-starting nature (due to ramping up of voltage to speed) which eliminates inrush current associated with starting across the line. This reduces mechanical wear and tear on equipment.

Getting Started Quickly

Our drives are designed for ease of use the moment you take them out of the box. Start the accompanying Windows based programming software (Mint® WorkBench – High Performance or DriveView – Micro & Pump/Fan) front end and commission the drive with confidence.

Ease of Programming

Operator Interface layout makes running, programming and monitor of the drives a snap. The keys on the keypad depress so you “feel” the key has been pushed. Pump/Fan and Performance products utilize a graphical display so that parameters and monitor can be read on a standard text display. Programming parameters are arranged in logic groups with the most common startup parameters first.

New Generation of VS1 Drives from Baldor Electric

With the increasing emphasis on cost reducing the manufacturing process, many companies are looking to ac drives and replacing fixed speed applications with variable speed or upgrading their systems. Flexibility, quality, durability and reliability – all have become the keys to application solutions in today's industrial world. Our products operate around the globe in thousands of applications, making sure consumers and businesses alike receive the products they demand in this ever changing dynamic economy.

Baldor Electric is recognized around the world as the standard for quality, reliability and performance. The same level of commitment is the benchmark for our VS1 AC Drives available in a Micro, Pump/Fan and High Performance family of products. These products have been designed as the simplest drives to program, startup and operate. The user-friendly approach was a key design requirement for all VS1 AC Drives.

Selection Guide

The Baldor Drive Solution Guide will provide you with details on each drive in the VS1 family, assisting in the selection of the appropriate ac drive for your application.

Enclosure Options

Drives can be supplied as an IP20 drive to be mounted in an enclosure or as completely enclosed packages. The drive controller can be supplied in a NEMA 1, ventilated enclosure, which is meant for clean environments. NEMA 12 (IP55) is totally enclosed and suitable for dusty or oily environments; or NEMA 4X (IP66) for dust proof water tight applications.

Application Features

Selecting the best ac drive involves establishing several factors: load characteristics, environment, control method, communication requirements, space availability and available input power. Some common points to consider when selecting a drive are:

- | | |
|-------------------------|---|
| • Load Characteristics | Constant torque or a variable torque |
| • Speed Range | Minimum and maximum operating speeds |
| • Power Rating | Horsepower or amp rating of the motor |
| • Speed Regulation | Accuracy of speed as load changes |
| • Stopping & Duty Cycle | Coast or ramp to a stop, braking requirements |
| • Control Method | Keypad, analog, or digital input |
| • Communications | Network interface |
| • Space Restrictions | Mounting location and physical size of drive |
| • Environment | Ambient temperature and atmosphere |

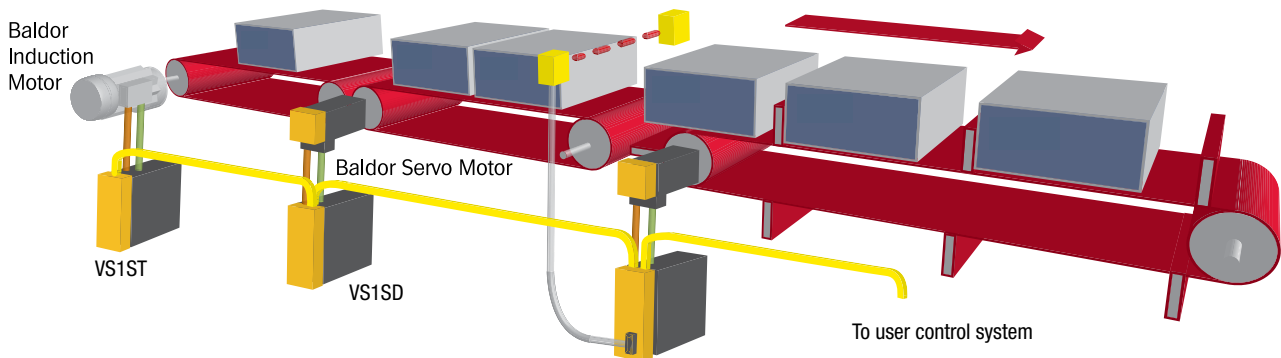

Unique Capabilities



VS1ST
IP20 Starter Replacement
DIN Rail Mount
Low Cost
Easy to Wire and Install
Basic Parameter Set



VS1SP
General Purpose Drive
Sensorless Vector Control
Advanced LCD Display
NEMA 4X (IP66) Ratings
Wide Range of Options



VS1MX
NEMA 12 (IP55) or
NEMA 4X (IP66) Enclosure
Local Disconnect
Potentiometer/Switch Control
Basic Parameter Set



VS1GV
High Performance Drive
Closed Loop Vector Control
LCD Display with Help Text
Encoder Feedback Standard
PLC Functionality



VS1MD
High Performance Micro
Easy to Program
Built In LED Display
Advanced Capability
Communication Options



VS1SD
Servo Positioning Control
Resolver Input Standard
PLC Functionality
Application Macros
Mint® Workbench Program



VS1PM
Permanent Magnet Control
Resolver Input Standard
Matched Motor Design
Ultra High Energy Efficient
Power Dense Package



VS1PF
Pump and Fan Control
LCD English Text Display
Easy to Program
PID Loop with Sleep/Wake
High Horsepower Ratings
Communication Options



Flexible Solutions
Stand alone or multiple
cabinets Inverter, Vector
or Servo
NEMA 1, 3R, 4X or 12
Custom Testing
Matched Motors and Drives

Selection Guide



Power Range	VS1ST — 0.5 to 15 Hp 0.37 to 11 kW					VS1MX — 0.5 to 10 Hp 0.37 to 7.5 kW					VS1MD — 0.5 to 30 Hp 0.37 to 22 kW		VS1PF/PFS— w7.5 to 700 Hp 5.5 to 522 kW		
Voltage	115 1 φ	230 1 φ	230 3 φ	460 3 φ	600 3 φ	115 1 φ	230 1 φ	230 3 φ	460 3 φ	600 3 φ	230 3 φ	460 3 φ	230 3 φ	460 3 φ	600 3 φ
kW Hp															
Enclosure	IP20 Panel Mount					NEMA 12 (IP55) NEMA 4X (IP66)					IP20 Panel Mount NEMA 1 Kit		NEMA 1 (7.5-15 Hp) NEMA 1 Kit (20-125 Hp) or IP00 (150-700 Hp)		
Overload Rating	150% 1 Minute 175% 2 Sec					150% 1 Minute 175% 2 Sec					150% 1 Minute 200% 12 Sec		110% 1 Minute (Normal Duty) 150% 1 Minute (Heavy Duty)		
Ambient Temperature	0 to 50°C					0 to 40° C					-10 to 50° C		-10 to 40° C		
Control Type															
Speed Range	20:1					20:1					30:1		30:1		
V/Hz	✓					✓					✓		✓		
Sensorless Vector	✗					✗					✓		✓		
Closed Loop Vector	✗					✗					✗		✗		
Servo Control	✗					✗					✗		✗		
Standard Features															
Drive Display	LED					LED					LED		LCD Backlit		
Manual Speed Potentiometer	✗					✓					✗		✗		
Custom Display Scaling	Yes					Yes					Yes		Yes		
DB Transistor	2 to 15 Hp (B & C Frames)					2 to 10 Hp (B & C Frames)					Built In		Optional Kit		
Preset Speeds	4					4					8		16		
EMC Filter	Built In Models					Built In Models					✗		○		
Auto Restart	✓					✓					✓		✓		
Energy Savings Mode	✓					✓					✓		✓		
Power-Off Stop	✓					✓					✓		✓		
Inputs and Outputs															
Digital Inputs	2 - Fully configurable 2 - Optional					2 - Fully configurable 2 - Optional					2 - Fully configurable 8 - Fully Programmable		8 - Fully Programmable		
Digital Outputs	1 - Relay, 1 - Optional Digital					1 - Relay, 1 - Optional Digital					1 - Relay, 1 - Opto		5 - Relay		
Analog Inputs	0-10V or 4-20mA					0-10V or 4-20mA					0-10V or ± 10VDC or 0-20mA		0-10V or ± 10VDC or 0-20mA		
Analog Outputs	0-10VDC Multi-function					0-10VDC Multi-function					0-10VDC Multi-function		(2) 0-10V, 0-20 mA kit		
Pulse Train Input	✗					✗					✗		✓		
115VAC Control Logic	○					○					✗		✗		
High Resolution Analog Input Card	✗					✗					✗		✗		
Advanced Features															
PID	✓					✓					✓		✓		
Sleep/Wake	✗					✗					✓		✓		
Draw Control	✗					✗					✓		✗		
Timers & Counters	✗					✗					✓		✗		
PLC Function	✗					✗					✗		✗		
Application Macros	✗					✗					✗		✗		
Positioning Control	✗					✗					✗		✗		
Communications															
Programming Software	CopyCat Loader					CopyCat Loader					DriveView		DriveView		
Modbus - RTU	Standard (RJ45 Port)					Standard (RJ45 Port)					Standard (Terminal)		Standard (Terminal)		
DeviceNet	○ Gateway Head					○ Gateway Head					○		○		
Profibus	○ Gateway Head					○ Gateway Head					○		○		
EtherNet/IP	○ Gateway Head					○ Gateway Head					○		✗		
Modbus TCP/IP	✗					✗					○		○		
BACnet	✗					✗					✗		○		
LonWorks	✗					✗					✗		○		
Metasys N2	✗					✗					✗		○		
ControlNet	✗					✗					✗		✗		
Siemens — P1	✗					✗					✗		○		

Note: ✓ Supported ✗ Not Supported ○ Option Kit ➤ Future Kit



Power Range	VS1SP / VS1GV — 1 to 450 Hp 0.75 to 336 kW				VS1SD — 1 to 100 Hp 0.75 to 75 kW			VS1PM — 1 to 450 Hp 7.5 to 336 kW		Flexible Solutions 1/2 to 1500 Hp
	115/230 1 φ	230 3 φ	460 3 φ	575 3 φ	115/230 1 φ	230 3 φ	460 3 φ	230 3 φ	460 3 φ	
Voltage										
kW Hp	3	60	450	300	3	50	100	10	450	1/3 1500
Enclosure	NEMA 1 (1-500 Hp) NEMA 4X (1-25 Hp) (Indoor)				NEMA 1 NEMA 4X (1-10 Hp) (Indoor)			NEMA 1		NEMA 1, 3R, 4X, 12
Overload Rating	150% 1 Minute 175% 3 Sec				150% 1 Minute 175% 3 Sec			150% 1 Minute 175% 3 Sec		150% 1 Minute 175% 3 Sec
Ambient Temperature	-10 to 45° C				-10 to 45° C			-10 to 45° C		-10 to 45° C
Control Type										
Speed Range	90:1 (VS1SP) 1000:1 (VS1GV)				1000:1			1000:1		1000:1
V/Hz	✓				✗			✓		✓
Sensorless Vector	✓				✗			✗		✓
Closed Loop Vector	✗ (VS1SP) ✓ (VS1GV)				✗			✓		✓
Servo Control	✗				✓			✗		✓
Standard Features										
Drive Display	Graphic LCD				Graphic LCD			Graphic LCD		Graphic LCD
Manual Speed Potentiometer	✗				✗			✗		○
Custom Display Scaling	Yes				Yes			Yes		○
DB Transistor	Built In				Built In			Built In		○
Preset Speeds	15				15			15		Drive Dependent
EMC Filter	✗				✗			✗		✓
Auto Restart	✓				n			✓		✓
Energy Savings Mode	✗				✗			✗		✓
Power-Off Stop	✓				✓			✓		✓
Inputs and Outputs										
Digital Inputs	9 - Fully Programmable				9 - Fully Programmable			9 - Fully Programmable		Drive Dependent
Digital Outputs	2 - Relays, 2 - Optos				2 - Relays, 2 - Optos			2 - Relays, 2 - Optos		
Analog Inputs	± 5VDC, ± 10VDC, 0-10VDC, 4-20 mA and 0-20 mA				± 5VDC, ± 10VDC, 0-10VDC, 4-20 mA and 0-20 mA			± 5VDC, ± 10VDC, 0-10VDC, 4-20 mA and 0-20 mA		
Analog Outputs	± 10VDC or 0 to 20mA				± 10VDC or 0 to 20mA			± 10VDC or 0 to 20mA		
Pulse Train Input	○ (VS1SP) ✓ (VS1GV)				✓			✓		✓
115VAC Control Logic	○				○			○		○
High Resolution Analog Input Card	○				○			○		○
Advanced Features										
PID	✓				✓			✓		✓
Sleep/Wake	✓				✓			✓		✓
Draw Control	✓				✓			✓		✓
Timers & Counters	✓				✓			✓		✓
PLC Function	✓				✓			✓		✓
Application Macros	✓				✓			✓		✓
Positioning Control	⊠ (VS1SP) ✓ (VS1GV)				✓			✓		✓
Communications										
Programming Software	Mint® WorkBench				Mint® WorkBench			Mint® WorkBench		Drive Dependent
Modbus - RTU	Standard (USB Connection)				Standard (USB Connection)			Standard (USB Connection)		
DeviceNet	○				○			○		
Profibus	○				○			○		
EtherNet/IP	○				○			○		
Modbus TCP/IP	○				○			○		
BACnet	○				○			○		
LonWorks	○				○			○		
Metasys N2	○				○			○		
ControlNet	➤				➤			➤		
Siemens — P1	✗				✗			✗		✗

Note: ✓ Supported ✗ Not Supported ○ Option Kit ➤ Future Kit

Baldor Drives Series 5 AC Drive

Analog AC Drive Control

- Power range from 0.5 to 5 Hp
- 115VAC and 230VAC 1-Phase Input
- 230VAC and 460VAC 3-Phase Input
- IP20, NEMA 1 or NEMA 4 (Indoor) Enclosures
- Heavy Duty Rating: 200% Starting Torque
- Volts per Hertz PWM Output
- Analog Control Settings

Looking for a compact size, lower cost inverter? Baldor's Series 5 inverter is all of this and more! Don't let the compact size fool you, the Series 5 micro inverter is packed with protection features found in larger controls. Built-in current limit provides motor overload protection.

Electronic inrush current limit and filtering is standard to reduce transient voltage spikes from dirty power sources. The mounting dimensions are interchangeable to many DC controls and the setup is as easy as turning a screwdriver. We even include the screwdriver.

When space is at a premium in a washdown application, Baldor Series 5 Micro Inverters provide variable torque, constant torque and constant horsepower control in a small package. These controls may be used in new installations, replacements or original equipment. The NEMA 4X enclosure is suitable for frequent washdown and is offered in a black finish or FDA approved white finish. Control features include separate accel/decel rates and controlled reversing. Standard operator control includes rotary speed settings, start/stop command and power on/off. Control is also available in NEMA 1 enclosure.



Compact size and Low Cost

- Microprocessor controlled PWM output
- Accel / Decel Rate Adjustment
- Controlled reversing
- Adjustable Current Limit
- I2t Motor overload protection
- Adjustable Slip Compensation
- Min/Max Output frequency adjustment
- Selectable Auto / Manual Restart

Series 5 Option Accessories

Dynamic Braking Kit ID5RGA-1
Dynamic Braking kit for open chassis
115/230 Volts 1/2 Hp and 1 Hp drives.



Selector Switches

ID5FRS-1 Forward/Stop/Reverse Switch
ID5AMS-1 Auto/Manual Switch

Control switches for the enclosed
Series 5 drives



Compact and Modern Design

Available in Open Chassis, NEMA 1, and NEMA 4X
General Purpose Applications

V/Hz control for Variable Torque, Constant Torque or Constant
Horsepower applications

Built-In LED Power and Status Indicators

Easy Setup with PC board jumpers and adjustable trim
potentiometer

Signal Isolator Kit

ID5SI-1 (IP20 Series 5 Drives)
ID5SI-2 (Enclosed Series 5)

Signal isolator for open and enclosed units.
Provides isolation for up to 24 VDC and
4-20mA command signals.



Baldor Drives VS1SM Single-Phase AC Microdrive

230VAC Single Phase EMC Drive

- Power range from 0.5 to 3 Hp
- 230VAC 1-Phase Input
- IP20 Enclosure
- Heavy Duty Rating: 150% Overload
- Volts per Hertz or Sensorless Vector
- Built in Speed Potentiometer
- Easy to use operator interface
- RS485 Serial Modbus-RTU interface
- Internal EMC Filter Model

VS1SM is a dedicated single phase 230 Volts AC Microdrive designed for OEM applications. Available up to 3 HP, this unit can be supplied with or without an internal EMC filter. Its compact size, user-friendly interface, and superior motor torque make it ideal for a wide variety of applications.

Common Control Modes

VS1SM has two control modes to cover basic pump and fan or high performance applications. The auto tuning algorithm automatically sets motor parameters to simplify startup of the controller.

Volts per Hertz Control

VS1SM drive uses traditional inverter V/Hz control method with linear, fan/pump or custom curves. Its easy setup, quick start, and right out-of-the-box operation make it among the most popular variable speed motor controls.

Sensorless Vector Control

VS1SM can also function in a sensorless vector mode for constant torque applications.

PID Loop Control Modes

In centrifugal pump and fan applications, PID control is provided as a standard function, helping maintain a constant process control of pressure, flow and oil level. This function includes pre-PID, sleep/wake, and output inverse sub-functions.



Easy to Use Interface

The keypad on the VS1SM microdrive incorporates one-finger up/down, left and right arrows to help you navigate effortlessly. The built in run, stop/reset and manual speed potentiometer makes running the drive from the keypad a breeze.

Simple to Program

Parameters are arranged by groups for easy navigation and startup. The basic group of parameters is all that need be setup for general purpose applications.

RS485 Serial Port

Every VS1SM comes standard with an integral RS485 Serial Port, Modbus RTU for basic programming and configuration using DriveView software. A standard serial network can also be configured using this connection.

Global Standard

Built-In EMC Filter

For applications that an EMC Filter is required (common for applications in European markets) to reduce line noise, the VS1SM is available with an internal filter. This reduces the foot print of the drive when compared to units that require external devices.

Baldor Drives

VS1ST AC Drive

General Purpose Panel Mount Drive with Performance Features

- Power range from 0.5 to 15 Hp
- 115VAC and 230VAC 1-Phase Input
- 230VAC and 460VAC 3-Phase Input
- 600VAC 3-Phase Input (STS)
- IP20 Panel or DIN rail mounting
- Heavy Duty Rating, 150% Overload
- Feed through power wiring
- Easy to use keypad
- Versatile I/O configurations
- RS485 Serial Modbus-RTU port
- Field pluggable option cards

Baldor's VS1ST Drive is a feature rich Volts per Hertz product designed for use by equipment manufacturers. Combining performance with an intuitive operator interface, the drive can be started up after adjusting just a few basic parameters.

Easy to use Keypad

The VS1ST microdrive's convenient interface allows for simple parameter setup. Built in local control allows this drive to operate out-of-the-box.

Ready to Run Out-of-the-Box

Designed to replace fix speed motor starters, the VS1ST uses a traditional V/Hz control method. It is easy to setup and has only forty five parameters for quick startup.



Quick Reference Card

Each drive comes with a help card that shows basic wiring and drive setup parameters.

Basic Programming and Setup

The VS1ST drive uses just ten of the forty five parameters for a basic startup. The keypad is intuitive and is used for both programming as well as local operator control.

Built-In Communications

With its built-in RS485 ModBus-RTU, the VS1ST can communicate with ease to other devices.

CopyCat Loader

Duplicate drive settings quickly and efficiently with the handy copycat loader. Upload software parameters from one drive and then download later or duplicate settings across a number of units.

Technical Data

Single Phase Input AC Supply	115 VAC: 0.5 to 1.5 Hp (0.37 to 1.1 kW) 230 VAC: 0.5 to 3 Hp (0.37 to 2.2 kW)
Three Phase Input AC Supply	230 VAC: 0.5 to 5 Hp (0.37 to 4 kW) 460 VAC: 1.0 to 15 Hp (0.75 to 11 kW) 575 VAC: VS1STS (contact Baldor)
Enclosure Rating	IP20 Panel or DIN Rail Mounting
Control and Speed Range	Enhanced Volts per Hertz, 20:1 Operating Speed Range
Operator Interface	LED Display; six character Hertz, Amps, Motor RPM or Custom Units Local Control Start/Stop, Forward/Reverse, Speed Increase/Decrease Control Programming Operational Parameters
Software Features	Power – Off E-Stop, DC injection braking, Power line dip ride through, Skip frequency, Software parameter lock, Display speed scaling, PID control, Auto restart, Slip compensation, Energy savings features
Communications	Modbus-RTU, built in RJ45 port

Easy to Install

Pull Apart Terminal Strip

Every VS1ST drive has pull-apart terminal strips for easy installation and replacement. Simply remove the terminal strip to retrofit the drive unit, no re-wiring required.

DIN Rail Mounting

Frames A and B come standard with DIN Rail mounting capability, simply snap the drive into place.

Feed Through Power Wiring

The VS1ST is ideal for replacement of fixed speed motor starters. Power wiring comes into the top of the drive and out to the motor from the bottom. Separate ground connections are provided for both incoming as well as outgoing power.

Advanced Capabilities

PI Control

PI control is provided as a standard function, helping maintain a constant process control of pressure, flow and level in pump and fan applications. This function includes PI reference selection.

Energy Savings Mode

The drive automatically reduces the applied motor voltage depending on the load conditions. This type of control produces a higher starting torque over a typical variable torque speed curves.

Power-Off Braking

If power is lost to the drive, the VS1ST can use the energy stored in the mechanical system. Regenerated power is used to keep the drive active and bring the motor to a stop under a controlled condition.

Internal Brake Transistor

When applications require fast stopping times or response, the VS1ST has built in braking capability for frames B and C. The resistor kit used to absorb braking energy fits internal to the drive.

Typical Industries

- Material Handling
- Food Processing
- Waste Water
- Packaging
- Chemical
- Pumping
- HVAC



EMC Filter and VAR Protection

Standard model number drives are available with a built in EMC filter for European compliance. All drives come standard with input supply voltage surge suppression components fitted to protect the drive from line voltage transients, typically originating from lightning strikes or switching of high power equipment on the same supply.

EMC and VAR Protection can be removed from the circuit with a simple screw connection when earth leakage current is too high, for floating supplies or in cases flash testing (HiPot) is needed.

Technical Data

Digital Input 1 & 2	Fully Configurable, Factory set to common defaults, 24VDC control logic
Digital Input 3 / Analog Input 2	Configurable for motor thermistor input, Programmable as Analog Input 2 (0-10V or 4-20mA)
Analog Input 1 / Digital Input 4	0-10V or 4-20mA, Programmable as Digital Input 4
Relay Output	Normally Open Contact
Analog Output / Digital Output	0-10V, Programmable as Digital Output
Environmental	0 to 50 Deg C Ambient, 3300 Feet (1000m) Altitude, 10 to 95% Humidity (non-condensing)
Electrical	115/230/460VAC @ 50/60 Hz, 97% Efficiency at full load and frequency
Output Ratings	150% for 1 minute, 175% for 2 seconds Current Rating, 0 to 500 Hz Output Frequency, 4 to 32 kHz Carrier

Baldor Drives VS1MX AC Drive

NEMA 4X (IP66) Washdown and NEMA 12 (IP55) Dust Tight Harsh Duty Drive

- Power range from 0.5 to 10 Hp
- 115VAC and 230VAC 1-Phase Input
- 230VAC and 460VAC 3-Phase Input
- 600 Volt 3-Phase Input (XMS)
- Resists water, dust and chemicals
- Heavy Duty Rating, 150% Overload
- Easy to use keypad
- Optional Local Control and Disconnect
- Versatile I/O configurations
- RS485 Serial Modbus-RTU port
- Field pluggable option cards

Baldor's VS1MX Drive is a feature rich Volts per Hertz product designed for use in Harsh Duty environments. Available as a switched version with a built in input disconnect, on/off switch and speed potentiometer, this drive is ideal for stand alone applications.

Easy to use Keypad

The VS1MX microdrive's convenient interface allows for simple parameter setup. Built in local control allows this drive to operate out-of-the-box.

Switched Units

Model number drives are available with local operator controls including a local potentiometer for speed control, a forward/off/reverse run switch, and a built in lockable disconnect switch.



Ready to Run Out-of-the-Box

Designed for stand alone applications, the VS1MX uses a traditional V/Hz control method. It is easy to setup and has only forty five parameters for quick startup.

Basic Programming and Setup

The VS1MX drive uses just ten of the forty five parameters for a basic startup. The keypad is intuitive and is used for both programming as well as local operator control.

Built-In Communications

With its built-in RS485 ModBus-RTU, the VS1MX can communicate with ease to other devices.

CopyCat Loader

Duplicate drive settings quickly and efficiently with the handy copycat loader. Upload software parameters from one drive and then download later or duplicate settings across a number of units.

Technical Data

Single Phase Input AC Supply	115 VAC: 0.5 to 1.5 Hp (0.37 to 1.1 kW) 230 VAC: 0.5 to 3 Hp (0.37 to 2.2 kW)
Three Phase Input AC Supply	230 VAC: 0.5 to 5 Hp (0.37 to 4 kW) 460 VAC: 1.0 to 15 Hp (0.75 to 11 kW) 575 VAC: VS1MXS 1 to 7.5 Hp (contact Baldor)
Enclosure Rating	NEMA 4X (IP66) or NEMA 12 (IP55) VS1MXS 1 to 7.5 Hp (contact Baldor)
Control and Speed Range	Enhanced Volts per Hertz, 20:1 Operating Speed Range
Operator Interface	LED Display; six character Hertz, Amps, Motor RPM or Custom Units Local Control Start/Stop, Forward/Reverse, Speed Increase/Decrease Control Programming Operational Parameters
Software Features	Power – Off E-Stop, DC injection braking, Power line dip ride through, Skip frequency, Software parameter lock, Display speed scaling, PID control, Auto restart, Slip compensation, Energy savings features
Communications	Modbus-RTU, built in RJ45 port

Washdown Ratings

NEMA 12 (IP55)

This rating drive is intended for industrial indoor use, providing protection against dust, falling dirt and dripping non-corrosive liquids.

NEMA 4X (IP66) (Indoor)

Suitable for high pressure washdown applications, the drive is protected from hose-directed water. A high pressure form fit cover seals the enclosure from both water and dust.

Corrosion Resistant

Designed for mounting right out on the plant floor, NEMA4X (IP66) drives use the highest performance epoxy electrocoat system to protect the heatsink. This process provides excellent edge coverage and corrosion resistance in harsh washdown environments.

Advanced Capabilities

PI Control

PI control is provided as a standard function, helping maintain a constant process control of pressure, flow and level in pump and fan applications. This function includes PI reference selection.

Energy Savings Mode

The drive automatically reduces the applied motor voltage depending on the load conditions. This type of control produces a higher starting torque over a typical variable torque speed curves.

Power-Off Braking

If power is lost to the drive, the VS1MX can use the energy stored in the mechanical system. Regenerative power is used to keep the drive active and bring the motor to a stop under a controlled condition.

Internal Brake Transistor

When applications require fast stopping times or response, the VS1MX has built in braking capability for frames B and C. The resistor kit used to absorb braking energy mounts external to the drive.

Built-In Disconnect Switch

Standard model number drives are available with local operator controls (speed potentiometer and a reverse-off-forward run switch) and a built in lockable disconnect switch.

Typical Industries

- Food & Beverage
- Waste Water
- Chemical
- Conveyor
- Pumping
- Bottling
- Baking



Technical Data

Digital Input 1 & 2	Fully Configurable Factory set to common defaults 24VDC control logic
Digital Input 3 / Analog Input 2	Configurable for motor thermistor input Programmable as Analog Input 2 (0-10V or 4-20mA)
Analog Input 1 / Digital Input 4	0-10V or 4-20mA Programmable as Digital Input 4
Relay Output	Normally Open Contact
Analog Output / Digital Output	0-10V Programmable as Digital Output
Environmental	0 to 50 Deg C Ambient 3300 Feet (1000m) Altitude 10 to 95% Humidity (non-condensing)
Electrical	115/230/460VAC 50/60 Hz 97% Efficiency at full load and frequency
Output Ratings	150% for 1 minute 175% for 2 seconds Current Rating 0 to 500 Hz Output Frequency 4 to 32 kHz Carrier
Option Kits	DB Resistor (Frames B & C) Relay Output Card 110 or 230V Control Input Card Remote Keypad CopyCat Loader Communication Gateways (DeviceNet, EtherNet/IP or Profibus) Serial Network Cables

Flexible Solutions

VS1ST & VS1MX Modular Enhancements

Application flexibility is key; option kits provide solutions when additional features are required. Expanded input/output modules and high voltage control logic are simple to obtain using a plug in card. Dynamic braking resistors fit internal to the drive to simplify installation and reduce mounting space requirements. Networking cables allow connection to a process controller for drive operation and status information.

CopyCat Keypad

VS1ST-CCL

This handy device allows rapid upload of drive parameters. Simply insert the device into the RJ45 port on the front of the VS1ST or VS1MX, and press the upload button.



Parameters are stored and can be downloaded later or used to duplicate drive setup across a number of drives.

Remote Keypad

VS1ST-RKEY3

The Remote Keypad for the VS1ST and VS1MX drives can be used to program or control the operation of the units. Keypads are designed to operate real time and mimic the main drive display.



Simply assign the node drop number of the desired drive, and the keypad will connect automatically.

IP54 rated when panel mounted, keypads feature a bright LED Display, membrane keypad, parameter lock function and a 9 foot (3 meter) cable.



Network Gateways

Ideal for factory, building and process automation industries

Communication Gateways are available to interface the Modbus-RTU Network to DeviceNet EtherNet/IP and Profibus. The communicator performs an intelligent conversion between the serial protocol and the chosen industrial network. Gateway modules function with both the VS1ST or VS1MX.

VS1ST-DNET DeviceNet Gateway

VS1ST-PBUS Profibus Gateway

VS1ST-ENET EtherNet/IP Gateway

Gateways come standard with a 3 foot (1 meter)

Network Cables

To compliment the Communication Gateways and Remote Keypad, a series of network cables are available. Splitter modules are used to connect multiple drives or keypads together.

VS1ST-J45SP RJ45 Splitter Cable

VS1ST-CBL0P5 1.5 ft. (0.5m) RJ45 Cable

VS1ST-CBL1 3 ft. (1m) RJ45 Cable

VS1ST-CBL3 5 ft. (3m) RJ45 Cable



Expanded I/O Plug-In Cards

To handle applications that require additional relay outputs, expanded I/O cards are available. These cards simply plug into the standard terminal.

VS1ST-2ROUT Relay Output Card

The 2ROUT module replaces the standard Analog Output with a 2nd fully programmable Relay Output contact.

VS1ST-HVAC Dual Relay Output Card

The HVAC module provides 2 Dedicated Relay Outputs for “drive running” and “drive tripped” while maintaining all of the standard control terminal connections.



High Voltage Logic Cards

This option module is designed to allow the digital inputs of the drive to be controlled directly from a 115 Volt or 230 Volt control supply without the need for interfacing relays.

VS1ST-LOGHV-11 115V Control Voltage Input Card

VS1ST-LOGHV-23 230V Control Voltage Input Card

The existing analog input on the VS1ST can still be used, by connecting the analog signal input on terminal 6, or alternatively a fourth 110 / 230VAC digital input can be connected via the removable plug. All other inputs and outputs to the drive are not affected.

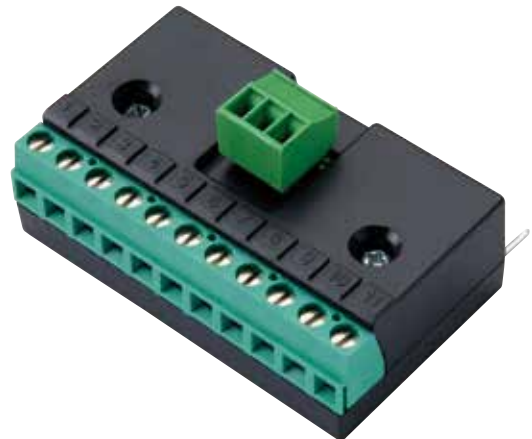

VS1MX Disconnect Locking Device

Locking Device for the VS1MX

VS1MX-ILOCK Padlock fitted to VS1MX Disconnect

Dynamic Braking Resistors

Available on 2 Hp or higher (Frames B & C), resistors are for use for high inertia loads that require rapid stopping times. Braking energy is managed by the drive and converted to heat energy.

VS1ST-R100W200 100 ohm, 200 watt

VS1MX-R50W200 50 ohm, 200 watt

Software in the drives protects these resistors from overload; while a built in fusible element ensures fail safe operation.

Resistors are IP21 rated in a metal clad housing. No space penalty is needed as resistors are designed to mount internal to the VS1ST or to the side of the VS1MX heatsink.



General Purpose Panel Mount Drive with Performance Features

- Power range from 0.5 to 30 Hp
- 230VAC and 460VAC 3-Phase Input
- IP20 Enclosure (NEMA 1 / DIN rail kits)
- Heavy Duty Rating: 150% 1 minute, 200% 12 sec overload
- Internal brake transistor
- Easy to use keypad
- Versatile I/O configurations
- RS485 Serial Modbus-RTU interface
- Communication option cards

With capability up to 30 Hp, Baldor's VS1MD Drive is among the most powerful cost competitive drives in its class. Compact in size, user friendly interface, rich range of option kits, and superior motor torque are what make this product ideal for a wide range of applications.

Easy to use Interface

The VS1MD microdrive's convenient interface utilizes four directional keys for simple setup. Parameters are arranged in groups for Basic Startup, I/O Setting, Functional and Advanced Parameters. This allows fast and easy access to just the settings required for your application.

Ready to Run Out-of-the-Box

Basic applications can be set up using just fifteen parameters. Parameters consist of common motor setup values, acceleration and deceleration ramps, min/max speed, speed reference source and control source selection.



Advanced Control Modes

The VS1MD has multiple control modes to fit any process. Default is volts per hertz operation, and sensorless vector can be selected for increased speed accuracy. For advanced process control the drive also incorporates PID and Draw control loops.

Communications Capabilities

With its built-in RS485 ModBus-RTU, the VS1MD can communicate with ease to other devices. Expansion cards are also available to allow interface to common industrial networks such as DeviceNet, Profibus and Ethernet.

CopyCat Keypad and Software Tools

Duplicate drive settings quickly and efficiently with the copycat keypad. Upload software parameters from one drive and then download later or duplicate settings across a number of units.

DriveView software is available to program the drive from a conventional personal computer.

Technical Data

Three Phase Input AC Supply	230 VAC: 0.5 to 30 Hp (0.37 to 22 kW) 460 VAC: 0.5 to 30 Hp (0.75 to 22 kW)
Enclosure Rating	IP20 Panel Mount
Enclosure Options	NEMA 1 or DIN Rail Mounting Kit
Control and Speed Range	Enhanced Volts per Hertz or Sensorless Vector 30:1 Operating Speed Range
Operator Interface	LED Display; four character, hertz or parameter selected display value Local Control Start/Stop, Forward/Reverse, Speed Increase/Decrease Control Programming Operational Parameters
Software Features	Power – Off E-Stop, DC injection braking, PID Control with Sleep/Wake, Draw Control, Timers, MOP Reference, Local/Remote Control, Jog forward/Reverse, Skip frequency (3), Preset Speeds (8), Software parameter lock, Display speed scaling, Auto restart, Slip compensation, Energy savings mode, Electronic brake control
Communications	Modbus-RTU, S+ S- Terminal Connection
Communications Options	DeviceNet, Profibus, EtherNet/IP and Modbus TCP/IP

Advanced Control Features

Power-Off Braking

If power is lost to the drive, the VS1MD can use the energy stored in the mechanical system. Regenerated power is used to keep the drive active and bring the motor to a stop under a controlled condition.

Internal Brake Transistor

All drive ratings come standard with an internal braking transistor.

Draw Control

This function allows the user to set a speed reference and then adjust it with a second analog input for trim. Useful in tension control systems or applications requiring the drive to run at some percentage of the main line speed.

Timer Functions

For applications that require a function to occur after a set amount of time, the VS1MD has input timers that can sequence a digital output. Additional on/off delays can be set for the relay and digital output.

2nd Motor Operation

With this feature, the drive is able to operate two motors connected to different types of loads. Simply input information on the second motor and then use a digital input to switch.

Energy Savings

With its energy savings features, the VS1MD automatically adjusts output based on load conditions. Or, the manual mode allows for fine tuning based on the application.

PID Control

In pump and fan applications, PID control helps maintain a constant process control of pressure, flow and level. This function includes pre-PID, sleep/wake, and PID reference selection.

PID Sleep / Wake

This function disables/re-enables the drive automatically as demand dictates. Unnecessary operation is eliminated at idle speeds, saving wear and tear on the mechanical system as well as energy consumed by the drive.

Energy Savings Mode

The drive automatically reduces the applied motor voltage depending on the load conditions. This type of control produces a higher starting torque over a typical variable torque speed curve.



Cooling Fan Control

When the drive is not in operation, the cooling fan can automatically turn off, reducing energy consumption as well as wear and tear on the fan.

Typical Industries / Applications

- Material Handling / Conveyors
- Food Processing Equipment
- Packaging Machines
- Mixers / Agitators
- Pharmaceutical
- Pumps / Fans
- Aggregate
- Bottling

Technical Data

Digital Inputs (8)	Fully Configurable, Factory set to common defaults, 24VDC control logic
Digital Output	Optically Isolated Output
Relay Output	Normally Open Contact or Normally Closed Contact
Analog Inputs (2)	0-10V or -10 to 10V, 4-20mA, 10 bit resolution
Analog Output	0-10V, Proportional to frequency, current, voltage or dc voltage, 10 bit resolution
Environmental	-10 to 50 Deg C Ambient, 3300 Feet (1000m) Altitude, 10 to 95% Humidity (non-condensing)
Electrical	230/460VAC, 50/60 Hz, 97% Efficiency at full load and frequency
Output Ratings	150% for 1 minute, 200% for 12 seconds Current Rating, 0 to 400 Hz Output Frequency, 1 to 15 kHz Carrier
Option Kits	DB Resistor (Frames B & C), Relay Output Card, 110 or 230V Control Input Card, Remote Keypad, CopyCat Loader Communication Gateways (DeviceNet or Profibus), Serial Network Cables

Flexible Solutions

VS1MD Modular Enhancements

Application flexibility is key; option kits provide solutions when additional features are required. Communication Network cards can interface the VS1MD to a PLC systems using a simple plug in card. Software setup is a snap using the complimentary DriveView Software Programming package or the CopyCat handheld keypad. From stand alone control to integrated network process line solutions, the VS1MD is flexible enough to meet your application requirements.

Remote Keypad

VS1MD-RKEY2, -RKEY3 or -RKEY5

The Remote Keypad can be used to program or control the operation of VS1MD units. Keypads are designed to operate real time and mimic the main drive display. Simply assign the node drop number, and the keypad will connect automatically to that drive on the network.

Keypads feature a bright LED Display, membrane keypad, parameter lock function and come standard with either a two, three or five meter cable.

CopyCat Keypad

VS1MD-CCL

This device allows uploading of drive parameters. Functioning the same as the Remote Keypad, it comes total enclosed for hand held use. Parameters are stored in memory and can be used to duplicate drive setup across a number of units.



Communication Networks

Ideal for factory, building and process automation communication cards are available for DeviceNet and Profibus.

VS1MD-DNET DeviceNet Option Card

VS1MD-PBUS Profibus Option Card

VS1MD-ENET EtherNet IP / ModbusTCP/IP Option Card

Network cards fit internal to the VS1MD drive replacing the standard operator interface and control board. A base unit drive ready to install the appropriate card is used. Overall dimensions of the drive are not affected by adding a network card.

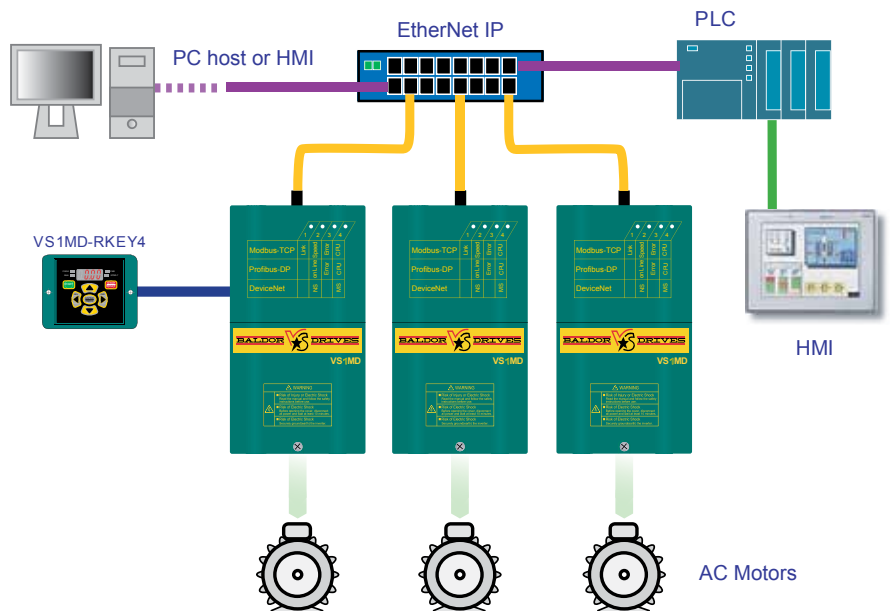

DIN Rail Mounting Kit

VS1MD-DINA, -DINB, -DINC

This option module is designed to allow the drive to be DIN rail mounted. Frames A, B and C up to 5 Hp can be converted to DIN rail. Additionally these drives are of equal frame height making lineups in a cabinet uniform.



NEMA 1 Mounting Kit

VS1MD-NM1A, -NM1B, ... -NM1F

Converting the VS1MD to NEMA 1 for wall mounting is as easy as installing a conduit kit. All ratings up to 30 Hp can be converted by simply selecting the correct frame size option.

DB Resistor Kit

Braking: VS1MD drives include built-in braking transistors to aid in stopping loads rapidly. External braking resistors are used to convert the regenerative energy to heat energy.

Resistors: Designed for separate mounting and include a temperature device as standard to shut down in case of an overload condition. Available in a wide range of sizes from 200 to 1200 Watts, they can handle typical applications that require intermittent braking.



RS485 programming Cable

This kit connects a personal computer to the drive. It includes a USB cable, converter module and RS485 serial connection for the drive.

VS1-COMMUSB USB to RS-485 Serial Converter Cable Kit



DriveView Programming Software

Baldor provides a free tool to setup, change and view parameters. DriveView provides functions for:

- On-line and Off-line Parameter Editor
- Real Time Keypad Control
- Upload / Download Fault History With Time Stamp
- Running Status / I/O Information
- File Reporting
- Oscilloscope Function

Drive programming software can be downloaded for free at:
www.baldor.com

Baldor Drives VS1PF AC Drive

Pump and Fan Drive with Energy Savings Features

- Power range from 7.5 to 700 Hp
- 230VAC, 460VAC & 600VAC 3-Phase Input
- NEMA 1 or IP00 Enclosure
- Pump and Fan Rating: 110% Overload
- Volts per Hertz or Sensorless Vector
- Easy to use keypad
- Versatile I/O configurations
- RS485 Serial Modbus-RTU interface
- HVAC communication option cards

Baldor's VS1PF Drive is a feature rich AC drive for the pump and fan markets or general purpose applications. The VS1PF provides traditional energy savings by controlling centrifugal loads with a variable frequency drive. Unique algorithms further reduce energy consumed by your application. The drive can be started up after adjusting just a few basic parameters.

Pump and Fan Features

The VS1PF has built-in features for pump and fan applications:

- External and Internal PID control
- Sleep/Wake functions for system standby energy savings
- Motor pre-heat to eliminate motor condensation
- Flying start to catch rotating loads
- Automatic energy savings mode

Communication Capabilities

With its built-in RS485 ModBus-RTU, the VS1PF can communicate with other devices. Expansion cards allow interface to common industrial networks and HVAC building protocols.



PID Loop Control Modes

PID control helps maintain a constant process control of pressure, flow and level in centrifugal pump and fan applications. This function includes pre-PID, sleep/wake, and output inverse sub-functions.

External PID

This function can be used to regulate an external process, such as a temperature loop. It can also provide cascaded control to the internal PID, or directly control the motor speed.

Internal PID

This regulates process variables, and the drive's internal PID control function can receive references from an analog input, keypad, or communications port. In addition, it can receive process feedback via an analog or pulse input.

Technical Data

Three Phase Input AC Supply	230 VAC: 7.5 to 40 Hp (5.5 to 30 kW) VS1PFS 50 to 75 Hp (37 to 55 kW) 460 VAC: 7.5 to 700 Hp (5.5 to 522 kW) 600 VAC: 7.5 to 150Hp (5.5 to 110kW)
Enclosure Rating	NEMA 1 (7.5 to 15 Hp), NEMA 1 Kit (20 to 125 Hp), IP00 Panel Mount (150 to 700 Hp)
Control and Speed Range	Enhanced Volts per Hertz or Sensorless Vector, 30:1 Operating Speed Range PID Control Loop (External and Internal), Sleep / Wake Function
Operator Interface	0-10V or -10 to 10V, 4-20mA, 10 bit resolution
Analog Output	LED Display; six character Hertz, Amps, Motor RPM or Custom Units, Local Control Start/Stop, Forward/Reverse, Speed Increase/Decrease Control, Programming Operational Parameters
Software Features	Power – Off E-Stop, DC injection braking, PID Control with Sleep/Wake, MOP Reference, Local/Remote Control, Jog Forward/Reverse, Skip frequencies (3), Preset Speeds (16), Software parameter lock, Custom Display Screens (7), Auto restart, Slip compensation, Energy savings mode, Electronic brake control
Communications	Modbus-RTU, Terminal Connection
Communications Options	DeviceNet, Profibus, Modbus TCP/ IP, BACnet, LonWorks, Metasys N2, Siemens-P1 (Ext opt. Kit)

User Friendly Interface

The keypad on the VS1PF drive is simple to operate, easy to program and convenient to monitor. It features nine keys and an easy to read graphic LCD display. The backlit display is text-based providing easy to read and understand status information.

Text Display: Operator interface, programming steps and help files are in English text, there are no codes to figure out and understand. Text can be reformatted for foreign languages or in larger font sizes.

Monitoring Screens: Seven operating displays can be accessed simply by pressing the SEL key.

Upload/Download: Keypads have a built-in upload/download copycat capability.

Easy Field Wiring

Not only is the VS1PF easy to program, installation is simplified with the features standard to the drive. Pull apart terminal connections make control wiring a snap. Motor terminals are generously sized and clearly labeled for power connections. Cooling fans are also designed to be field replaceable.

Enhanced Control Modes

Safety / Controlled Stop

Better management during a power line dip or power-off condition is enabled with this feature. It lets you program the drive to automatically slow down the load during these conditions. The drive can remain active by recovering the inertial energy in the rotating load until the motor reaches zero speed.

Drive Temperature Adaptation

With this feature, the drive alters the carrier frequency when the ambient temperature increases above normal, allowing continued operation under adverse conditions.

Flux Braking

By over-fluxing the motor during deceleration, flux braking lets you stop the load quickly – thus transferring the rotational energy of the load to heat in the motor for greater efficiency.



Typical Industries / Applications

- Batch, Flow & Pressure Regulation
- Pump and Air Handling
- Waste Water Treatment
- Aggregate and Mining
- Packaging Machines
- Mixers / Agitators
- Food Processing
- Conveyors

Technical Data

Digital Inputs (8)	Fully Configurable, Factory set to common defaults, 24VDC control logic
Relay Outputs (5)	Normally Open or Normally Closed Contacts
Analog Inputs (2)	0-10V or -10 to 10V, 4-20mA
Analog Outputs (2)	0-10V
Environmental	-10 to 40 Deg C Ambient, 3300 Feet (1000m) Altitude, 10 to 95% Humidity (non-condensing)
Electrical	230/460VAC, 50/60 Hz, 97% Efficiency at full load and frequency
Output Ratings	110% for 1 minute (Normal Duty), 150% for 1 minute (Heavy Duty) Output Current Rating, 0 to 400 Hz Output Frequency, 1 to 15 kHz Carrier

Baldor Drives

VS1PF Bypass

VS1PF Bypass

Pump and Fan Packaged Drive

- Power range from 7.5 to 700 Hp
- 230VAC, 208VAC and 460VAC 3-Phase Input
- NEMA 1 Enclosure
- Pump and Fan Rating: 110% Overload
- Volts per Hertz or Sensorless Vector
- Easy to use keypad
- Versatile I/O configurations
- RS485 Serial Modbus-RTU interface
- HVAC communication option cards

The VS1PF pump and fan package meets typical HVAC specification requirements. Industry standard features such as a Circuit Breaker, Lockable Disconnect, Hand-Off-Auto (HOA) and Local/Remote Bypass are provided

Utilizing an Integrated Electronic Bypass Module, the VS1PFB can automatically switch to bypass when a fault occurs on the Drive. The standard control station includes a Speed pot for operating, Hand/Off/Auto Switch and an ASD/Bypass/Test Switch for ease of control. LED indicating lights are provided for Power Indication, ASD Mode, Bypass Mode or Fault.

Slim line design allows for side-by-side mounting with near zero clearance. For quick connections and startup, all controls are pre-wired with knock-outs for line, load and control signals.

Performance HVAC Features

Multi-Motor Control

When the process demands increased flow or volume, the VS1PF PID Loop can automatically bring on additional motors to handle the load.

Current Leakage Reduction

HVAC applications encounter damp conditions. The VS1PF uses a multilevel PWM algorithm to reduce the amount of current leakage to ground and therefore the chance that the drive will trip. The VS1PF is fully earth-leakage protected eliminating the potential for a catastrophic drive failure; even while running.

Bypass Control Module

Indicating Lights

Convenient status LEDs display status of the bypass control, power and drive condition:

Power On Light - Amber

ASD - On (ASD is controlling motor)

Bypass

- On when in normal bypass
- Slow blinking (remote command source or drive)

Fault

- On when ASD is faulted
- Slow blinking when critical fault

Control Switches

The VS1PF has built in features for standard HVAC applications and also includes advanced controls such as:

Speed - Reference in Hand Mode

Hand - Off - Auto Switch

- Hand Mode speed from potentiometer
- Off shuts down the motor
- Auto selects process line control signal

ASD - BYP - TEST

- ASD places the Drive in operation
- Bypass selects motor across the line
- Test mode allows the control to be on and programmed while in Bypass mode.

Power Monitor

This feature displays both instantaneous and accumulated energy as they are being used by the system.

Pre-Heat

This allows the drive to maintain residual heat in the motor, which helps eliminate condensation in damp conditions when the motor is not in use. In the drive, an adjustable, low-level DC current is applied to the stator windings either continuous or on a duty cycle.



Flexible Solutions

VS1PF Performance Features and Modular Enhancements

Application flexibility is key and providing industry solutions for the variable torque pump and fan markets is the core design of the VS1PF. Industry specific features are built into the product and applications enhancement cards are available. Communication Network cards focused on the HVAC market can interface the VS1PF to the building automation system. Flexible mounting options allow installation in multiple configurations, you decide. Software setup is a snap using the complimentary DriveView Software Programming package. From stand alone control to integrated network process line solutions, the VS1PF is flexible enough to meet your application requirements.

Significant Energy Savings

With its energy savings features, the VS1PF drive provides costs savings over traditional damper control systems.

PID Sleep / Wake

The sleep/wake function disables and re-enables the drive automatically as demand dictates. This function is helpful by eliminating unnecessary operation at idle speeds' saving mechanical wear and tear plus energy.

Flying Start

Many applications may have back-pressure causing a pump to spin backwards or updrafts in the ventilation shaft resulting in a fan rotating while the drive is idle. Flying start allows the VS1PF to accelerate into the rotating load.

Automatic Energy Savings

In automatic mode, output is dynamically adjusted by the drive based on load conditions for optimized savings. Or, the manual mode allows for fine tuning based on the application.

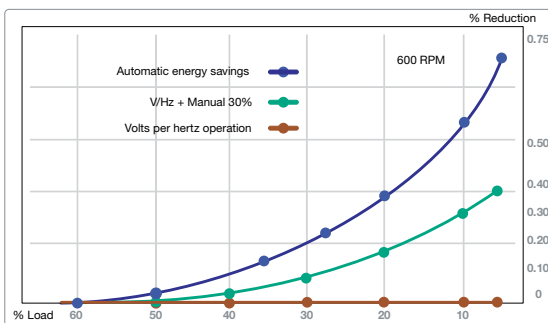

Network Solutions

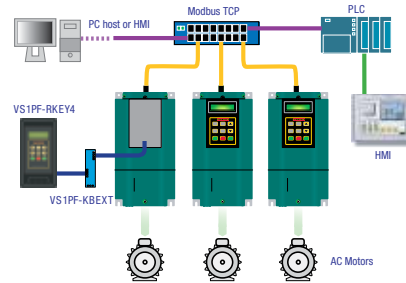

Remote Keypad VS1PF-RKEYN4

The keypad can program or control the operation of the drive. Keypads mimic the main drive display. Panel mounted in a NEMA 4X housing, keypads feature a bright LCD Display. An extended cable kit, can increase the distance at which the remote keypad can be mounted, up to 4,000 feet maximum.

Communication Networks

Ideal for factory, building and process automation industries, communication cards are available for DeviceNet & Profibus. Future releases include Modbus TCP/IP, BACnet, LonWorks & Metasys N2.

VS1PF-DNET	DeviceNet
VS1PF-PBUS	Profibus
VS1PF-MBTCP	ModbusTCP/IP
VS1PF-BAC	BACnet
VS1PF-LON	LonWorks
VS1PF-MET	MetaSys N2
VS1PF-P1B	Siemens-P1-Ext. Opt. Kit.



DriveView Programming Software

Baldor provides a free tool to setup, change and view parameters. DriveView provides functions for:

- On-line and Off-line Parameter Editor
- Real Time Keypad Control
- Upload / Download Fault History With Time Stamp
- Running Status / I/O Information
- File Reporting
- Oscilloscope Function

Programming software can be downloaded at: www.baldor.com

RS485 Programming Cable VS1-COMMUSB

Connecting from a personal computer is as simple as a USB port and two wires by using the communication cable kit. This kit provides a USB cable, converter module and RS485 serial connection for the drive.

Baldor **V*S** Drives VS1SP & VS1GV AC Drives

High Performance AC Vector Control

- Power range from 1 to 500 Hp
- 115VAC and 230VAC 1-Phase Input
- 230VAC, 460VAC & 575VAC 3-Phase Input
- NEMA 1 or NEMA 4X Enclosure
- Heavy Duty Rating: 150% Overload
- V/Hz, Sensorless or Closed Loop Vector
- Easy to use operator interface
- Flexible I/O configurations
- RS485 Serial Modbus-RTU interface
- Versatile option cards

The VS1SP and VS1GV High-Performance AC drives are built on Baldor's H2 technology. With their powerful processor and advanced design features, Baldor V*S Drives provide high performance control of your application. These drives are also simple to program and easy to operate. Their removable keypads provide quick help text information in the language of your choice.

VS1SP Sensorless Vector AC Drive

Baldor's VS1SP Drive uses a traditional V/Hz control method. With its easy setup this is most popular of variable speed motor control. It is ideal for applications where multiple motors are operated simultaneously from one motor control, including most industrial applications.



Sensorless Vector Control Open-Loop Speed / Current Control

For single motor operation, the VS1SP drive supports sensorless vector control, which allows better speed and current control without the concerns of additional wiring and setup. It is particularly effective for high performance, open loop applications.

Sensorless Vector Advantages

- Low-speed operation
- Good motor current control

VS1GV Closed Loop Vector AC Drive

Baldor's VS1GV Vector Drive offers three modes of control: Closed-Loop Vector, Sensorless Vector, or the traditional V/Hz method.

Closed-Loop Vector Ultimate Control

The closed-loop vector method provides the ultimate control of AC induction motors. Using a motor-mounted encoder, it precisely controls motor torque and speed.

By accurately controlling torque the AC motor will behave very much like a DC motor – without the maintenance.

Closed-Loop Vector Advantages

- Full torque at zero speed
- Selectable rotational or stationary
- Tight speed regulation
- Adaptive tuning for adjustments
- High-speed motor operation during operation
- Direct command of motor torque auto tuning for easy setup

Technical Data

AC Supply (1-Phase Input)	115/230 VAC: 1 to 3 Hp (0.37 to 2.2kW)
AC Supply (3-Phase Input)	230VAC: 1 to 60 Hp (0.37 to 45 kW) 460VAC: 1.0 to 450 Hp (0.75 to 336 kW) 575VAC: 1.0 to 300Hp (0.75 to 224kW)
Enclosure Rating	NEMA 1 Mounting or NEMA 4X (up to 10 Hp)
Control and Speed Range	Volts per Hertz, 20:1 Operating Speed Range Sensorless Vector, 90:1 Operating Speed Range Closed Loop Vector, 1000:1 Operating Speed Range
Operator Interface	LCD 128 x 64 Graphical Display; English Text, Selectable operator screens, Local Control Start/Stop, Forward/Reverse, Speed Increase/Decrease, Programming Operational Parameters, Help Keys
Software Features	Energy Optimization Features, Real Time Clock, Two and three input PID Loop Functions, Preset Speeds, Micro PLC functions, Profile Run and Pulse Velocity follower modes
Communications	Modbus-RTU, built in USB port

Simple to Program and Operate

Navigation keys make the VS1SP and VS1GV easy to use. Familiar up and down keys along with left and right arrows navigate effortlessly through the display and programming functions.

Parameter Save and Copy

If several drives need to be programmed, the keypad can save all the control parameters from one drive and copy those parameters into another drive.

Common Programming Tools

The VS1SP and VS1GV share the same identical operator keypad, field installed options, programming style and operating modes. Baldor has now introduced Windows-based commissioning with Mint® WorkBench, a program common with Baldor's range of servo drives and multi-axis motion controllers.



Unparalleled Ease of Use

Baldor's VS1-series drives are universally acclaimed for their ease of use. A graphical display allows multiple lines of information to be displayed on the screen.

Help Easy at Hand

Every screen displayed on the keypad has help text available to aid the user. Simply press the help key to view the help text.

LED's on Action Keys

There is one LED on each of these keys: REV, JOG, FWD and STOP. These LED's are "ON" whenever the command is active. The active LED assures the operator that the command has been received and accepted.

I/O for Machine Control

On board I/O provides machine control function and allows interfacing to external logic devices such as a PLC or motion controller. A number of preset operating modes are available, including position and speed.



Typical Industries / Applications

- Printing Labeling Processes
- Cut to Length / Indexing
- Packaging Machines
- Pulp and Paper
- Flying Shears
- Textiles
- Petroleum and Chemical
- Extrusion Equipment
- Material Handling
- Metals Industry
- Automotive

Technical Data

Digital Inputs (9)	(8) Assignable, (1) Dedicated Enable Input, 24VDC Control Logic
Digital Outputs (4)	(2) Optically Isolated Outputs, (2) Relay Outputs
Analog Inputs (2)	(1) Differential +/-5VDC, +/-10VDC, 4-20mA and 0-20mA, (1) Single Ended 0-10VDC
Analog Outputs (2)	+/-10VDC or 0 to 20mA
Environmental	-10 to 45 Deg C Ambient, 3300 Feet (1000m) Altitude, 10 to 95% Humidity (non-condensing)
Electrical	115/230/460/575 VAC, 50/60 Hz, 97% Efficiency at full load and frequency
Output Ratings	115% for 1 minute (Normal Duty), 150% for 1 minute (Heavy Duty) Output Current Rating, 0 to 500 Hz Output Frequency, 1 to 16 kHz Carrier
Option Kits	DB Resistors, Keypads and Cables, Isolated Input Card, High Resolution Analog Input Card, Pulse Follower Card, Communication Network Interfaces and Ethernet Server Board

System Solutions

VS1SP and GV Performance Features and Modular Enhancements

Application flexibility is key; providing industry solutions for the market with unique features and application based enhancements are the core design of the VS1SP and VS1GV family. Flexible mounting options allow installation in multiple configurations, you decide. Software setup is a snap using the Mint® WorkBench Software Programming package or the Interchangeable Keypad. From stand alone control to integrated network process line solutions, the VS1SP and VS1GV are flexible enough to meet your application requirements.

More than an Inverter

The VS1SP and VS1GV are more than just standard inverters. Realizing today's applications are more demanding, precise, dynamic and complex, these drives focus on providing creative features and advanced control capabilities.

Some designers choose a standard 'open' PLC platform to perform 'standard' machine functions. Many industries are now looking for the drive platform to accomplish machine functions. The Micro PLC functions and Motion Control package can handle many machine logic tasks internal to the drive. Expanded I/O, communications, and macro functions are available.

Mint® Workbench provides a platform using a common Windows front end to use as a setup tool when commissioning the drives and writing application programming.

Solutions

Baldor is an industry leader in providing complete automation solutions. Our full range of high performance drives, motion controllers, inverter duty motors and rotary servo motors are designed to seamlessly interface with each other.

Experience

Baldor's technical knowledge and application experience enables us to meet a wide range of customer needs. This experience has been gained working with customers from every industry. From design and maintenance to specification engineers, we feed back into our product development this knowledge.

Application notes are available for download on the web at www.baldor.com giving our customers the opportunity to share in our experience.

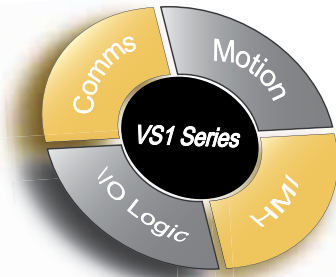

Expansion and Accessory Boards

Baldor offers a wide variety of plug-in expansion boards that allow interface to various controls. One, two or three expansion boards may be mounted into the drive to custom tailor the inputs, outputs, and feedback requirements to the application.



1. Ethernet Server Board - EXBHH001A01

Baldor makes remote monitoring & control easier than ever before with our Ethernet server connection expansion board. This expansion board allows connection with the InterNet, using a standard web browser. Best of all, the control acts as a server, building HTML pages on your desktop computer screen.

2. High Resolution Analog - EXBHH005A01

Provides two additional high resolution inputs and outputs with up to 16 bit resolution:

Outputs are selectable for ± 10 VDC, 0-10 VDC, ± 5 VDC, +10 VDC, 0-20 mA, and 4-20 mA with inverting capability.

3. Isolated Input Board - EXBHH003A01

This board replaces the optical inputs on the main control board with isolated inputs. Screw terminals are provided for easy installation. External voltages from 90-130VAC or dc are supported for the digital inputs.

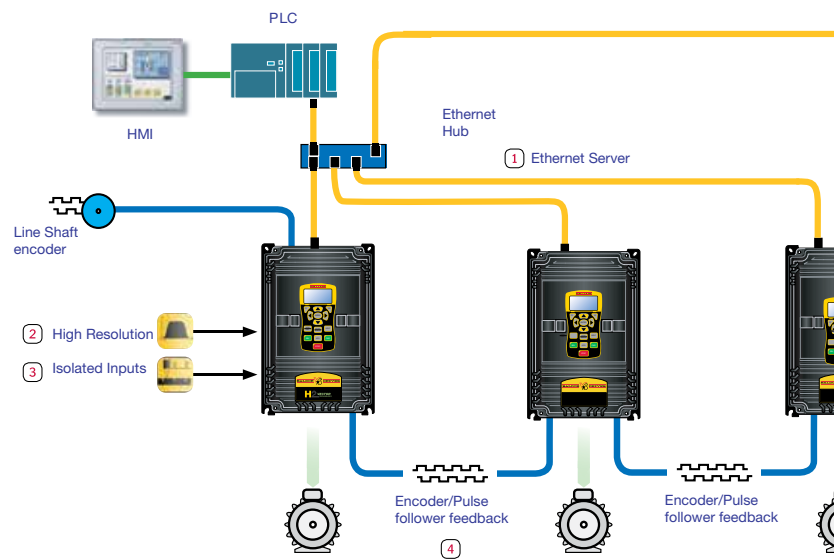

4. Pulse Reference/Pulse Follower - EXBHH007A01

This board is software selectable to create a master pulse reference based on the control's speed/direction command. It can also be selected as an isolated pulse follower. The follower's ratio can be increased or decreased using the keypad.

Communication Interface Options

The ability to communicate is important in industrial automation and even more important in the areas of drives and process control. Baldor VS1SP and VS1GV drives offer a variety of optional plug-in expansion boards that connect directly to several popular PLC and plant automation networks including: DeviceNet, EtherNet/IP, Profibus DP, and LonWorks.

As a standard feature, the drives include a Modbus RTU communications port. If you need your drives to communicate to cells of other machines, or large plant automation networks, the Baldor VS1 drive family can do the talking... and listening too!

5. USB Connection: Every drive comes standard with a built in USB port for communication to a standard computer using the Mint® WorkBench software package.

6. Fieldbus Options: Various fieldbus options are available including DeviceNet, Profibus-DP and LonWorks. Modbus-RTU is available as standard on VS1 and VS1GV drives

EXBHH013A01 DeviceNet/EtherNet/IP/Modbus TCP

EXBHH014A01 Profibus DP

EXBHH015A01 BACnet

EXBHH016A01 LonWorks

EXBHH017A01 MetaSysN2

7. VS1SD Servo Drive: Provides complete servo capability for high performance applications. Moves types such as indexing, cam profiles, software gearboxes and flying shears are supported.

Micro PLC Function

A PLC can add hardware cost and expensive engineering time. With its built in Micro PLC capability the VS1SP and VS1GV can do many simple systems without the need of an external controller. 30 Logical statements, 10 logic variables, 4 timers and 2 variable comparators are available. Actions can be linked to any internal or external event.

Application Based Macro Programming

VS1GV has "macro" capability allowing the drive to be automatically configured to a known state at the press of a button. This macro downloads to the VS1GV using the Mint® WorkBench programming tool. The macro is executed from the keypad or directly from the Mint® WorkBench environment.

Real Time Clock

Want a process to happen at a specified hour of the day? Or know the exact time that a fault or alarm occurred? The real time clock on every VS1SP and VS1GV can announce machine actions such as:

Messages to Screen

- Clean Filter
- Change Filter
- Apply Lubricate
- Service Motor
- Service Drive
- Service Cooling System
- Service Heating System
- RTC Alarm

Qualifiers

- Every Second
- Every Minute
- Hourly
- Daily
- Monthly
- Yearly

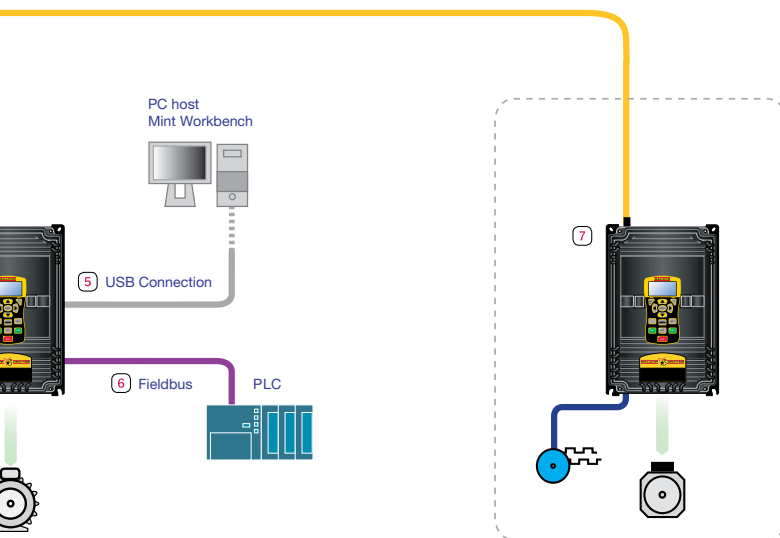

Mint® WorkBench

Application Development Programming Software

Mint® WorkBench is a Windows-based application common across Baldor's range of high performance, servo and motion controllers. WorkBench is an extremely easy to use programming tool useful for commissioning and setup; allowing tuning to the motor in just minutes. The Toolbox allows quick access to features included in WorkBench which is available free with every high performance VS1 Drive.

Features Include:

- Software Oscilloscope to monitor and capture data
- Parameter View/Edit with Upload / Download of drive settings
- Drive Monitoring and diagnostics
- On-Line Help for rapid technical support
- Spy Window to monitor common variables and I/O
- Web updates of product firmware within Mint® WorkBench
- Easy management of firmware files
- Advanced control features such as ActiveX, PLC functions and Composite Reference

Automated Web Update via SupportMe™

If you have web access, you can take advantage of the web updates feature. This will check for firmware updates for your specific drive. The firmware files can be downloaded and installed into a maintained data base on your PC, allowing you to use them as required.

SupportMe™ Technical Support

Baldor's SupportMe™ feature will gather a host of important information from the controller. An email will be generated automatically, offering you the option of attaching programs and additional files. This can be sent directly to your chosen local technical support contact, providing an efficient support mechanism to help you get back up and running.



Quick Access Toolbox

The most common required functions are easily accessed from a tool bar, changing the workspace to suit the job at hand. This toolbox adapts to the type of product being configured and includes:

- Oscilloscope
- Parameter Editor
- Preset Speed/Position Editor
- Digital I/O Monitor/Editor
- PLC Task Monitor/Editor
- Error Log
- Composite Reference Editor



Monitoring Tools

The "SPY" window provides a number of simple monitoring and test features organized into tabs. The default tab shows axis information, other tabs show monitoring information.

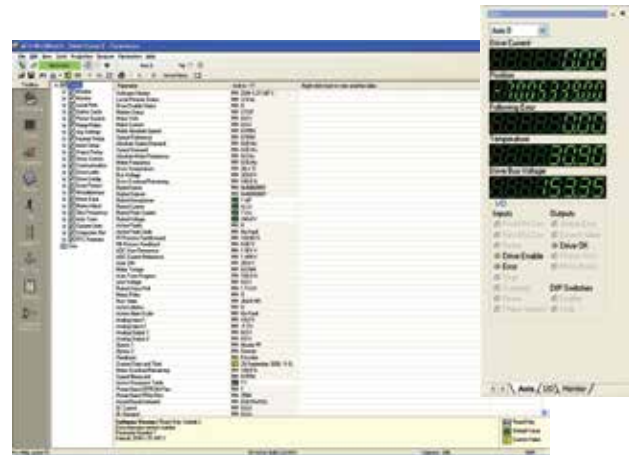

Parameter Editor

This is the main page when Mint® WorkBench opens. The programming block is shown in the left pane with the parameters in the right pane. Parameters can be configured on or off line.

At a glance status information is available to show if a drive value has been changed, is configurable or is at factory default setting.

- Configuration of drive controllers
- View / monitor / edit / save and print parameter files
- Live or offline mode
- Multiple parameter file comparison
- Changed from default indication
- User configured parameter views

Sophisticated Monitoring Tools

Digital I/O Monitor / Editor

With the I/O Tools, Outputs can be edited and monitored. Simply drag and drop to define the condition for a digital output state. Graphical annunciation indicates if the output is active or not.



Oscilloscope

- Multiple channels of display – up to four
- Digital capture of data
- User configured color schemes
- Independent axes scaling
- Save data for future comparison
- Cursor bars measure the value between points
- Intelligent zoom
- Save and overlay multiple views

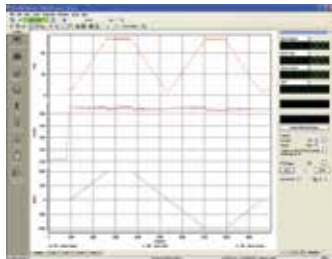

Diagnostic Tools

Context Sensitive Help

A press of the F1 key takes you to the Mint® integrated help, presenting you with information relating to the feature you are trying to use. Help topics are specific to the Toolbox window open, for example pressing F1 with the error log open brings up help topics related to error log tool window.

Error Log

The error log utilizes the real time operating clock to register the exact time of the error or fault in the drive.

For every log entry, a snapshot of a set of variables is taken at the time of the fault. Not only will you know when the fault occurred, but also the operating state of the drive when the fault occurred.



Application Development Tools

PLC Task Editor

- 30 logic rungs to monitor
- Each rung consists of 2 input conditions, 1 logical operation and 1 output action
- Potential for 10 logical (internal) variables
- Simple point and click to show type of logic
- LED indication input/output status



Preset Speed/Position Editor

16 different move profiles without the need for extra interfaces, applications include: Turntables, tool changers, bottle/can fillers, tap and drill, Palletizing and material metering.

Application Macro Programming

A “macro” capability allows the drive to be automatically configured to a known state at the press of a button. The macro is downloaded to the drive using the Mint® WorkBench programming tool and then executed from the keypad or directly from the Mint® WorkBench environment.

This can be useful in applications that require the drive to be reconfigured to a known state on the flow. Applications such as batch processing that require a different drive setup for unique processes are an example.

Composite Reference

- Add, multiply and divide values
- Scale two variables, combine and re-scaled to create one new variable
- Invert values



ActiveX Components

ActiveX® components are provided with Mint® WorkBench as standard and form a powerful toolkit for development PC based visualization, machine control and even OEM production tools. All of the functionality underlying the Mint® WorkBench, is available to the user as ActiveX functions, such as ‘compile and download’, ‘firmware update’, oscilloscope data capture (graphing separate) as well as functions such as I/O operation and much more.

Baldor VS Drives

VS1SD & VS1PM AC Drives

Application Based Performance Drives

Servo Drive and Permanent Magnet Control

- Flexible and versatile drive range
- 115VAC and 230VAC 1-Phase Input
- 230VAC, 460VAC & 575VAC 3-Phase Input
- NEMA 1 or NEMA 4X (Indoor) Enclosure
- Heavy Duty Rating: 150% Overload (VS1PM), 200% (VS1SD)
- Easy to use operator interface
- Flexible I/O configurations
- RS485 Serial Modbus-RTU interface
- Versatile Option cards

The VS1SD provides servo drive control with all of the ease of use and setup you expect in the VS1 product line. For Energy Efficient applications Baldor also offers the VS1PM control, permanent magnet motor operation. The VS1SD and VS1PM use Baldor's Smart Keypad for rapid setup and flexibility. Programming connectivity via USB using Mint® WorkBench simplifies setup. Common to these drives are the option boards and accessories used with the VS1SP and VS1GV drives

VS1SD Servo AC Drive Control

Baldor's VS1SD Servo Drives controls 3-phase AC brushless servomotors. Available in both NEMA 1 and NEMA 4X enclosures, the VS1SD offers resolver feedback as standard. Servo application programming using our free Mint® WorkBench software meets the needs of today's industrial servo market.

Control ratings are available at 115/230 Volts up to 9 Amps, 230 Volts 3-phase to 130 Amps and 460 Volts 3-phase to 124 Amps.



Advanced Features

- 12-bit analog input resolution
- One-touch Autotuning
- Adaptive tuning
- Smart Keypad
- Speed/Torque control
- Resolver and Incremental Encoder feedback
- Simulated Encoder output
- Active-X and ModBus libraries included
- Two expansion board slots for added expansion capabilities
- Same expansion board options as VS1SP and VS1GV

Simple to Program and Operate

Navigation keys make the VS1SD and VS1PM extremely easy to use. Familiar up and down keys along with left and right arrows navigate effortlessly through the display and programming functions.

Parameter Save and Copy

If several drives need to be programmed, the keypad can save all the control parameters from one drive and copy those parameters into another drive.

VS1PM Permanent Magnet Control

Exclusively for use with Baldor Interior Permanent Magnet Motors, the VS1PM offers a high efficiency motor/drive package in a NEMA 1 Enclosure. Both Constant Torque and Variable Loads can benefit from the efficiency gains using permanent magnet control. The VS1PM comes standard with resolver feedback. Control can be automatically tuned to Baldor RPMAC Interior PM Motors.

Ratings are available up to 10 Hp at 230 Volts and 450 Hp at 460 Volts inputs.

Permanent Magnet Control Advantages.

- High bandwidth speed and torque performance
- Power dense motor package increasing response times
- Ultra high operating efficiencies even when lightly loaded
- High Power Factor over full range of loading
- Lower motor temperature rise
- Increased power density and motor torque per rating
- Same expansion board options as VS1SP and VS1GV

The present and future market for drives and motors places a high value on operating efficiency, reliability, flexible control, low running temperature, quiet operation and low cost. Permanent magnet (PM) motors are able to meet the market expectations across a wide range of ratings when couple with the VS1PM AC Drive.

Common Programming Tools

The VS1 performance family of drives (servo, vector, encoderless and inverter) all share the same identical operator keypad, field installed options, programming style and operating modes. The Windows-based Mint® WorkBench is used for commissioning.

Flexible Solutions

Engineering Controls and Application Development

Providing total customer support, the Baldor Drive Center is the focal point for engineering and design, manufacturing adjustable speed drives, printed circuit boards and linear motors. In addition to standard model number product is the ability to integrate these products in customized panels. An example would be a drive in a NEMA enclosure with an input disconnect, fusing and output contactors for bypass control.

Products:

- Low Voltage Drives, AC up to 1500 Hp, DC up to 500 Hp
- Solid State or Reduced Voltage Starters
- Stand Alone Panels or Multiple Drive Cabinets
- MCC Control Panels
- Integrated Motion Control Products
- Shared DC Bus Systems
- Custom Testing, matched motor and drive performance testing and witness certification

Matched Performance

Baldor Electric not only provides a complete engineered control assembly, but can also take responsibility for the entire package from the control to the motor through to the drive machine mechanical gearing. Performance testing ensures a reliable and efficient startup of the completed system.

Modified Standard Drives

In addition to custom control cabinets, Baldor Electric designs, manufactures and supports modified configured drives. These are custom control panels but in standard configurations. An example is the VS1PFB, a VS1PF AC drive for the Pump and Fan industry, package in a stock bypass cabinet configuration

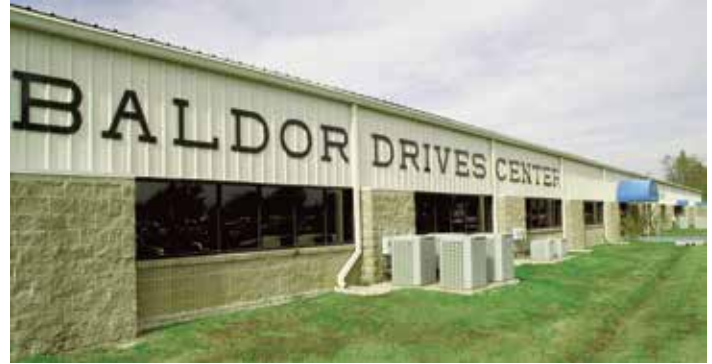

Baldor Drives Center

Size: 150,000 Square Feet

Employees: 120

UL508, ISO 9000 Certified Facility

- Adjustable Speed Drives
- 1/3 to 1500 Hp Inverter, Vector and Servo
- Soft Starts & Dynamic Brakes
- Custom Panels NEMA 1, 3R, 4X, 12
- Circuit Boards
- R & D Laboratory

Experience Sales Support

Specification and requirement review is conducted by our experienced team to ensure the best possible design matched to the application. Our engineering group is familiar with motor control applications, providing quick quotation turn around and drawings for approval. Startup and commissioning support are available along with parts and troubleshooting expertise.

Dedicated engineering group

- Drawings submitted in one week for approval
- Familiarity with motor control applications
- Experience with UL508, NEC and NEMA standards
- Expertise in multiple brands of motor branch circuit power components
- Experience with a variety of motor control circuits, schemes, methods and devices

Contact your nearest Baldor Sales Office at these World Wide Locations, or visit www.baldor.com

UNITED STATES**ARIZONA**

PHOENIX
4211 S 43RD PLACE
PHOENIX, AZ 85040
PHONE: 602-470-0407
FAX: 602-470-0464

ARKANSAS

CLARKSVILLE
706 WEST MAIN STREET
CLARKSVILLE, AR 72830
PHONE: 479-754-9108
FAX: 479-754-9205

CALIFORNIA

LOS ANGELES
6480 FLOTILLA STREET
COMMERCE, CA 90040
PHONE: 323-724-6771
FAX: 323-721-5859

HAYWARD

21056 FORBES STREET
HAYWARD, CA 94545
PHONE: 510-785-9900
FAX: 510-785-9910

COLORADO

DENVER
3855 FOREST STREET
DENVER, CO 80207
PHONE: 303-623-0127
FAX: 303-595-3772

CONNECTICUT

WALLINGFORD
65 SOUTH TURNPIKE ROAD
WALLINGFORD, CT 06492
PHONE: 203-269-1354
FAX: 203-269-5485

FLORIDA

**TAMPA/PUERTO RICO/
VIRGIN ISLANDS**
3906 EAST 11TH AVENUE
TAMPA, FL 33605
PHONE: 813-248-5078
FAX: 813-241-9514

GEORGIA

ATLANTA
62 TECHNOLOGY DRIVE
ALPHARETTA, GA 30005
PHONE: 770-772-7000
FAX: 770-772-7200

ILLINOIS

CHICAGO
340 REMINGTON BLVD.
BOLINGBROOK, IL 60440
PHONE: 630-296-1400
FAX: 630-226-9420

INDIANA

INDIANAPOLIS
5525 W. MINNESOTA STREET
INDIANAPOLIS, IN 46241
PHONE: 317-246-5100
FAX: 317-246-5110

IOWA

DES MOINES
1943 HULL AVENUE
DES MOINES, IA 50313
PHONE: 515-263-6929
FAX: 515-263-6515

MARYLAND

BALTIMORE
6660 SANTA BARBARA RD.
SUITES 22-24
ELKRIDGE, MD 21075
PHONE: 410-579-2135
FAX: 410-579-2677

MASSACHUSETTS

BOSTON
6 PULLMAN STREET
WORCESTER, MA 01606
PHONE: 508-854-0708
FAX: 508-854-0291

MICHIGAN

DETROIT
5993 PROGRESS DRIVE
STERLING HEIGHTS, MI 48312
PHONE: 586-978-9800
FAX: 586-978-9969

MINNESOTA

MINNEAPOLIS
13098 GEORGE WEBER DR,
SUITE 400
ROGERS, MN 55374
PHONE: 763-428-3633
FAX: 763-428-4551

MISSOURI

ST LOUIS
13678 LAKEFRONT DRIVE
EARTH CITY, MO 63045
PHONE: 314-373-3032
FAX: 314-373-3038

KANSAS CITY

1501 BEDFORD AVENUE
NORTH KANSAS CITY, MO 64116
PHONE: 816-587-0272
FAX: 816-587-3735

NEW YORK

AUBURN
ONE ELLIS DRIVE
AUBURN, NY 13021
PHONE: 315-255-3403
FAX: 315-253-9923

NORTH CAROLINA

GREENSBORO
1220 ROTHERWOOD ROAD
GREENSBORO, NC 27406
PHONE: 336-272-6104
FAX: 336-273-6628

OHIO

CINCINNATI
2929 CRESCENTVILLE ROAD
WEST CHESTER, OH 45069
PHONE: 513-771-2600
FAX: 513-772-2219

CLEVELAND

8929 FREEWAY DRIVE
MACEDONIA, OH 44056
PHONE: 330-468-4777
FAX: 330-468-4778

OKLAHOMA

TULSA
5555 E. 71ST ST., SUITE 9100
TULSA, OK 74136
PHONE: 918-366-9320
FAX: 918-366-9338

OREGON

PORTLAND
12651 SE CAPPS ROAD
CLACKAMAS, OR 97015
PHONE: 503-691-9010
FAX: 503-691-9012

PENNSYLVANIA

PHILADELPHIA
1035 THOMAS BUSCH
MEMORIAL HIGHWAY
PENNSAUKEN, NJ 08110
PHONE: 856-661-1442
FAX: 856-663-6363

PITTSBURGH

159 PROMINENCE DRIVE
NEW KENSINGTON, PA 15068
PHONE: 724-889-0092
FAX: 724-889-0094

TENNESSEE

MEMPHIS
4000 WINCHESTER ROAD
MEMPHIS, TN 38118
PHONE: 901-365-2020
FAX: 901-365-3914

TEXAS

DALLAS
2920 114TH STREET SUITE 100
GRAND PRAIRIE, TX 75050
PHONE: 214-634-7271
FAX: 214-634-8874

HOUSTON

10355 W. LITTLE YORK ROAD
SUITE 300
HOUSTON, TX 77041
PHONE: 281-977-6500
FAX: 281-977-6510

UTAH

SALT LAKE CITY
2230 SOUTH MAIN STREET
SALT LAKE CITY, UT 84115
PHONE: 801-832-0127
FAX: 801-832-8911

WISCONSIN

MILWAUKEE
1960 SOUTH CALHOUN ROAD
NEW BERLIN, WI 53151
PHONE: 262-784-5940
FAX: 262-784-1215

INTERNATIONAL SALES

FORT SMITH, AR
P.O. BOX 2400
FORT SMITH, AR 72902
PHONE: 479-646-4711
FAX: 479-648-5895

CANADA

EDMONTON, ALBERTA
4053-92 STREET
EDMONTON, ALBERTA T6E 6R8
PHONE: 780-434-4900
FAX: 780-438-2600

TORONTO

OAKVILLE, ONTARIO
2750 COVENTRY ROAD
OAKVILLE, ONTARIO L6H 6R1
PHONE: 905-829-3301
FAX: 905-829-3302

MONTREAL, QUEBEC

5155 J-ARMAND BOMBARDIER
SAINT-HUBERT, QUÉBEC
CANADA J3Z 1G4
PHONE: 514-933-2711
FAX: 514-933-8639

VANCOUVER,

BRITISH COLUMBIA
1538 KEBET WAY
PORT COQUITLAM,
BRITISH COLUMBIA V3C 5M5
PHONE 604-421-2822
FAX: 604-421-3113

WINNIPEG, MANITOBA

54 PRINCESS STREET
WINNIPEG, MANITOBA R3B 1K2
PHONE: 204-942-5205
FAX: 204-956-4251

MEXICO

LEON, GUANAJUATO
KM. 2.0 BLVD. AEROPUERTO
LEON, GUANAJUATO, CP37545
MEXICO
PHONE: +52 477 761 2030
FAX: +52 477 761 2010

Baldor Electric Company

P.O. Box 2400

Fort Smith, AR 72902-2400 U.S.A.

Ph (479) 646-4711 • Fax (479) 648-5792

International Fax (479) 648-5895

www.baldor.com