

BALDOR® • *RELIANCE*

Product Information Packet

GM3301

G.M. F20UF 230/460 173 RPM 10:1

Product Detail							
Revision:	H	Status:	PRD/A	Change #:		Proprietary:	No
Type:		Prod Type:		Elec. Spec:		CD Diagram:	
Enclosure	TEFC	Mfg Plant:		Mech Spec:		Layout:	33E282-0673K4
Frame:	JH	Mounting:		Poles:		Created Date:	
Base:		Rotation:	R	Insulation:	B	Eff. Date:	04-28-2008
Leads:	9#18		Y			Replaced By:	

Nameplate NP1220A07

CAT.NO.	GM3301						
SER.NO	DATE CODE						
SPEC.	33E282-0673K4						
HP	.45 TE						
VOLTS	208-230/460						
AMP	2.1-2.38/1.20						
HZ	60	PH					3
AMB.	40C	DUTY					CONT
CAP		CODE					-
SER.F.	1.00	CLASS					B
R.P.M.	174						
TORQ/IN LB	135						
RATIO	10:1						
APRV-CSA				APRV-UL			

Parts List			
Product ID	Description	Quantity	List Price
SR001268	SR 33E282-0673K4	1.000	205.00
33E282-0673	.5HP,1725RPM,3PH,60HZ,42CZ,3320M,TEFC,F1	1.000	
HA6032A04	ADAPTER, MACH F/BOEHM MACH'D. FOR SEAL	1.000	43.00
10XN2520A16	1/4-20 X 1 HEX HEAD CAP SCR, ZINC PLATED	4.000	2.00
HW1001A25	LOCKWASHER 1/4, ZINC PLT .493 OD, .255 I	4.000	2.00
HW4600B91	SEAL, TCM #06132TB .625X1.375X.252	1.000	14.00
RM1057	RUBBER SQUARE RING 1.424 I.D.	1.000	2.00
WM0055A16	WORM,JH 10.0 INP PINNED ON (918 GEOME	1.000	89.00
MJ5019A01	ADHESIVE LOCTITE #680 WAS BAD4525	0.010	276.00
HW3081C06	3/32 X 5/8 GROOVE PIN TYPE A,THRU HARDEN	1.000	2.00
HG0039A04G	HSG,JK EX CLOSED W/ GRAY POWDER COAT	1.000	62.00
19XN1032A12	SCREW, HEX WASHER HEAD, #10-32 X .750	4.000	2.00
HA1194B01	BLADDER,CJK EXPANSION	1.000	15.00
15XM0632A06	SCREW, 6-32X .375, THREAD FORMING	3.000	2.00
HA4021A05	1/16 NPSF-HX SOC PIPE PLUG TAPER DRY SEA	1.000	2.00
HW5109A10	WASHER, WAVE SPRING FOR 47MM BORE SMALLE	1.000	2.00
BS0114A01G	BS,JH OP 6204STD OPEN W/ GRAY POWDER COA	1.000	34.00
BG6204C03	BEARING 0.787 X 1.850 X .551 SHIELD	1.000	30.00
HW5002A57	WALDES N5002-187 BEVELED 1.850	1.000	3.00
15XM0832A08	SCREW, 8-32X .500, THREAD FORMING	4.000	2.00
RM1020A21	O-RING,3.240 I.D. X .052 BUNA (PGS) BGA4	1.000	2.00
HW4600D39	SEAL, .750 X 1.250 X .250 SINGLE	1.000	2.00
HW2501D10	KEY, 3/16 SQ X 1.000	1.000	2.00
BMH4712	KEY LOCKING RING 3/4"	1.000	2.00

Parts List (continued)			
Product ID	Description	Quantity	List Price
MJ1000B02	KLUBERSYNTH GH6-460 GEAR OIL	0.030	215.00
MG3000G01	EPOXY POWDER, GREY CHARCOAL	0.010	37.00
MG1025G05	PAINT DRK MET.GRAY,W/ACTIVATOR	0.010	182.00
NP1220A07	NP,AC STD AD NONE V CSA UL GEAR MOTOR	1.000	
CPA1001	PACKING GROUP OVERSIZED SINGLE	1.000	19.00
LB1125A01SP	STOCK MTR CARTON LABEL LASER PRINTER	1.000	3.00

33E282-0673K4

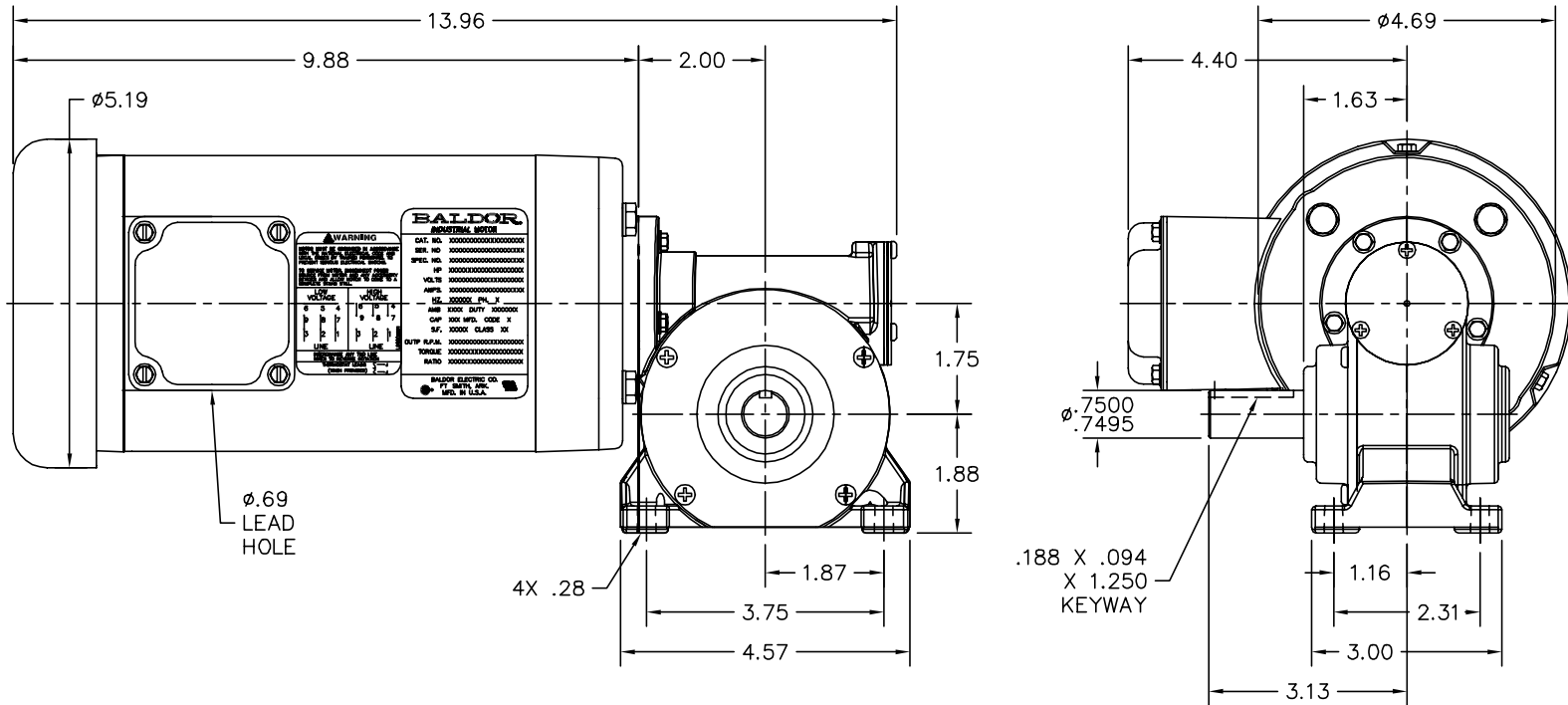

CUSTOMER IS RESPONSIBLE FOR DETERMINING THAT MOTOR PERFORMANCE IS SUITABLE IN THE APPLICATION.

REV. DESC: UPDATE LAYOUT			
REV. LTR: A	VERSION: 01	TDR: 000000425648	
33E282-0673K4	FILE: \CKA\00024\625	REVISED: 10:10:23 03/20/2007	
	MTL: -	BY: CKMARD0	

BALDOR ELECTRIC Co.

LY,33DC JH RSB TEFC GP NONE 918 GEARING

33E282-0673K4